

Spearhead

TWIGA Reach Mower 320/420



Edition 1.3 – April 2014
Part No. 8999059

HANDBOOK

Spearhead TWIGA 320/420

CE Declaration of Conformity, Conforming to EU Machinery Directive 2006/42/EC

We, Spearhead Machinery Ltd, Green View, Salford Priors, Evesham,
Worcestershire, WR11 8SW hereby declare that:

Product

Product Code.....

Serial No.....

Type.....

Manufactured by: Alamo Manufacturing Services (UK) Limited, Station Road,
Salford Priors, Evesham, Worcestershire, WR11 8SW

Complies with the required provisions of the Machinery Directive 2006/42/EC. The
Machinery Directive is supported by the following harmonized standards:

- BS EN ISO 14121-1 (2007) Safety of Machinery – Risk Assessment, Part 1: Principles Part 2: Practical Guide and Examples of Methods.
- BS EN ISO 12100-1 (2010) Safety of Machinery – Part 1: Basic Terminology and Methodology Part 2: Technical Principles.
- BS EN 349 (1993) + A1 (2008) Safety of Machinery – Minimum Distances to avoid the Entrapment of Human Body Parts.
- BS EN 953 (1998) Safety of Machinery – Guards General Requirements for the Design and Construction of Fixed and Movable Guards.
- BS EN 982 (1996) + A1 (2008) Safety Requirements for Fluid Power Systems and their Components. Hydraulics.

The EC Declaration only applies if the machine stated above is used in accordance
with the operating instructions.

Signed



(On behalf of Spearhead Machinery Ltd)

Status

General Manager

Date

01/04/2014

IMPORTANT VERIFICATION OF WARRANTY REGISTRATION



DEALER WARRANTY INFORMATION & REGISTRATION VERIFICATION

It is imperative that the selling dealer registers this machine with Spearhead Machinery Limited before delivery to the end user – failure to do so may affect the validity of the machine warranty.

To register machines go to the Spearhead Machinery Limited web site at www.spearheadmachinery.com, log onto 'Dealer Inside' and select the 'Machine Registration button' which can be found in the Service Section of the site. Confirm to the customer that the machine has been registered in the section below.

Should you experience any problems registering a machine in this manner please contact the Spearhead Service Department on 01789 491867.

Registration Verification

Dealer Name:
Dealer Address:
Customer Name:
Date of Warranty Registration:/...../..... Dealer Signature:

NOTE TO CUSTOMER / OWNER

Please ensure that the above section has been completed and signed by the selling dealer to verify that your machine has been registered with Spearhead Machinery Limited.

IMPORTANT: During the initial 'bedding in' period of a new machine it is the customer's responsibility to regularly inspect all nuts, bolts and hose connections for tightness and re-tighten if required. New hydraulic connections occasionally weep small amounts of oil as the seals and joints settle in – where this occurs it can be cured by re-tightening the connection – *refer to torque settings chart below*. The tasks stated above should be performed on an hourly basis during the first day of work and at least daily thereafter as part of the machines general maintenance procedure.

Spearhead TWIGA 320/420

CAUTION: DO NOT OVER TORQUE HYDRAULIC FITTINGS AND HOSES

TORQUE SETTINGS FOR HYDRAULIC FITTINGS

HYDRAULIC HOSE ENDS			PORT ADAPTORS WITH BONDED SEALS		
BSP	Setting	Metric	BSP	Setting	Metric
1/4"	18 Nm	19 mm	1/4"	34 Nm	19 mm
3/8"	31 Nm	22 mm	3/8"	47 Nm	22 mm
1/2"	49 Nm	27 mm	1/2"	102 Nm	27 mm
5/8"	60 Nm	30 mm	5/8"	122 Nm	30 mm
3/4"	80 Nm	32 mm	3/4"	149 Nm	32 mm
1"	125 Nm	41 mm	1"	203 Nm	41 mm
1.1/4"	190 Nm	50 mm	1.1/4"	305 Nm	50 mm
1.1/2"	250 Nm	55 mm	1.1/2"	305 Nm	55 mm
2"	420 Nm	70 mm	2"	400 Nm	70 mm

WARRANTY POLICY

WARRANTY REGISTRATION

All machines must be registered, by the selling dealer with Spearhead Machinery Ltd, before delivery to the end user. On receipt of the goods it is the buyer's responsibility to check that the Verification of Warranty Registration in the Operator's Manual has been completed by the selling dealer.

1. LIMITED WARRANTIES

1.01. All machines supplied by Spearhead Machinery Limited are warranted to be free from defects in material and workmanship from the date of sale to the original purchaser for a period of 12 months, unless a different period is specified.

1.02. All spare parts supplied by Spearhead Machinery Limited are warranted to be free from defects in material and workmanship from the date of sale to the original purchaser for a period of 6 months.

1.03. The manufacturer will replace or repair for the purchaser any part or parts found, upon examination at its factory, to be defective under normal use and service due to defects in material or workmanship. Returned parts must be complete and unexamined.

1.04. This warranty does not apply to any part of the goods, which has been subjected to improper or abnormal use, negligence, alteration, modification, fitment of non-genuine parts, accident damage, or damage resulting from contact with overhead power lines, damage caused by foreign objects (e.g. stones, iron, material other than vegetation), failure due to lack of maintenance, use of incorrect oil or lubricants, contamination of the oil, or which has served its normal life. This warranty does not apply to any expendable items such as blades, flails, bushes, belts, flap kits, skids, shields, guards, wear pads or pneumatic tyres.

1.05. Temporary repairs and consequential loss - i.e. oil, downtime and associated parts are specifically excluded from the warranty.

Spearhead TWIGA 320/420

- 1.06. Warranty on hoses is limited to 12 months and does not include hoses which have suffered external damage. Only complete hoses may be returned under warranty, any which have been cut or repaired will be rejected.
- 1.07. Machines must be repaired immediately a problem arises. Continued use of the machine after a problem has occurred can result in further component failures, for which Spearhead Machinery Ltd cannot be held liable, and may have safety implications.
- 1.08. Except as provided herein, no employee, agent, dealer or other person is authorised to give any warranties of any nature on behalf of Spearhead Machinery Ltd.
- 1.09. For machine warranty periods in excess of 12 months the following additional exclusions shall apply:
- 1.09.1. Hoses, external seals, exposed pipes and hydraulic tank breathers.
 - 1.09.2. Filters
 - 1.09.3. Rubber mountings
 - 1.09.4. External electric wiring.
 - 1.09.5. Labour and mileage costs.
- 1.10. All service work, particularly filter changes, must be carried out in accordance with the manufacturer's service schedule. Failure to comply will invalidate the warranty. In the event of a claim, proof of the service work being carried out may be required.

NB Warranty cover will be invalid if any non-genuine parts have been fitted or used. Use of non-genuine parts may seriously affect the machine's performance and safety. Spearhead Machinery Ltd cannot be held responsible for any failures or safety implications that arise due to the use of non-genuine parts.

2. REMEDIES AND PROCEDURES

- 2.01. The warranty is not effective unless the Selling Dealer registers the machine, via the Spearhead Machinery web site and confirms the registration to the purchaser by completing the confirmation form in the operator's manual.
- 2.02. Any fault must be reported to an authorised Spearhead Machinery dealer as soon as it occurs. Continued use of a machine, after a fault has occurred, can result in further component failure for which Spearhead Machinery Ltd cannot be held liable.
- 2.03. Repairs should be undertaken within two days of the failure. Claims submitted for repairs undertaken more than 2 weeks after a failure has occurred, or 2 days after the parts were supplied will be rejected, unless the delay has been authorised by Spearhead Machinery Ltd.
- 2.04. All claims must be submitted, by an authorised Spearhead Machinery Service Dealer, within 30 days of the date of repair.

Spearhead TWIGA 320/420

2.05. Following examination of the claim and parts the manufacturer will pay, at their discretion, for any valid claim the cost of any parts and an appropriate labour allowance if applicable.

2.06. The submission of a claim is not a guarantee of payment.

2.07. Any decision reached by Spearhead Machinery Ltd is final.

3. LIMITATION OF LIABILITY

3.01. The manufacturer disclaims any express (except as set forth herein) and implied warranties with respect to the goods including, but not limited to, merchantability and fitness for a particular purpose.

3.02. The manufacturer makes no warranty as to the design, capability, capacity or suitability for use of the goods.

3.03. Except as provided herein, the manufacturer shall have no liability or responsibility to the purchaser or any other person or entity with respect to any liability, loss, or damage caused or alleged to be caused directly or indirectly by the goods including, but not limited to, any indirect, special, consequential, or incidental damages resulting from the use or operation of the goods or any breach of this warranty. Notwithstanding the above limitations and warranties, the manufacturer's liability hereunder for damages incurred by the purchaser or others shall not exceed the price of the goods.

3.04. No action arising out of any claimed breach of this warranty or transactions under this warranty may be brought more than one (1) year after the cause of the action has occurred.

4. MISCELLANEOUS

4.01. The manufacturer may waive compliance with any of the terms of this limited warranty, but no waiver of any terms shall be deemed to be a waiver of any other term.

4.02. If any provision of this limited warranty shall violate any applicable law and is held to be unenforceable, then the invalidity of such provision shall not invalidate any other provisions herein.

4.03. Applicable law may provide rights and benefits to the purchaser in addition to those provided herein.

Spearhead TWIGA 320/420

Contents

General Information

EC Declaration of conformity.....	1
Warranty.....	2
Introduction.....	8
Specification.....	9

Safety

Safety Recommendations.....	10
Overhead Power Lines.....	12
Safety Decal.....	14
Warning Signs.....	14
Roadwork Guidelines.....	14
Training.....	15
Tractor Requirements.....	15

Installing your Machine

Attaching To The Tractor.....	16
Running Up Your Machine.....	20
Removing From The Tractor.....	20
Cable Controls.....	21
MINIPILOT Controls.....	21
Operational Warnings.....	25
Operation.....	26
Cutter Bar.....	27
Head Float.....	28
Arm Float.....	29
Oil Cooler.....	30

Servicing & Maintenance

Lubrication Chart.....	31
Torque Settings.....	32
Hydraulic Hoses.....	33
Oil Supply.....	34
Filtration Maintenance.....	34
Pins & Bushes.....	35
Regular Service Chart.....	36
Pump & Motor Failure.....	36

Spearhead TWIGA 320/420

Introduction

The TWIGA is a very robust high capacity reach mower that is easy to operate and maintain. To ensure trouble-free operation this manual should be carefully studied.

The term Left and Right hand applies to the machine when coupled to the tractor and viewed from the rear, this also applies to the tractor.

Important Note

The information contained in this manual is correct at the time of publication. However, in the course of constant development, changes in specification are inevitable. Should you find the information given in this book different to the Machine it relates to please contact the "After Sales Department" for advice.

Please ensure that this manual is handed to the operator before using the machine for the first time. The operator must fully understand the contents of this manual before using this machine.

(If the machine is resold the Manual must be given to the new owner.)

Spearhead TWIGA 320/420

Specification

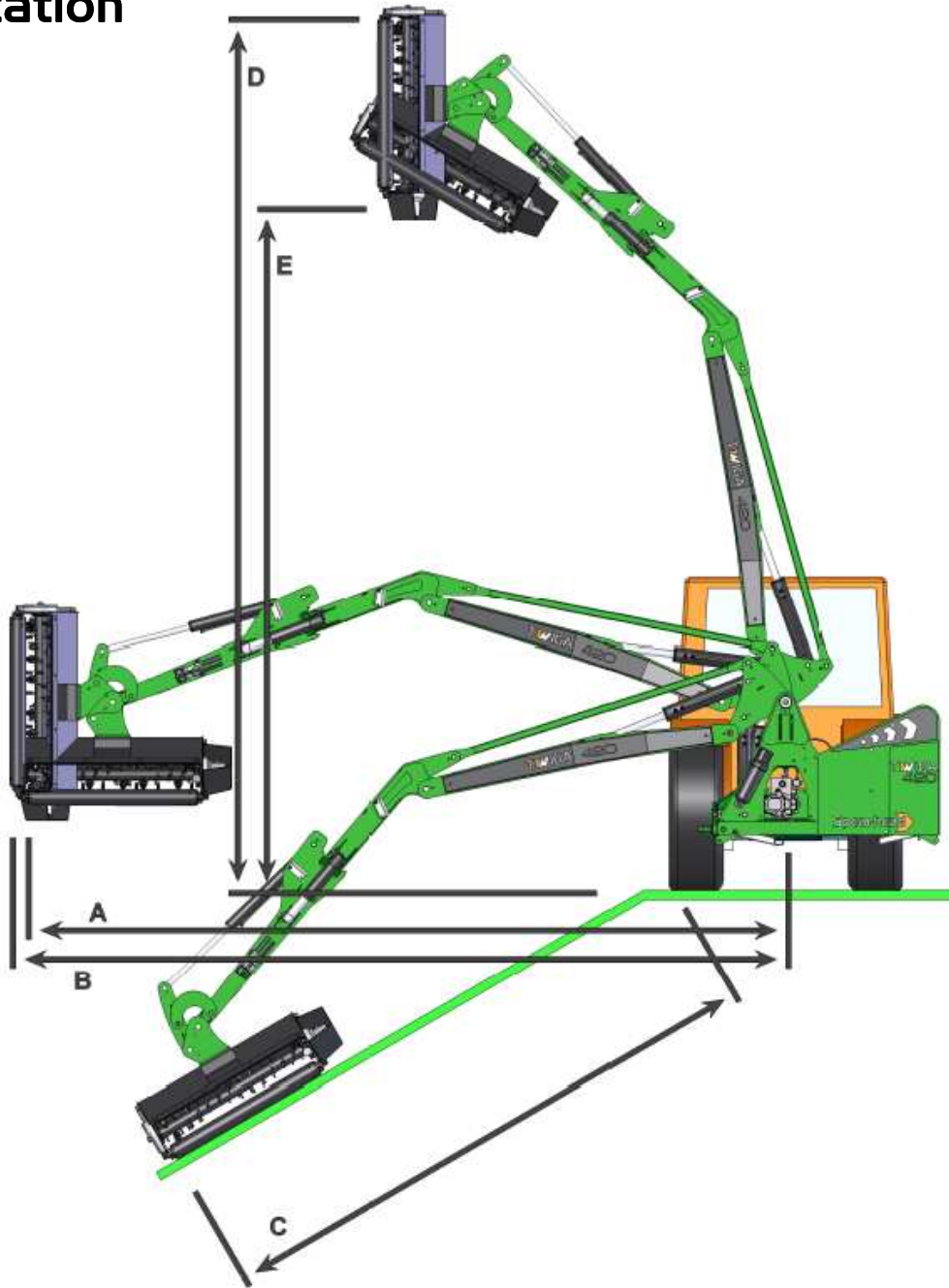

	320	420
Weight inc. Oil (Kg)	1350	1370
Weight of head (Kg)	130	130
Tractor horse power	25	40
Min. tractor weight (Kg)	1300	2000
Oil tank capacity (ltr)	60	60
Reach A (m)	3.2	4.2
Reach B (m)	3.3	4.3
Reach C (m)	2.1	3.1
Reach D (m)	3.8	4.8
Reach E (m)	2.8	3.8

Safety Recommendations

Beware of the following Potential Dangers associated with the use of this machine:

- Becoming trapped when hitching or unhitching
- Tractor overbalancing when arm is extended
- Electrocution due to hitting overhead power lines
- Getting caught on rotating power take off (PTO)
- Being hit or caught by any moving part, e.g. belts, pulleys, arms, cutting head
- Being hit by flying debris or machine parts due to machine damage
- Machine overbalancing when not in use
- Injection of high pressure oil from damaged couplings or hydraulic hoses
- Accidents due to collision with other machines, or debris left on road

Always

- Ensure the operator has read this handbook and has been trained to use the machine.
- Ensure all cab safety guards are in place and all tractor windows closed.
- Before leaving the tractor cab always ensure that the flail head is firmly on the ground, no weight is on the machine's hydraulics and the rotor has stopped spinning.
- Check that all guards are properly fitted and there are no damaged or loose parts. Particular attention should be given to the flails to ensure they are not damaged, cracked or missing.
- Inspect work area for wire, steel posts, large stones and other dangerous materials and remove before starting work.
- Beware of the danger of overhead power cables. The operator must be aware of the maximum height and reach of the machine when working under power cables. For more information contact the Health and Safety Executive or your local power company.
- Ensure that all warning labels are always visible and that they are not damaged, defaced or missing.
- Lower the head to the ground when parking up
- Fit locking pins to slew and height before transport and before unhitching when applicable.
- Wear ear defenders if operating without a quiet cab or with the cab windows open.
- Ensure tractor guards are fitted correctly and are undamaged
- Work at a safe speed, taking into account terrain, passing vehicles and obstacles
- Ensure that the tractor meets the minimum weight recommendations of the machine manufacturer and that ballast is used if necessary
- Check that machine fittings and couplings are in good condition
- Follow the manufacturer's instructions for attachment and removal of machine from the tractor are warning signs to alert others to the type of machine working in the vicinity. Signs should be placed at both ends of the

Spearhead TWIGA 320/420

work site and should be in accordance with Department of Transport recommendations.

- Ensure flails are of the type recommended by the manufacturer, are securely fitted and are undamaged.
- Ensure hydraulic pipes are correctly routed to avoid damage from chafing, stretching, pinching or kinking.
- Disengage the machine, stop the engine and remove the key before leaving the tractor cab for any reason.
- Clean up any debris left at the work site.
- Ensure that when you remove the machine from the tractor it is secured in a safe position using the stands provided.

NEVER

- Never operate the machine with other people present, as it is possible for debris, including stones, to be discharged from the front and rear of the flail head.
- Never operate the machine until you have read and understood the relevant Handbook and are familiar with the controls.
- Never use a machine that is poorly maintained or has guards that are damaged or missing
- Never allow an inexperienced person to operate the machine without supervision.
- Never use or fit a machine onto a tractor if it doesn't meet the manufacturer's specification.
- Never use a machine if the hydraulic system shows signs of damage.
- Never attempt to detect a hydraulic leak with your hand, use a piece of card.
- Never allow children to play on or around the machine at any time.
- Never attempt any maintenance or adjustment without first disengaging the PTO, lowering the head to the ground, stopping the tractor engine and applying the tractor parking brake.
- Never leave the cab without removing the ignition key.
- Never operate the tractor or any controls from any position other than from the driving seat.
- Never stop the engine with the PTO engaged.
- Never operate with flails missing.
- Never operate PTO **above** recommended speed for your machine, 540 R.P.M. / 1000 R.P.M. flail head, 150 R.P.M. cutter-bar.
- Never operate with wire around the rotor. Stop immediately.
- Never use the head at an angle, which may throw debris towards the cab.
- Never attempt to use the machine for any purpose other than that it was designed for.
- Never transport with the PTO engaged
- Never enter the working area of the machine (risk of injury!)
- Never transport with the controls live, always turn off electrical isolator switch (red) and disconnect supply.

Spearhead TWIGA 320/420

Overhead Power Lines

It cannot be stressed enough the dangers involved when working in the vicinity of Overhead Power Lines (OHPLs). Some of our machines are capable of reach in excess of 8 metres (26'); they have the potential to well exceed, by possibly 3 metres (9' 9"), the lowest legal minimum height of 5.2 metres from the ground for 11,000 and 33,000 volt power lines. Remember electrocution can occur without actually coming into contact with a power line as electricity can 'flashover' when machinery gets close to it.



WARNING: All operators must read the following information and be aware of the risks and dangers involved when working in the vicinity of Overhead Power Lines (OHPLs).

Wherever possible the safest option is always to avoid working in areas close to OHPLs. Where unavoidable, all operators must perform a risk assessment and implement a safe procedure and system of work – see *following page for details*. All operators should perform a risk assessment before operating the machine within 10m horizontal distance of any OHPLs.

Minimum Heights for Overhead Power Lines

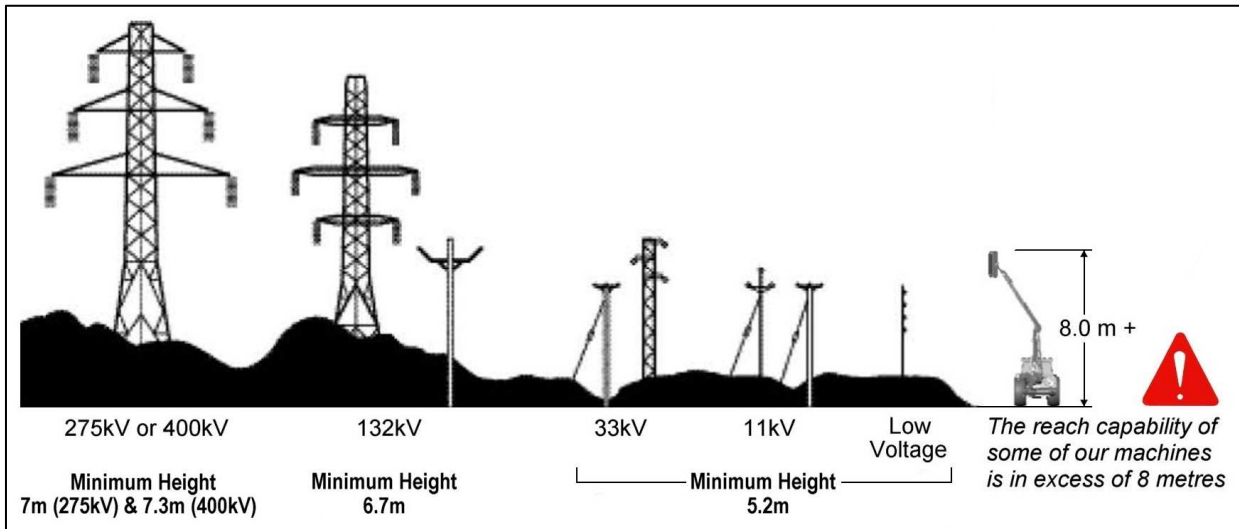

Absolute Minimum Exclusion Zones for Specific Overhead Power Lines

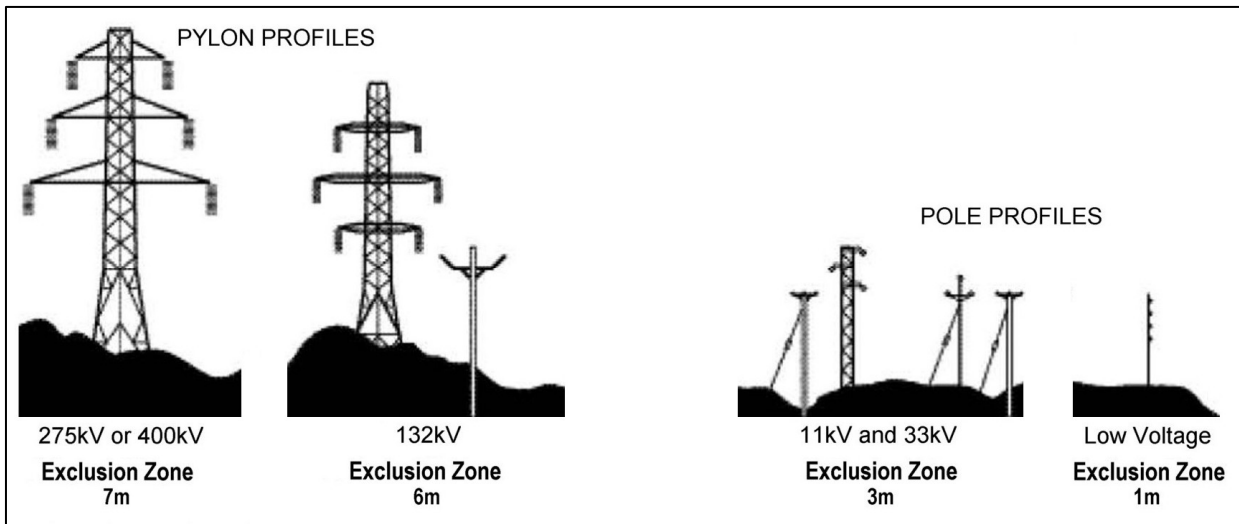

Spearhead TWIGA 320/420

Definitions of Exclusion Zones

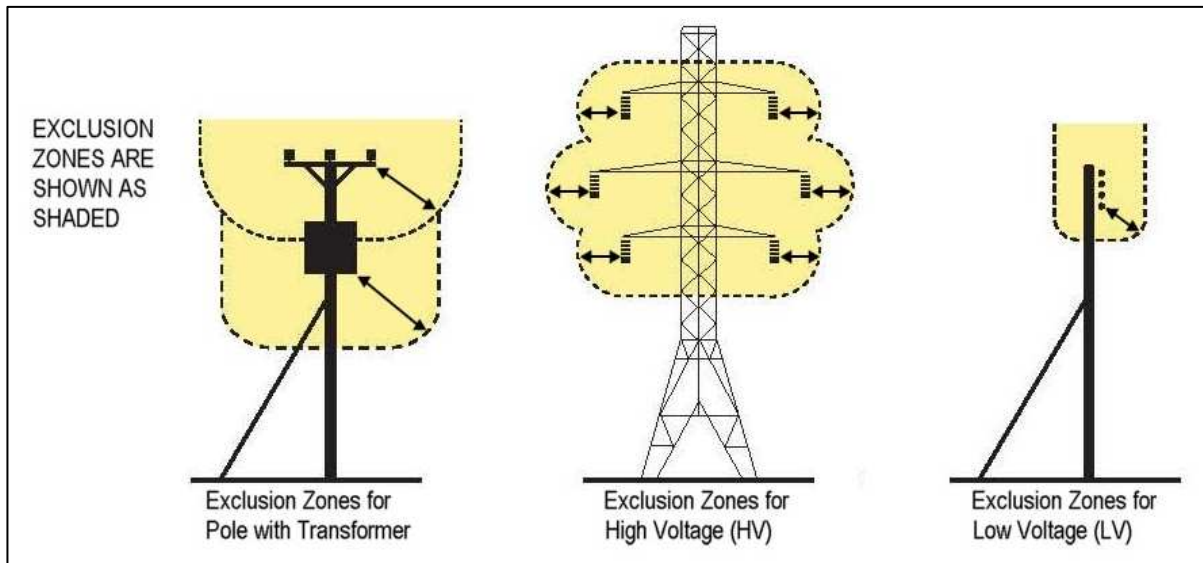

Risk Assessment

Before starting to work near OHPLs you should always assess the risks. The following points should be observed;

Know the risks of contacting OHPLs and the risk of flashover.

Find out the maximum height and maximum vertical reach of your machine.

Find out the location and route of all Power Lines within the work area.

Find out the operating voltage of all Power Lines within the work area.

Contact the local Distribution Network Operator (DNO) who will be able to advise you on the operating voltage, safe minimum clearance distance for working and additional precautions required.

Never attempt operate the machine in an exclusion zones.

Always work with extreme caution and plan your work ahead to avoid high risk areas.

If doubt exists do not work in the area – never risk the safety of yourself or others.

Emergency Action for Accidents Involving Electricity

- Never touch an overhead line - even if it has been brought down by machinery, or has fallen. Never assume lines are dead.
- When a machine is in contact with an overhead line, electrocution is possible if anyone touches both the machine and the ground. Stay in the machine and lower any raised parts in contact or drive the machine out of the lines if you can.
- If you need to get out to summon help or because of fire, jump out as far as you can without touching any wires or the machine - keep upright and away.
- Get the electricity company to disconnect the supply. Even if the line appears dead, do not touch it - automatic switching may reconnect the power.

Further information and leaflets on this and other agricultural safety subjects are available on the 'Health & Safety Executive' website at the following address:

www.hse.gov.uk/pubns/agindex.htm

Spearhead TWIGA 320/420



Safety Decal

Warning

Check all bolts are tight every 8 hours.

Warning

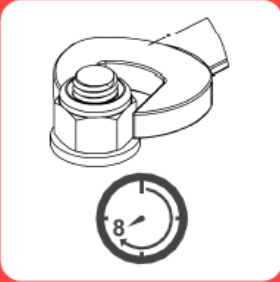
Beware of escaping fluid.

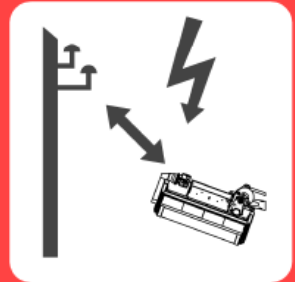
<p>GB Carefully read the Operator's Manual before handling this machine. Observe instructions and safety rules when operating.</p> <p>D Vor inbetriebnahme die Betriebsanleitung und Sicherheitshinweise lesen und beachten.</p> <p>F Lire le livret d'entretien et les conseils de sécurité avant la mise en marche et en tenir compte pendant le fonctionnement.</p> <p>NL Voor ingebruikname de bediening handleiding en veiligheids voorschriften lezen en in acht nemen.</p> <p>DK Laes instruktionsbogen omhyggeligt før De sætter maskinen i gang. Vaer opmaerksom på instruktioner og sikkerhedshenvisninger under arbejdet!</p> <p>NO Les instruksjonsboka grundig før maskinen tas i bruk. Følg in struksjonene og sikkerhets reglene under bruk!</p> <p>SE Läs noga igenom instruktionsboken innan maskinen tas i bruk och följ alltid givna anvisningar och säkerhetsföreskrifter.</p> <p>FI Lue käyttöohje huolellisesti ennenkuin alat käyttää konetta. Noudata käyttö- ja turvallisuusohjeita käytön aikana.</p> <p>PT Leia cuidadosamente o manual de operações antes de iniciar o trabalho com a máquina. Verifique todas as instruções e regras de segurança quando estiver a trabalhar com a máquina.</p>	D A N G E R	   
---	--	---

8770470

Warning

Shut off engine and remove key before performing maintenance or repair work.

Warning

Beware of overhead electrical power lines.

Warning Signs

You are advised to display clear warning signs to indicate the type of machine when working in public places. The signs should be carefully placed at either end of the work site to give advanced warning of the hazard.

Contact your local Highways Authority or Department of Transport for more information.

Roadwork Guidelines:

- On two-way roads, one set of signs should face the traffic in each direction.
- Work should be within 1 mile of the signs.
- Work only when visibility is good and at times of low risk, e.g. NOT during rush hour.
- Vehicles should show an amber flashing light.
- Vehicles should be conspicuously coloured.
- Debris should be removed from the road or path at regular intervals and the operator should wear high visibility clothing.
- Collect all warning signs promptly when the job is finished.

Training

It is the responsibility of the Spearhead dealer to provide instruction on the safe installation, operation and maintenance of the machine in the first instance. Further training is available from Spearhead Machinery Ltd on request, at cost.

Tractor Requirements

- Check your Tractor size and minimum weight on the Specification table
- Before hitching, ensure position control is selected. Do not attempt to hitch in draft control.
- Set wheel width as wide as possible.
- Ballast weight is to be fitted within tractor manufacturer's recommended requirements
- Check chains and stabilisers must be in good working order to hold the machine firmly. Do not operate without checking chains and stabilisers are tight.
- Spearhead particularly recommend 'turn buckle' type stabiliser.
- Set linkage lift rods to an equal length
- Certain machines require a 12V fused electric supply that is controlled by the tractor's ignition key.
- Spearhead particularly recommend three point linkage of ball end type, we do not advise the use of claw type hitching. The quick release latches should be checked, if worn or insecure they may cause accidental damage or personal injury if the machine becomes detached.
- Ensure tractor link arms can be isolated from accidental lifting.

Attaching to the Tractor

It is most important the operator fully understands the procedure for attaching and un-attaching the reach mower to and from the tractor. The following text must be fully understood before attempting to attach the machine. If there is any doubt please contact your supplying dealer or Spearhead Service Department. Failure to follow the correct procedure to attach or unattached the machine could result in personal injury or machine damage. Any resulting damage to a machine is not covered by warranty.

Always be sure to select a level firm surface, such as concrete before attaching to the tractor.

When operating the tractor or machine's controls do so only when seated in the tractor cab. Do not allow anyone to stand on or amongst linkage for any reason.

1. Reverse tractor and attach lower links

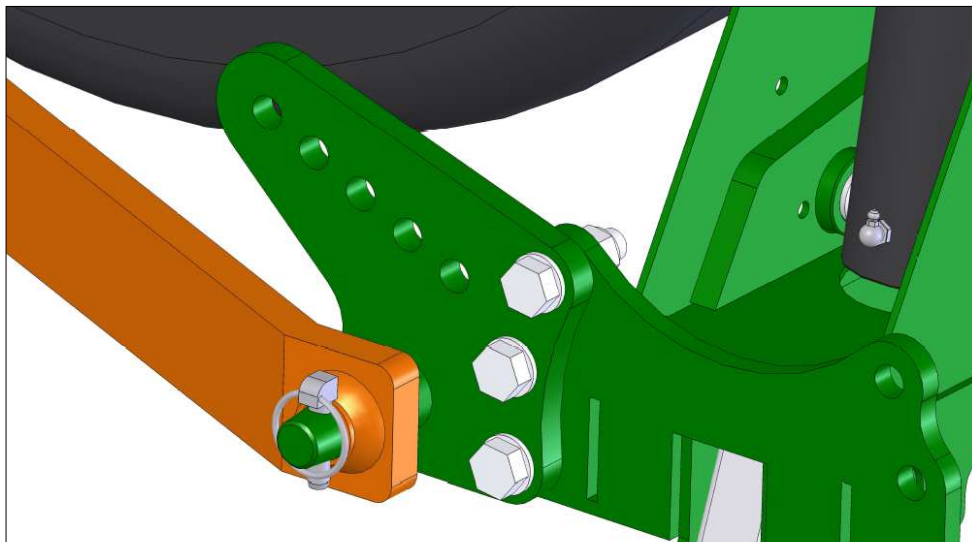

2. Fit stabiliser bracket into top link clevis of tractor then fit the top link

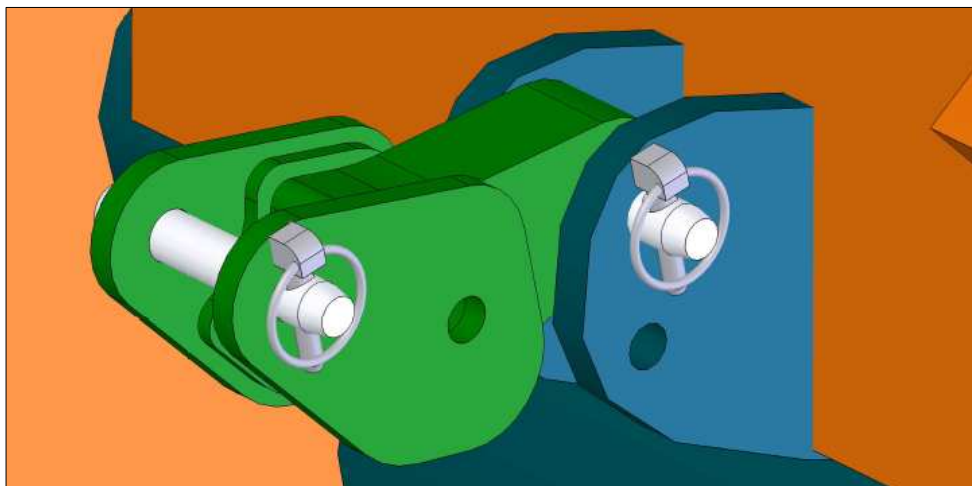

Spearhead TWIGA 320/420

3. Lift machine to required height to allow suitable ground clearance and so that both P.T.O. shafts are roughly in-line

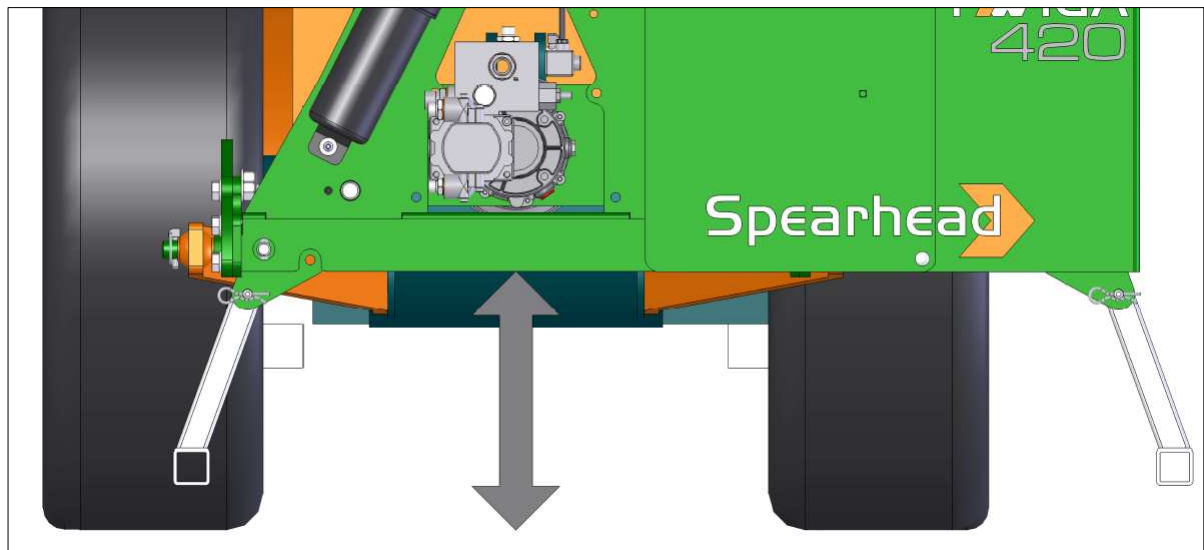

4. Adjust the top link so that the machine sits vertically

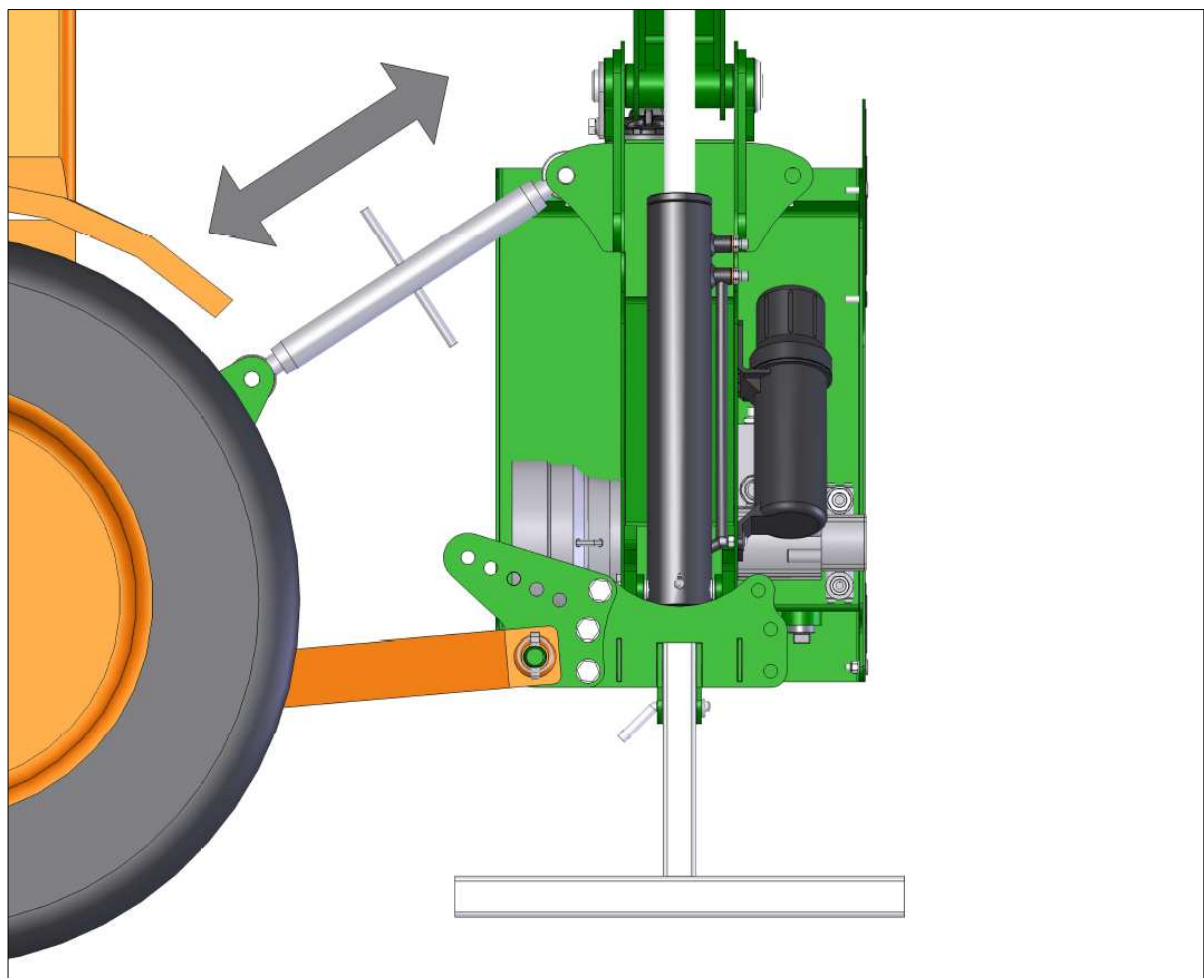

Spearhead TWIGA 320/420

5. Attach stabiliser bars to the nearest available hole, ensure both bars are located in the same hole in both sides. Before fully tightening the bolts, lower the linkage to allow the weight of the machine to be taken by the stabiliser bars, then fully tighten

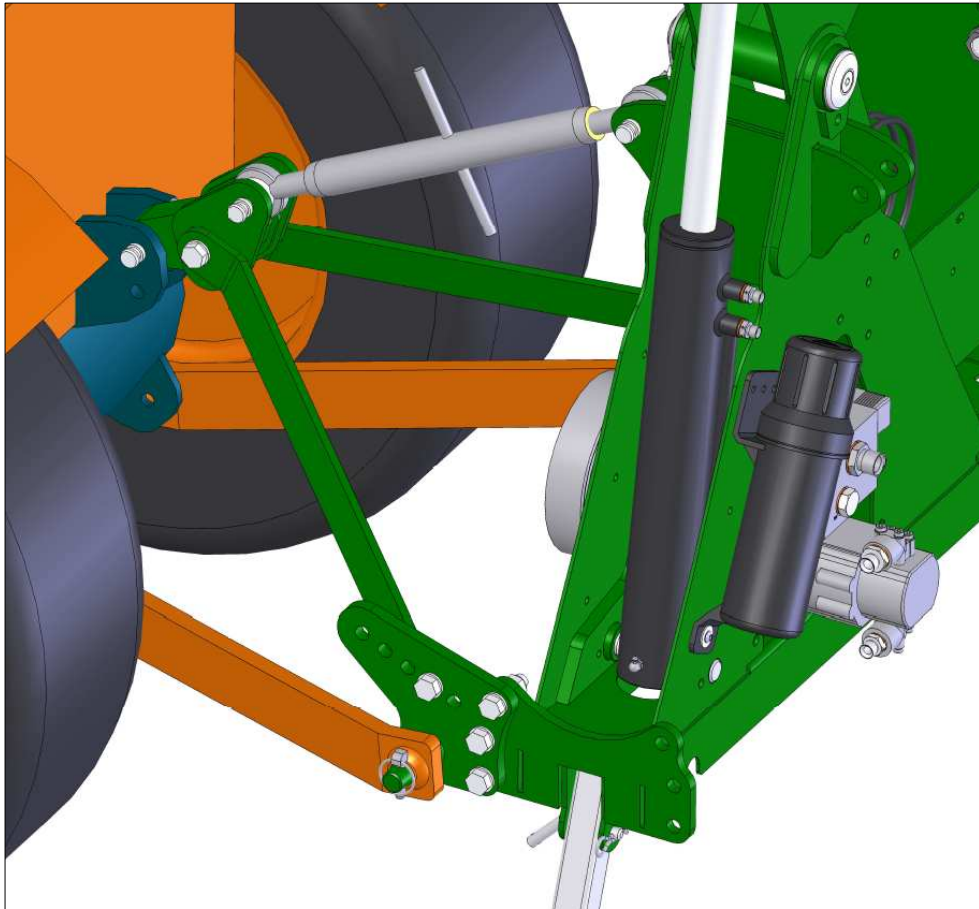

6. Ensure the engine is switched off and then fit the P.T.O. shaft. If fitting for the first time follow instructions below to cut P.T.O. to length. Ensure both sections are cut to equal lengths

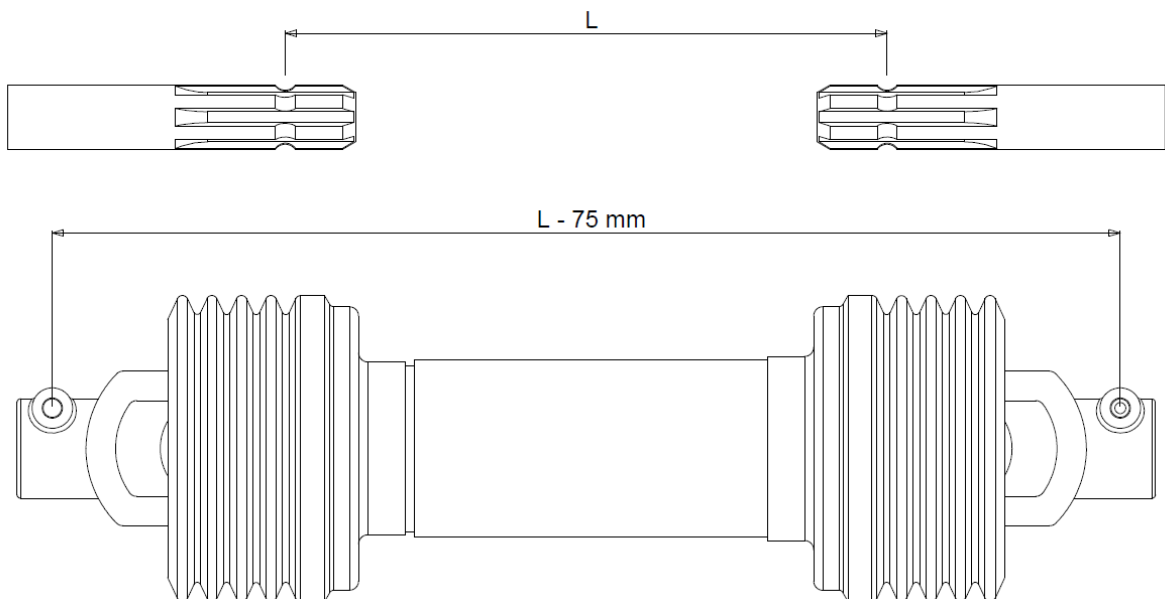

Spearhead TWIGA 320/420

7. Fit the controls to the required position inside the cab. It is recommended that they are fitted to the same side as the cutting head to improve comfort and visibility. On Mini Pilot machines a 12v supply will be required from a fused, ignition controlled source



8. Fold up leg stands to ensure they do not get damaged. Adjust check chains to ensure the machine is secure and cannot swing from side to side. Every machine is supplied with mesh guard panels, these must be fitted to the windows nearest the cutting head. Trim the panels to size and fit to cab with the spring clips provided

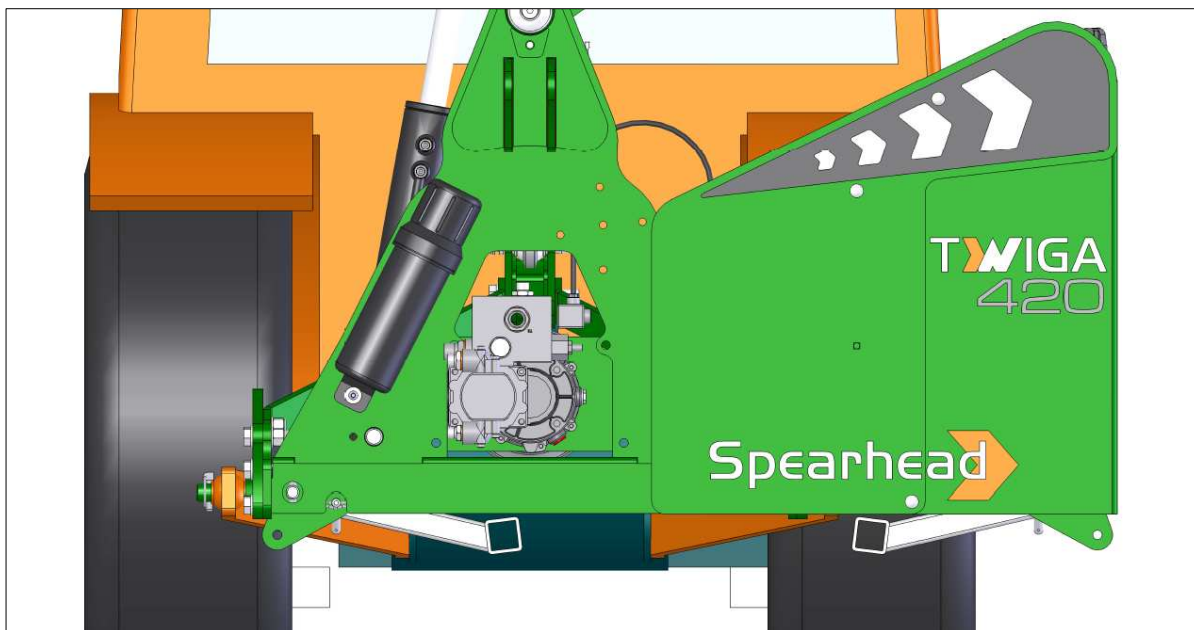

Running Up Your Machine

1. First ensure the rotor is in the 'off' position and P.T.O. drive is disengaged, and then start the tractor.
2. Engage P.T.O. into gear and run machine up to half revs allowing oil to circulate for about 5 minutes before operating arms.
3. Re-check oil level, - check for oil leaks
4. Operate the arms through the full amount of travel, check all movements are functioning correctly.
5. Place flail head near ground in a safe position and with tractor revs low idle, select 'start' position for the flail motor.
6. Once rotor is settled, slowly increase revs of P.T.O. to 540/1000 R.P.M. and run for a further 5 minutes. Slowly reduce revs and then disengage P.T.O.
7. Check all hoses for kinks, pinching, chafing and leaks.
8. Re-check oil level.

Warning

The rotor will take a long time to stop. Never leave the cab until P.T.O. is disengaged, engine stopped and rotor has stopped spinning.

Removing From The Tractor

1. Select a level firm site such as a concreted surface
2. Lower leg stands. Place the flail head on the ground approximately 1m out from machine main assembly
3. Disengage P.T.O.
4. Slightly raise lower link arms with great care, enough to carry sufficient weight to remove both stabiliser locking bolts
5. Lower all weight securely onto parking stands.
6. Stop engine; ensure all weight is off the tractor and machine hydraulics by operating the levers in all directions.
7. Remove top link, lower link pins, P.T.O. shaft, and control unit from the cab.
8. Slowly drive tractor away

Spearhead TWIGA 320/420

Cable Controls - LH

ROTOR BACKWARDS

HEAD OUT/FLOAT

DIPPER OUT

LIFT DOWN

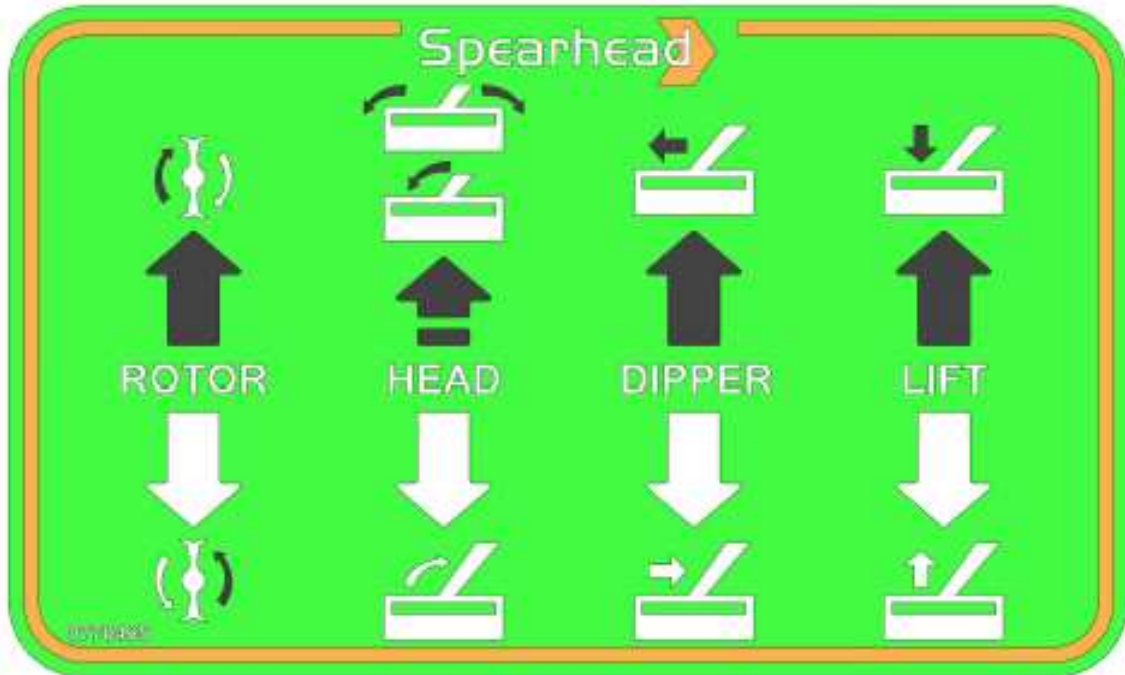

ROTOR FORWARDS

HEAD IN

DIPPER IN

LIFT UP

Cable Controls - RH

LIFT DOWN

DIPPER OUT

HEAD OUT/FLOAT

ROTOR FORWARDS

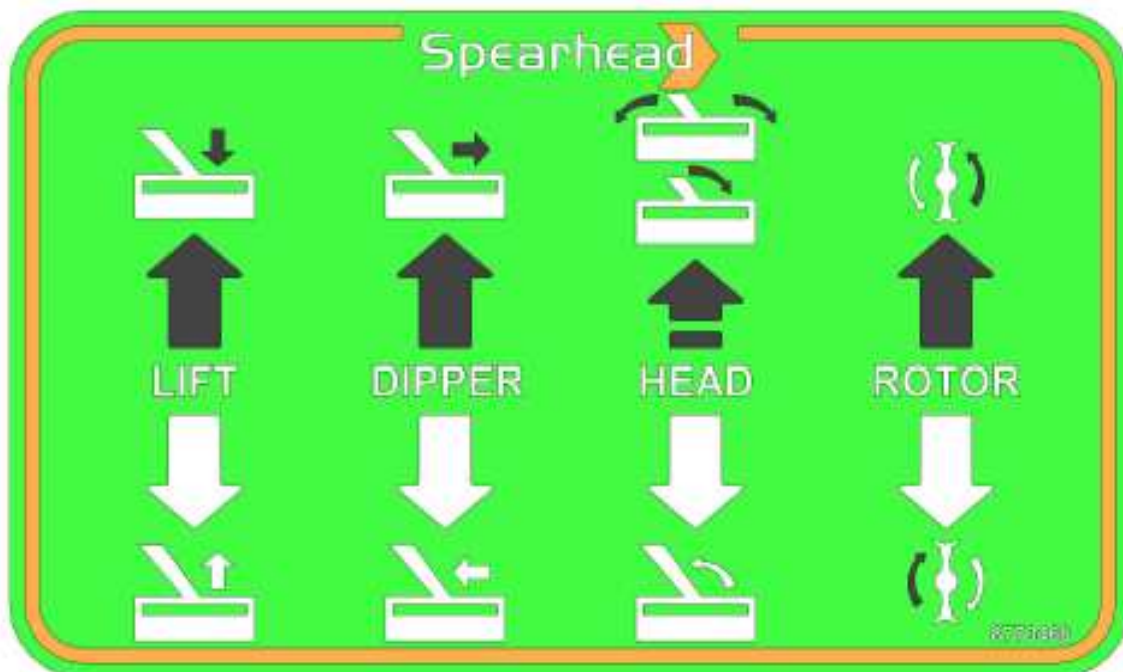

LIFT UP

DIPPER IN

HEAD IN

ROTOR BACKWARDS

Spearhead TWIGA 320/420

MINIPILOT Controls

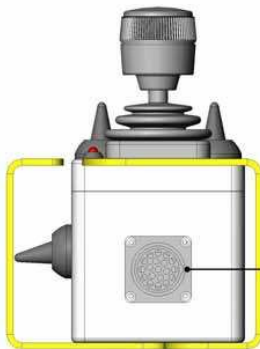
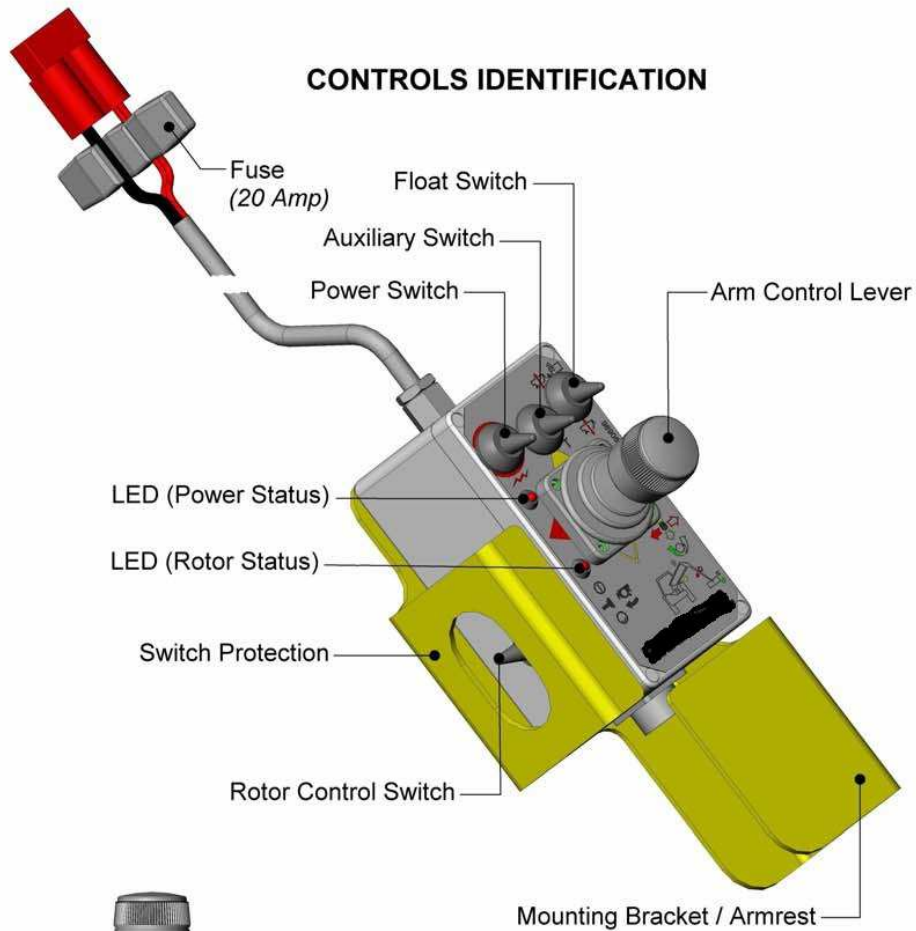

ELECTRICAL CONNECTIONS

- A - COMMON
- B - REACH IN
- C - REACH OUT
- D - LIFT UP
- E - LIFT DOWN
- F - COMMON
- G - N/A
- H - N/A
- J - ANGLE DOWN
- K - ANGLE UP



- L - N/A
- M - N/A
- N - COMMON
- P - ANGLE FLOAT
- R - LIFT FLOAT
- S - PUMP 1
- T - AUXILIARY
- U - N/A
- V - CUT OFF

Spearhead TWIGA 320/420

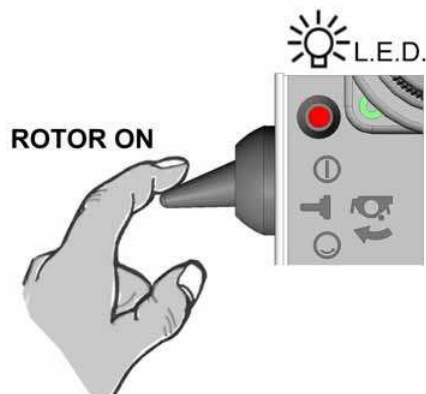
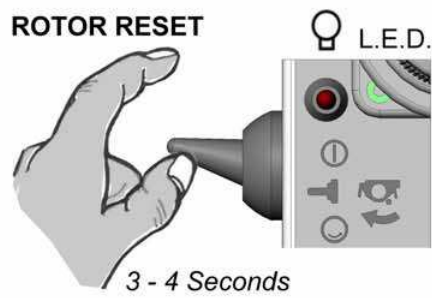
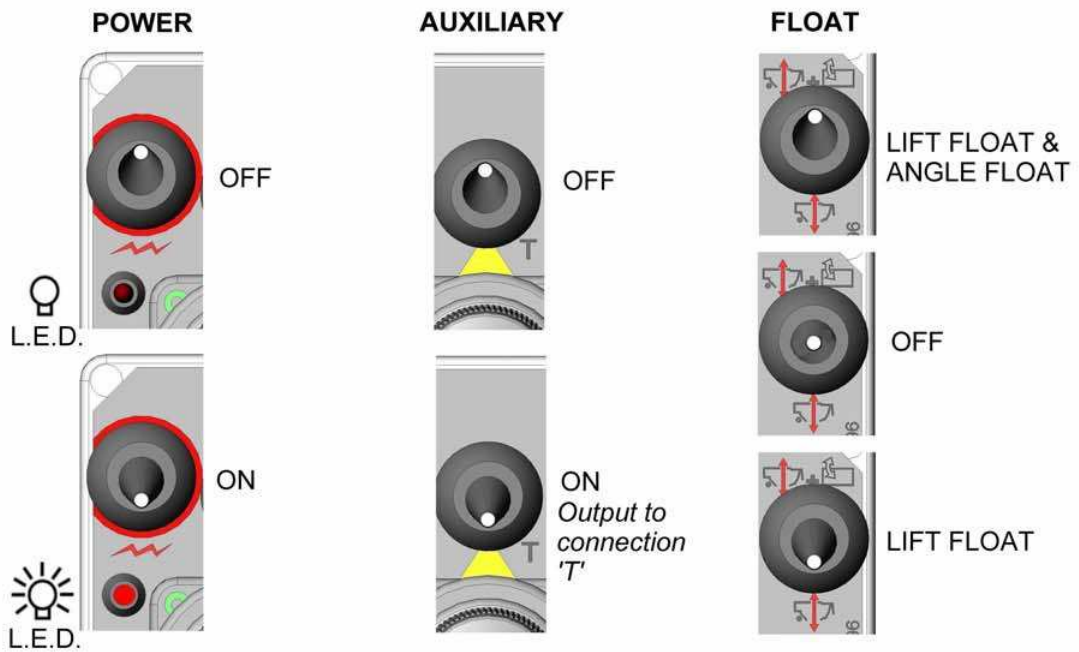

Spearhead TWIGA 320/420

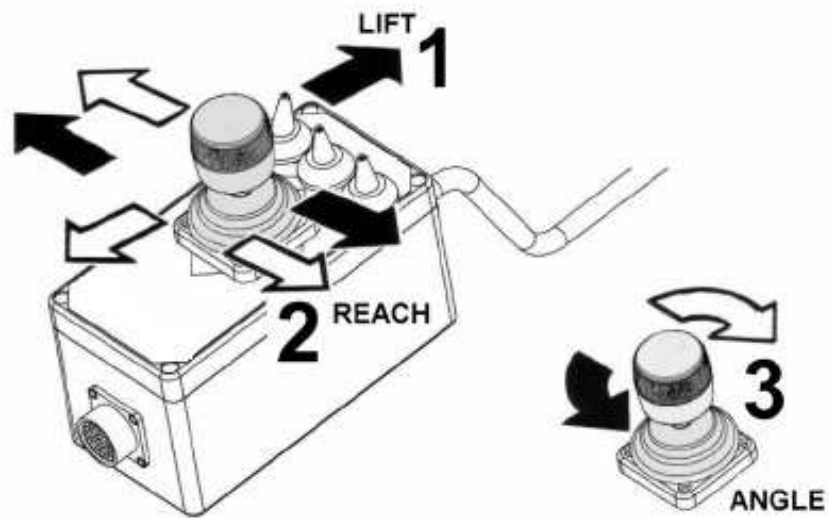

Before commencing work it is advisable to find an unobstructed level site and operate the machine through its entire range of movements to familiarise yourself with the controls and the machines response to them. This is a wise precaution for all operators and a must for the inexperienced.

Operational Warnings

- Never drive the tractor with arm out stretched (except when cutting). When moving at work always first retract arms. Transport with care. Metal fatigue is always caused by careless transportation and misuse. If the ground is uneven or bumpy slow down.
- Read operator's manual and be fully familiar with all operational maintenance and safety procedures.
- Practice in open space without rotor running until familiar with controls. Take care working the head close to the tractor as it may be possible to strike the tractor.
- Remember one of the clever features of the TWIGA range is its ability to operate within a very narrow space, often within the tractors width. This will mean it is quite possible for the flail head to foul the tractor. Practice all these positions and be very familiar with your machine before ever attempting work.
- Never operate above the recommended P.T.O. speed of 540/1000 R.P.M. failure to heed this warning will result in severe damage, i.e. greatly increased oil temperature, risk of rotor going out of balance, as well as reduced machine life, and could cause expensive repairs.
- Failure to start and stop the rotor at a low P.T.O. speed or to operate at the correct speed will result very quickly in severe motor and/or pump damage.
- Be very careful when operating on sloping ground.
- Never attempt to operate the machine while going backwards. It will immediately damage the arms and possibly the flail head. Remember, before selecting reverse gear always lift the flail head out of work and retract the arms towards the tractor.
- Never operate with flail rotor facing towards the tractor. This is potentially dangerous with debris being thrown towards the tractor, and unseen hazards may cause damage.

Operation

Engaging Flail Head Drive

1. Select 540/1000 R.P.M. P.T.O. and run with **low** engine revs.
2. With flail head in safe position move rotor control lever or switch to 'on'.
3. **Cold start** - it is important not to run at full speed with cold oil. Run at half speed for 5 minutes to allow oil to warm up.
4. After 10 seconds slowly increase engine revs to obtain correct P.T.O. speed.
5. Never attempt to start rotor while under load.

Disengaging Flail Head Drive

1. Slowly decrease engine revolutions to a fast idle.
2. Move rotor control lever or switch to 'off'
3. Never increase or decrease P.T.O. speed rapidly, this could seriously damage pumps and motor.

Transport To Work Position

1. Ensure rotor is off, engage P.T.O. at low revolutions.
2. Position head vertical 90°
3. Lower main lift ram only until main arm is vertical.
4. Extend dipper arm outward.
5. Position head till horizontal, just above ground.

Moving Into Transport Position

1. Disengage head motor drive.
2. Set main arm to 45° from the ground.
3. Slowly bring dipper arm in until it meets the main arm rubber cushion.
4. Set the cutting head position to vertical.
5. Raise the main lift ram and closely monitor cutting head position, ensure it reaches no more than 200mm from the tractor.
6. Disengage P.T.O.
7. Avoid high speed transport speeds which could cause unnecessary strain on the machine or tractor, always ensure the two arms are closed fully together.

Break Back

The TWIGA range of reach mowers have, as standard, a breakaway ram for machine protection, should an obstacle be encountered while travelling forward

The break back ram will operate if the machine is overloaded i.e. a dense patch of vegetation, too high a forward speed, and when working uphill. The tractor must be halted and flail head manoeuvred around the obstacle, the machine then reset before continuing.

Cutter Bar

Description

The optional 1.5m cutter bar is a robust construction of double fingers and reciprocating knife, suitable for cutting shrubs and hedges of a woody material up to 30mm diameter.

Operation

Run the PTO at low speed 150/200 rpm only; normal 540 R.P.M. will cause unnecessary wear and vibration, which may lead to premature failure. Position the arm and knife into the work and select a suitable forward speed, which allows the blade to cut all material without blocking. When trimming material towards the limit of the cutter bar avoid making arm movements and reduce your forward speed to allow the knife to time to clear.

Maintenance

- Grease motor body (5 pumps every 50 hours)
- Grease knife drive (1 pump every 50 hours)
- Check tightness and security of all nuts and bolts
- Sharpen or replace worn or damaged blades and fingers

Safety

- When cutting material take care as the branches may fall towards the tractor, always using appropriate guarding on cab glass.
- Never attempt to unblock a jammed knife by hand, always use a suitable tool.
- Always ensure the knife guard is in place before transporting machine.
- Always position the arms and cutter bar on the ground or stands before attempting any maintenance.
- Always disengage the P.T.O. and switch off the engine before attempting and maintenance on the cutter bar.
- Always ensure the engine is switched off, the key removed and the knife has stopped before dismounting the tractor.
- Ensure no person or vehicle is in danger from falling debris in the working area.
- Inspect the work area for hidden obstacles, wire, posts, rocks etc, which may damage the blades or machine.
- Avoid angling the arms or cutter bar into a position, which may contact the tractor, causing damage.

Head Float

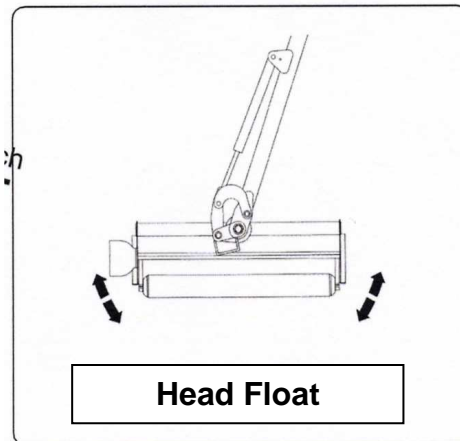

This option allows the flail head to follow contours of the ground without having to constantly control the angle of the head.

The centre of balance is the best mounting point for the head if head float is to be used properly.

Operating The Head Float

Place flail head on the ground and switch on head float control/operate lever, this opens the head ram to tank, and allows the ram to float in or out, maintaining full contact with the ground automatically.

To regain manual control switch off float.

Warning

Do not fold the machine up for transport before turning off the head float.

Arm Float

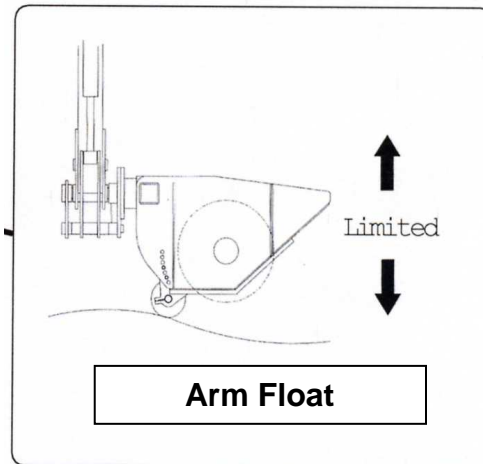

This is only to be used in verge mowing set up, it will reduce weight on the rear roller allowing head to move more easily, following small changes in ground contours in a forward motion, with the aid of a pre-charged gas accumulator.

Operating The Arm Float

To select arm float, first lower the flail head to the ground before operating the switch. The main lift control lever should be operated to take a proportion of the flail head weight off the rear roller. This is important, as too little weight on the rear roller will leave uncut areas of grass, too much weight on the roller will cause scalping in places and increase flail wear and damage. We strongly recommend the use of auto reset - break back.

When the head is pushed further out more weight will be applied to the accumulator causing the head to drop, reset with control lever.

As the ground contours alter it is necessary to reset the pressure within the main lift circuit as above, constantly raising or lowering control lever.

Warning

Do not fold the machine up for transport before turning off the arm float and discharging the pressure from the lift circuit.

Oil Cooler

The optional fitment of an oil cooler prolongs the life of the hydraulic oil and components in hot and arduous conditions.

It is important to connect the power lead to the control box directly to the tractor battery.

It is essential to keep the radiator clear from debris to ensure a free air flow that will effectively keep the oil cool.

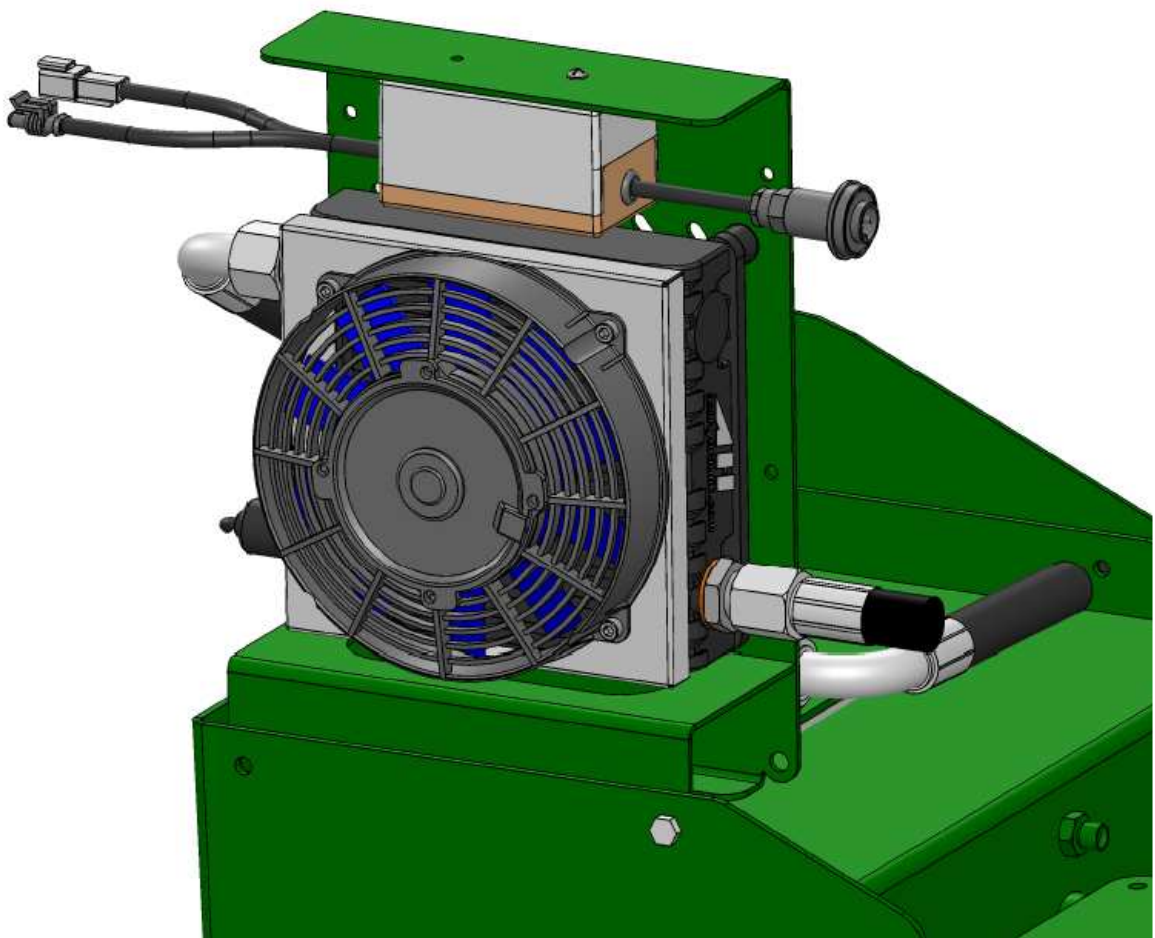

Spearhead TWIGA 320/420

Lubrication Chart

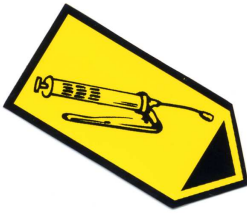

All the following grease points
Need to be greased daily.

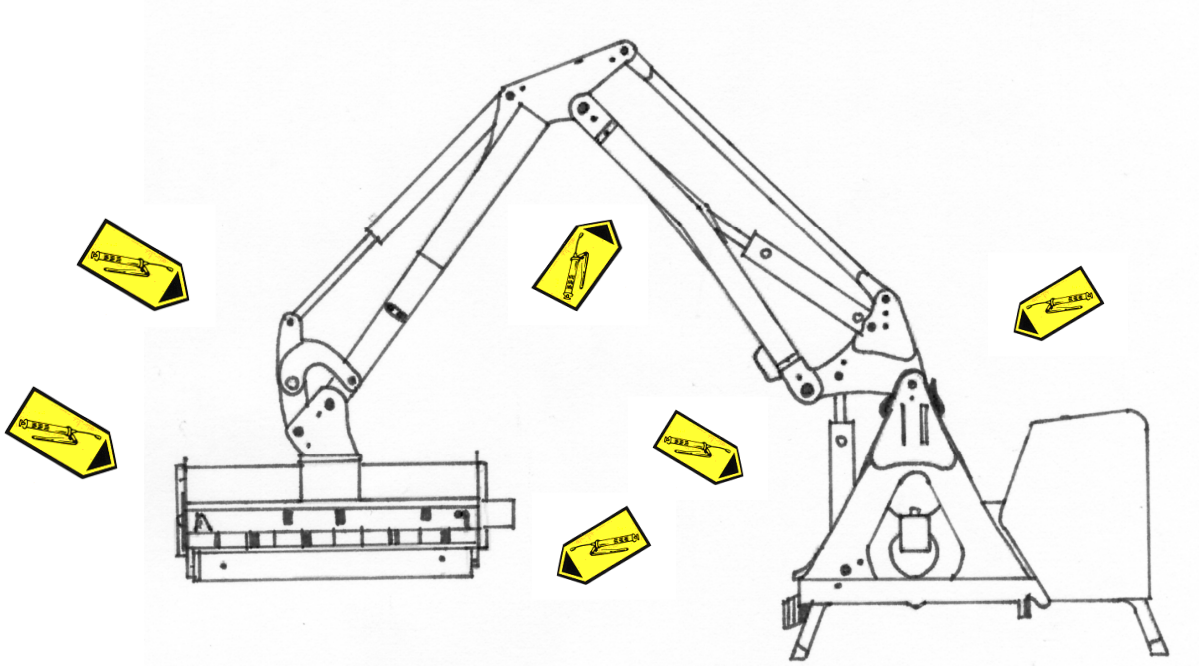

	Daily	Weekly	Monthly
Rotor shaft bearings			
P.t.o. shaft bearings			
P.t.o. shaft tubes			
Pivot pins			
Roller bearings			
Oil tank			
Gearbox			
Motor drive			
Flail head			

Key:

Grease =

Oil =

Check =

Spearhead TWIGA 320/420

Greasing/Lubrication

Washing your machine

Grease all your machine and optional parts after each time you wash your machine.

Gearbox

Before first use check gearbox oil level, thereafter check every 8 hours. After the first 50 hours drain and replace the gearbox oil, thereafter annually. Replace with EP90. Do not over tighten oil plugs, as this will damage the housing.

P.T.O.

Dismantle; clean the input drive shaft sliding surfaces and re-grease, failure to do this will result in serious damage to the gearbox. Grease both U.J. joints every 8 hours.

Oil Requirements

Fill the tank to centre of sight gauge with approximately 220 litres of HD46 or equivalent oil. Do not over fill.

Torque Settings

The Torque figures given below are recommended maximum settings only.

Size:	Tensile strength:	Description:	Torque setting: Nm.
M10	8.8	General fasteners	65
M12	8.8	General fasteners	114
M12	12.9	Head bolts	170
M12	10.9	Flail bolts	100
M16	8.8	Head bracket bolts	280

Spearhead TWIGA 320/420

Hydraulic Hoses

- Carefully check condition of all hoses during routine service paying particular attention to chafed outer casing. Secure wrap with waterproof adhesive tape to stop the metal braid from rusting.
- Daily inspect all hydraulic hoses and fittings to be in good order. Any damages or leaks must be rectified immediately; this is part of the daily maintenance and is your responsibility, to ensure a long reliable working life.
- Hoses with damaged metal braid should be replaced.
- When replacing hoses quote number stamped on fitting at one end. The Spearhead hydraulic system works at very high pressure, when replacing hoses use only genuine hoses, a burst hose could be very dangerous.
- When replacing hoses to avoid twisting fitting, use two spanners to slacken and tighten.

Warning

Hose is weakened when installed in twisted position. Also, pressure pulses in twisted hose tend to fatigue wire and loosen fittings.

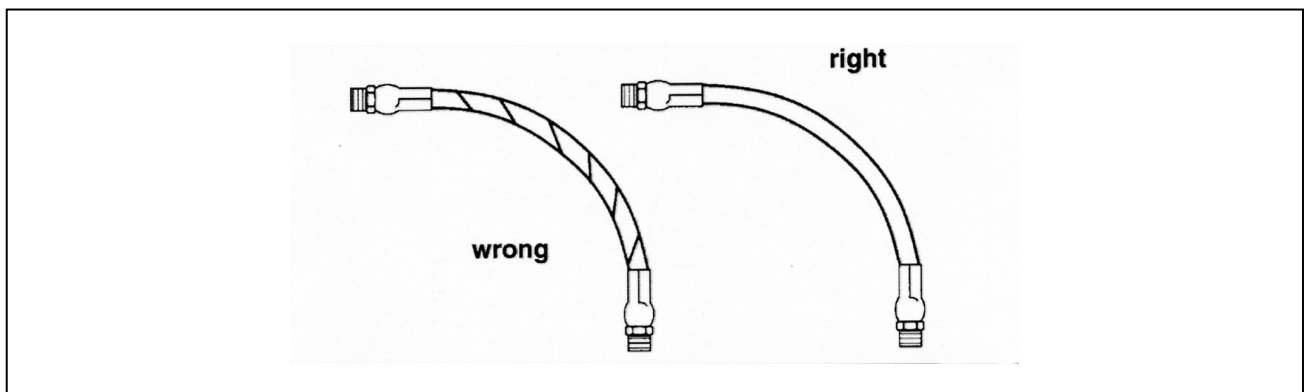

- Always check the black protective sleeve is in good order, to replace sleeve is far cheaper than replacing expensive hoses.
- Hose warranty is limited to replacement of hoses due to faulty materials or manufacture Warranty will not be considered on hoses damaged by chafing, abrasion, cuts or pinching while in work, or to damaged threads due to over tightening.
- All hose connections are of a "Parker" soft seal type and only need 1/2 a turn more than finger tight to become leak-proof.

Oil Supply

- Daily before starting up check oil level in tank reservoir.
- It is a good practice to constantly keep an eye on the tank level gauge, (this can be seen from the tractor seat) as a pipe burst could empty the tank within minutes.
- A pump or motor starved of oil will be damaged beyond repair.
- Replace oil if signs of contamination occur (discoloured)
- Contamination can be reduced by:
 - Thoroughly cleaning around reservoir cap before removing.
 - Using a clean container when replenishing the system.
 - Regularly servicing the filtration system.
 - Never allowing oil level to fall below the sight gauge.
- Daily inspect all hydraulic connections and fittings to be in good order. Any damage or leaks must be rectified immediately, this is part of the daily maintenance and is your responsibility, to maintain a long reliable working life.
- When tightening fittings always use two spanners when necessary and do not over tighten. If a fitting leaks it will need to be replaced.

Filtration Maintenance

The machine is protected by a suction strainer and a low pressure full flow return line filter.

1. The suction filter is permanently fixed in the reservoir tank. Should symptoms of pump cavitations or spongy operation occurs, the tank must be drained, the tank and suction filter thoroughly cleaned and dried before refilling with clean oil.
2. The return line filter element should be replaced after the first 50 hours and thereafter at 300-hour intervals. It is most important to replace the filter within these intervals because once blocked, oil will bypass the filter element infiltrated.
3. When tightening fittings always use two spanners when necessary and do not over tighten. If a fitting leaks it will need to be replaced.

Pins & Bushes

All main pivot points are furnished with replaceable bushes. If there are any signs of wear, these must be replaced. All bushes are available from Spearhead Parts Department.

Warning

Do not use grease containing Molybdenum disulphide on nylon bushes and wear pads.

Storage

Remember regular maintenance will greatly increase the life of the machine.

Before storing away, thoroughly wash the machine removing all traces of grass and dirt. Care must be taken when washing with high-pressure hoses, do not hold the water jet close to the paintwork. Use steam cleaners with caution, be sure to remove all detergents to avoid any discolouring or damage to paint. Grease all grease points until fresh grease shows. It is important where possible to store undercover to protect against rain and sunlight. Always ensure a firm level surface.

Smear greaser on all areas vulnerable to corrosion, in particular the chrome on the ramrods.

Before you attempt to do any repairs, service, maintenance or adjustment on your machine, ensure the engine has stopped and the key removed. P.T.O. is disengaged, handbrake secure, and the head is firmly on the ground.

Control levers must be wrapped in plastic sheeting and taped over to keep dry.

PROPILOT controls should be removed and stored in a safe and dry area.

Spearhead TWIGA 320/420

Regular Services Chart

Service Hours	Service points	Grease	Drain	Check	Clean	Change
1-4 hrs	Bolts are fully tightened			X		
	Condition of flails			X		
	Condition of hoses especially for chafing			X		
	Flail bolts are fully tightened			X		
	Flail head retaining bolts are fully tightened			X		
	Gearbox seals (If oil is leaking replace immediately)			X		(X)
	Inspect leaks from fittings and pipes			X		
	Pins and bushes			X		
	Rotor bearing bolts are fully tightened			X		
8 hrs	Bearings	X				
	Gearbox & pump bolts are fully tightened			X		
	Gearbox oil level			X		
	Grease points & PTO shaft	X				
	Motor Drive	X				
	Maintain correct belt tension on head (only with belt drive heads)			X		
	Oil level in reservoir	X		X		
	U.J. joints					
50 hrs	Gearbox oil (use EP 90 oil)		X			X
250-300 hrs	Return line filter element					X
	Hydraulic oil if any signs of contamination appears		X	X		

Pump & Motor Failure Prevention

- Never run out of oil.
- Never run a cold machine straight up to speed, first ensure engine revolutions are low then engage/disengage the head motor.
- Never increase or decrease engine speed quickly.
- Never stop or start rotor at high engine speed.
- Never transport with P.T.O. in gear.
- Regularly check condition of suction line hose.
- Never operate above recommended P.T.O. speed.
- Check that pump fittings are tight.
- If any strange noise occurs from the hydraulics, stop immediately and investigate.
- Remember, pump and motor warranty is limited to replacement due to faulty materials or manufacturer. Cavitations and peak pressures are very easily detected on pump inspection.
- Warranty will not be considered if fault is due to misuse.
- Never cause severe sudden movements to arms. Pressure will peak and will transmit back to pump, resulting in failure.

Spearhead TWIGA 320/420

Trouble Shooting

Problem	Cause	Solution
Gearbox overheating	Oil level incorrect	Check oil level
	Oil grade incorrect	Check oil grade
	Implement overloaded	Reduce forward speed
	Wrong PTO speed	Ensure tractor PTO speed matches implement
Excessive belt wear	Belt and pulley condition	Replace if necessary
	Pulley alignment	Check alignment
	Incorrect belt tension	Tension belts to spec
	Overloading of implement	Reduce forward speed or increase height of cut
P.T.O.. wear U.J. failure	Working angle too great	Reduce offset of implements
	Shaft incorrect length i.e. bottoming out	Resize PTO shaft as recommended
	Lack of maintenance	Grease PTO shaft as recommended
Cut Quality	Flails worn	Replace worn flails
	Rotor speed/direction	Check tractor PTO speed
	Crop condition	Look for suitable conditions
Rotor bearing failure	Rotor out of balance	See rotor vibration
	Wire/string in bearing	Remove wire/string
	Lack of maintenance	Grease bearings to schedule
	Water in bearing	Expel water with grease
Rotor vibration	Flails broken or missing	Replace flails
	Bearings worn or damaged	Replace bearings
	Rotor bend	Re-balance/replace rotor
	Build up of debris	Remove debris
	Incorrect speed	Check rotor R.P.M.
Oil tank overheating	Oil level incorrect	Fill tank to correct level
	Oil grade incorrect	Drain and refill tank with correct grade oil
	PTO speed too fast	Ensure the tractor's PTO speed matches implement
	Ambient temperature too high	Reduce work rate / install oil cooler
Break-back operating Frequently	Machine overloaded	Reduce forward speed or increase height of cut
	Machine being used on excessive incline	Switch off auto reset
	Weight of machine being carried upon rear roller	Use Autopilot or head float
	Machine not set vertical	Shorten top link
Hydraulics not responding	Oil level low	Fill oil to correct level
	Oil pump suction filter blocked	Replace filter element
	Oil leak in pressure line	Check machine of leaks
	Drive line broken	Check pump is rotating
Joystick control sluggish	Air in pilot lines from joystick	Slacken off each line of pilot circuit individually at spool valve whilst operating. When all air is expelled retighten the line

Spearhead TWIGA 320/420

Trouble Shooting

Problem	Cause	Solution
Irregular arm movement	Spool contacting with housing	Check spool is free moving
	Broken spring in spool valve	Check spring
	Failed ram seals	Repair ram
Electrically operated valve not responding	Faulty wiring	Check wiring and switches
	Dirt in valve	Check of ingress of dirt
	Sticking valve	Replace the valve
	Insufficient voltage	Attend to bad connection

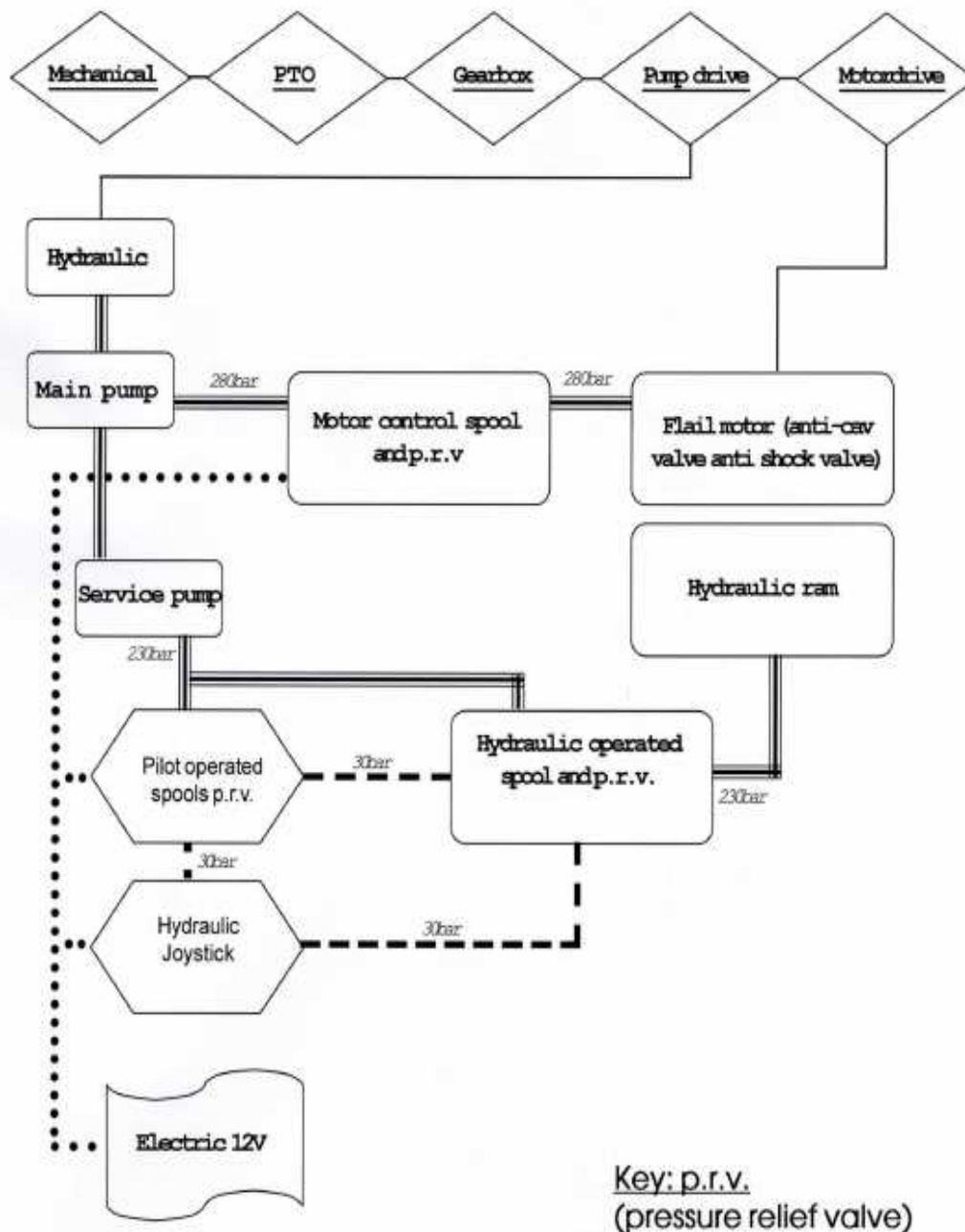

Spearhead Machinery Ltd
Green View
Salford Priors
Evesham
Worcestershire
WR11 8SW
Tel: 01789 491860
Fax: 01789 778683
www.spearheadmachinery.com
enquiries@spearheadmachinery.com