

ITEM NO.	QTY.	PART NUMBER	DESCRIPTION	DRAWING NUMBER	WEIGHT IN kg	VENDOR	VENDOR PART No
1	1	TTR100	TYNE FRAME FABRICATION	TTR - 100	72.08		
2	3	TTR101	TYNE LEG FABRICATION	TTR - 101	18.51		
3	2	LPB215	HEAVY DUTY PIN	Purchased	0.43	Bare Co	B215
4	1	LPB74	PIVOT PIN	Purchased	0.30	Bare Co	B74
5	3	LP10D	10mm LYNCH PIN	Purchased	0.05	Bare Co	B6
6	6	HHB5_8UNF-18T3.0	5/8UNF x 3" HEX BOLT	Purchased	0.16	MAPTCO	TBA
7	6	WF16M	M16 FLAT WASHER	Purchased	0.01	TBA	TBA
8	6	HNN5_8UNF	5/8" UNF HEX NYLOC NUT	Purchased	0.05	MAPTCO	TBA
9	3	TBB9709	FLAT CHISEL POINT	Purchased	3.35	Bare Co	B9709
10	6	PBB2555	1/2"x2" UNC PLOUGH HEAD BOLT W/- NUT	Purchased	0.08	Bare Co	B2555
11	6	SW12	M12 SPRING WASHER ZN PL	Purchased	0.01	TBA	TBA

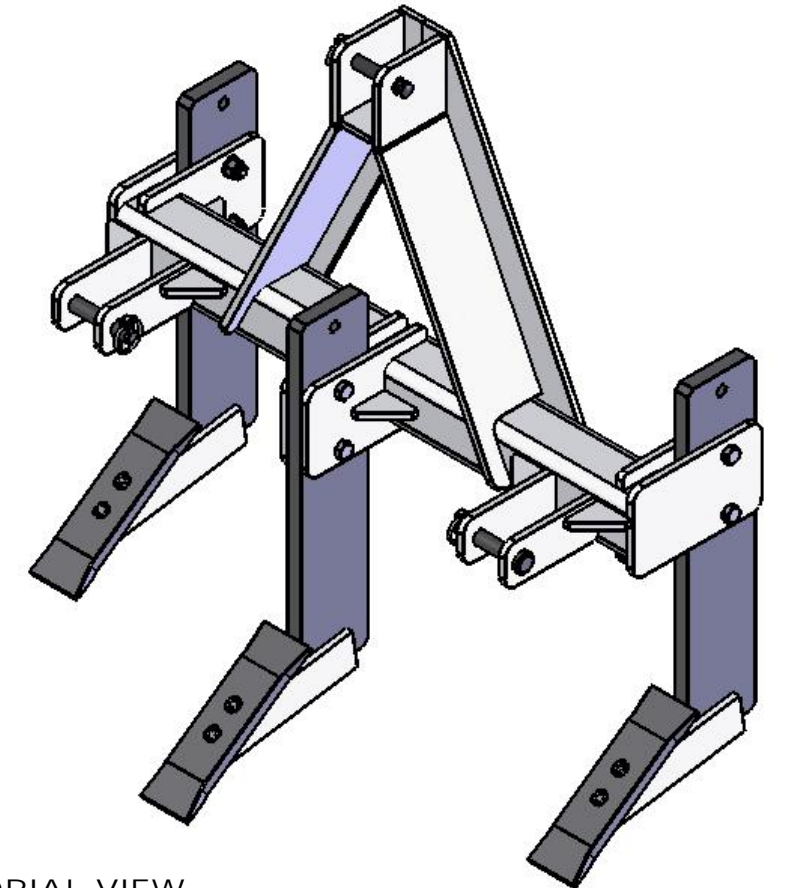
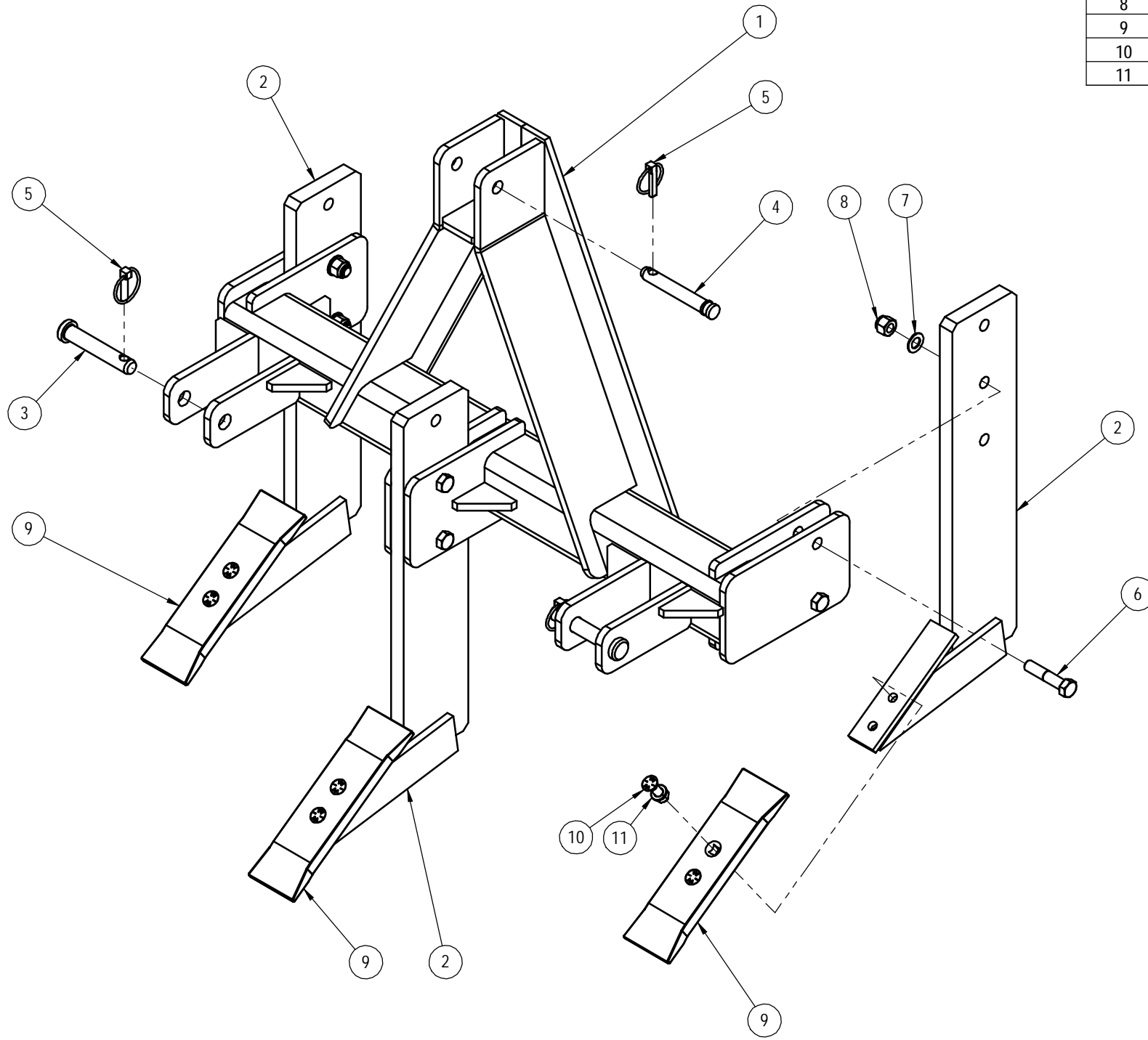

PICTORIAL VIEW

DO NOT SCALE
IF IN DOUBT - ASK WEIGHT 140756.9 GMS

Sheet 1 of 1

No.	Description	DWN	CHK	APPD	DATE
P1	PRELIMINARY DRAWING	-	-	-	-
A	APPROVED FOR CONSTRUCTION	-	-	-	-

199 Bridge Street, Oakey, Qld, 4401

THIS DRAWING IS PRIVATE AND CONFIDENTIAL AND REMAINS THE PROPERTY OF FIELDQUIP.
RETURNED UPON REQUEST. IT MUST NOT BE COPIED OR LOANED WITHOUT THE CONSENT OF FIELDQUIP.

SCALE	1:7.5	U.N.O
Design	D.M.	2014
Drawn	AWP	14.06.14
Check	D.M.	20.06.14
Appd.	D.M.	20.06.14

THREE TYNE RIPPER ASSEMBLY
THREE TYNE RIPPER

3rd ANGLE PROJECTION U.N.O.	A3
Fieldquip Drawing Number	REV
TTR - 500	A

ITEM NO.	QTY.	PART NUMBER	DRAWING NUMBER	WEIGHT IN kg	DESCRIPTION
1	1	TTR010	TTR - 10	15.2	TYNE LEG
2	2	STR008	STR-008	1.2	RIPPER SIDE SUPPORT PLATE
3	1	STR009	STR -009	0.8	RIPPER POINT PLATE

NOTE: ALL WELDS 6mm CFW UNO. WHERE WELDS ARE DIFFICULT TO ACCESS USE FABRICATOR'S DISCRETION.

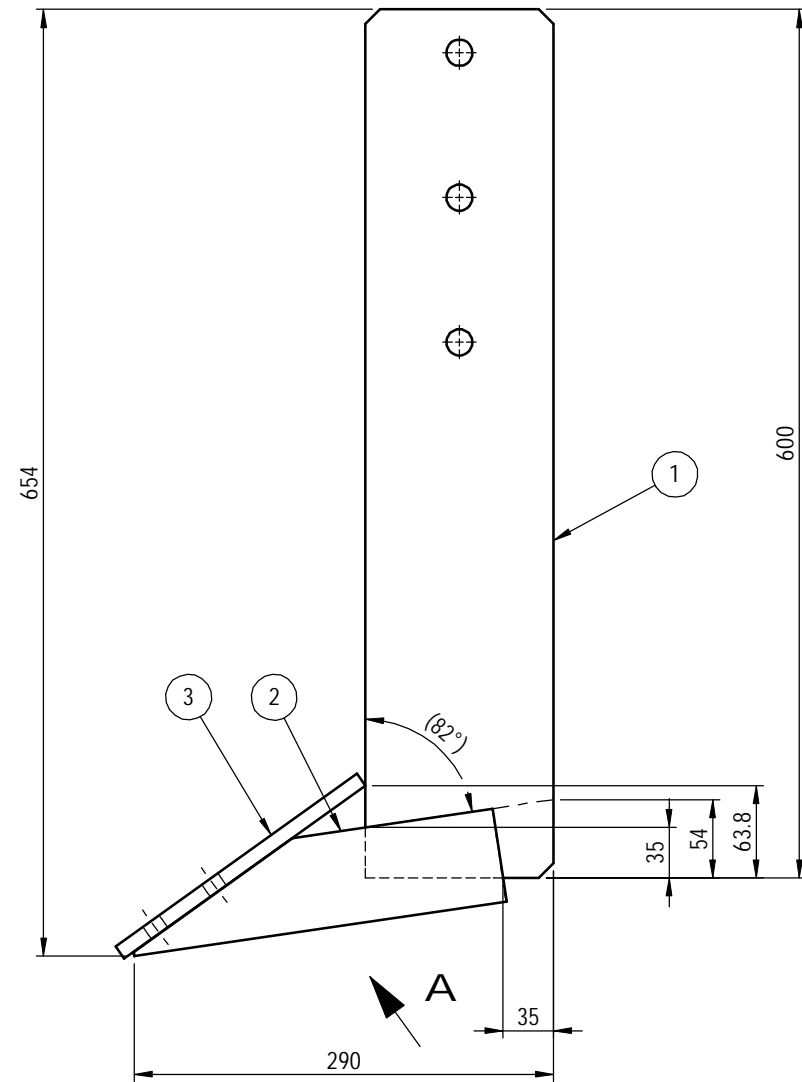

FRONT VIEW

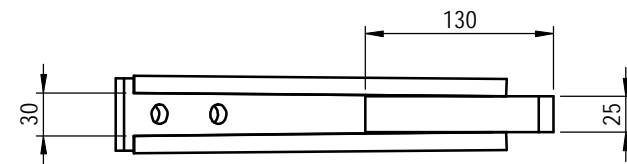

UNDERSIDE VIEW

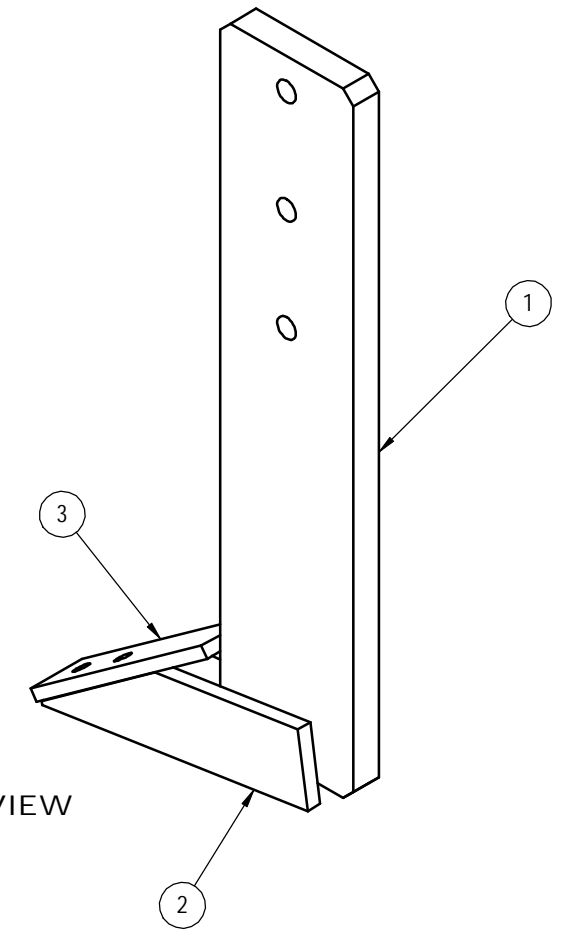

ISOMETRIC VIEW

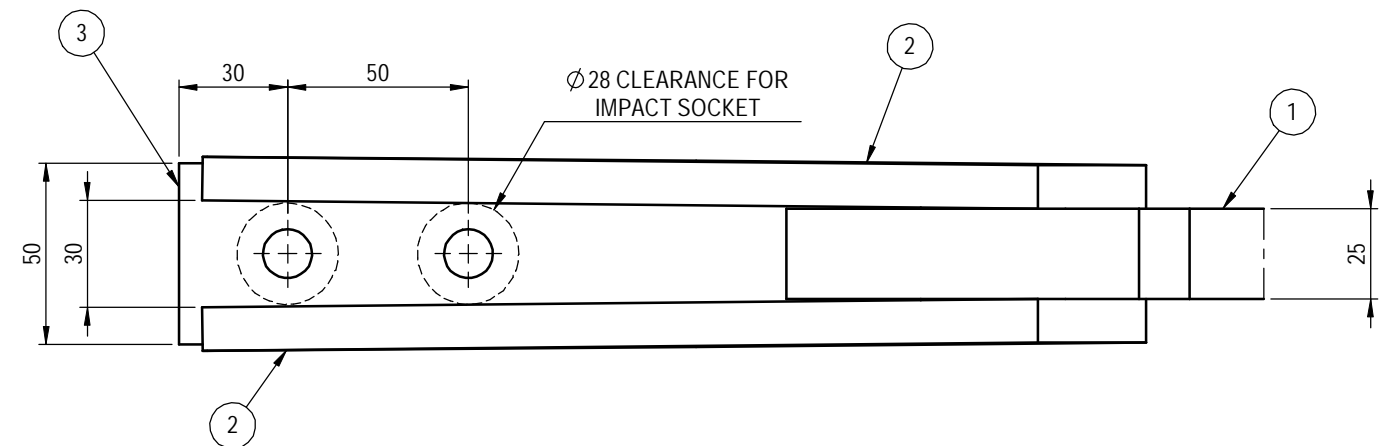

VIEW A (1 : 2)

DO NOT SCALE
IF IN DOUBT - ASK WEIGHT 18510.7 GMS

Sheet 1 of 1

No.	Description	DWN	CHK	APPD	DATE
P1	PRELIMINARY DRAWING	-	-	-	-
A	APPROVED FOR CONSTRUCTION	-	-	-	-

199 Bridge Street, Oakey, Qld, 4401

FIELDQUIP
Australian owned family business

THIS DRAWING IS PRIVATE AND CONFIDENTIAL AND REMAINS THE PROPERTY OF FIELDQUIP.
RETURNED UPON REQUEST. IT MUST NOT BE COPIED OR LOANED WITHOUT THE CONSENT OF FIELDQUIP.

SCALE	1:5	U.N.O
Design	D.M.	2014
Drawn	AWP	14.06.14
Check	D.M.	20.06.14
Appd.	D.M.	20.06.14

TYNE LEG FABRICATION
THREE TYNE RIPPER

3rd ANGLE PROJECTION U.N.O.	A3
Fieldquip Drawing Number	REV
TTR - 101	A

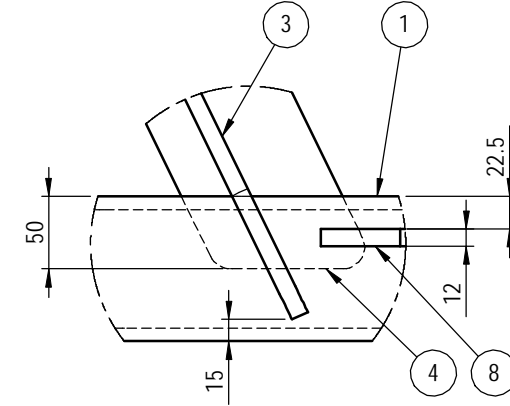
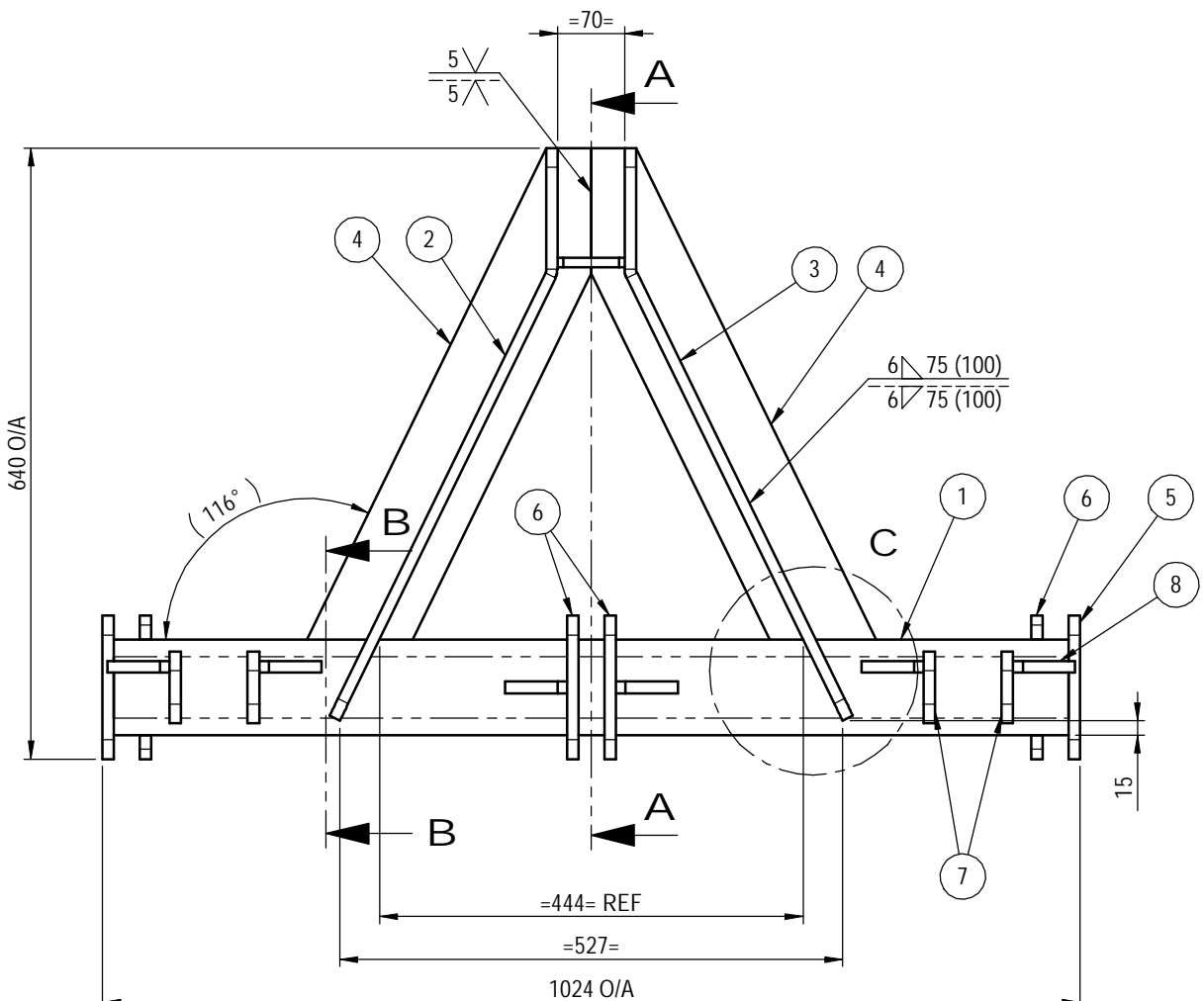
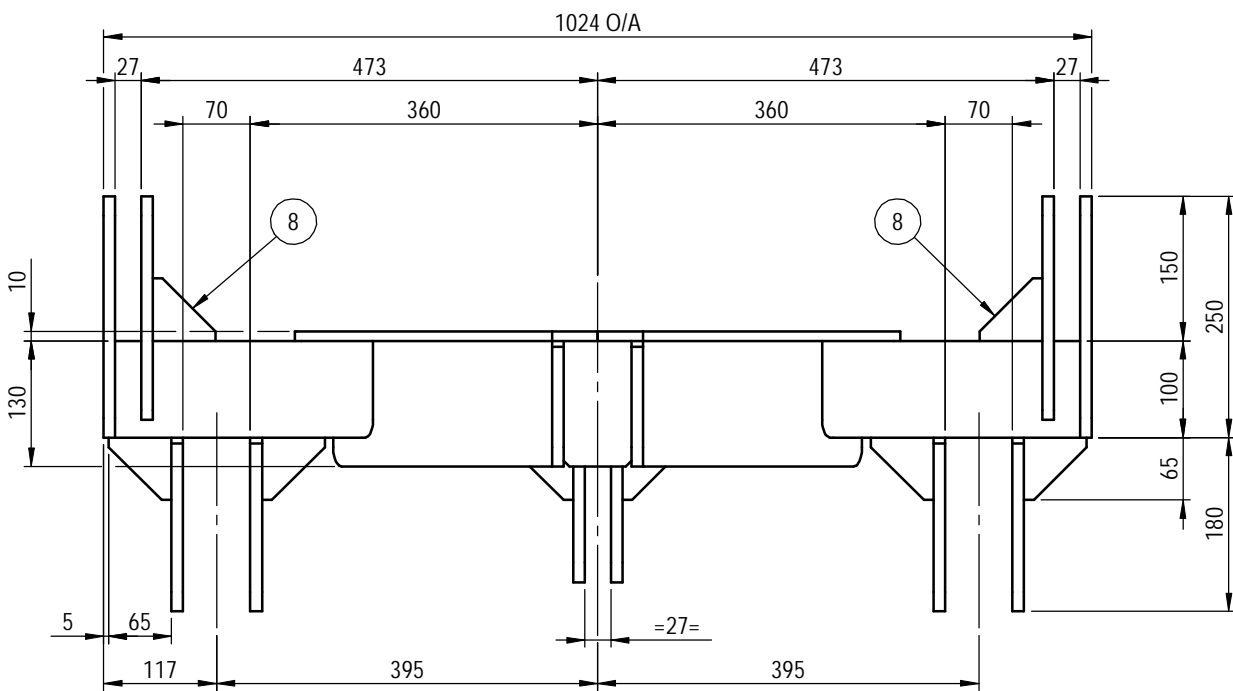

DETAIL C (1 : 5)

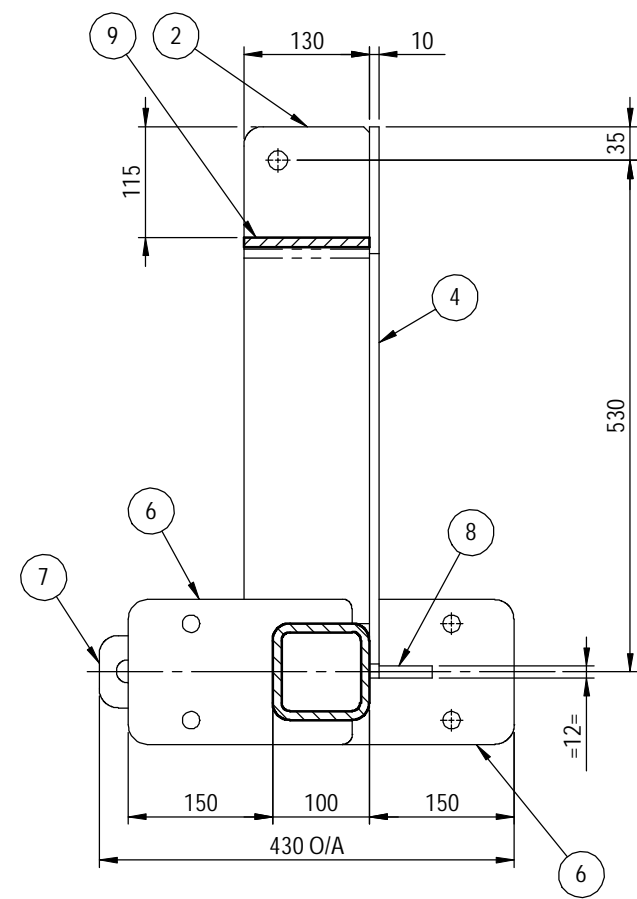

SECTION A-A

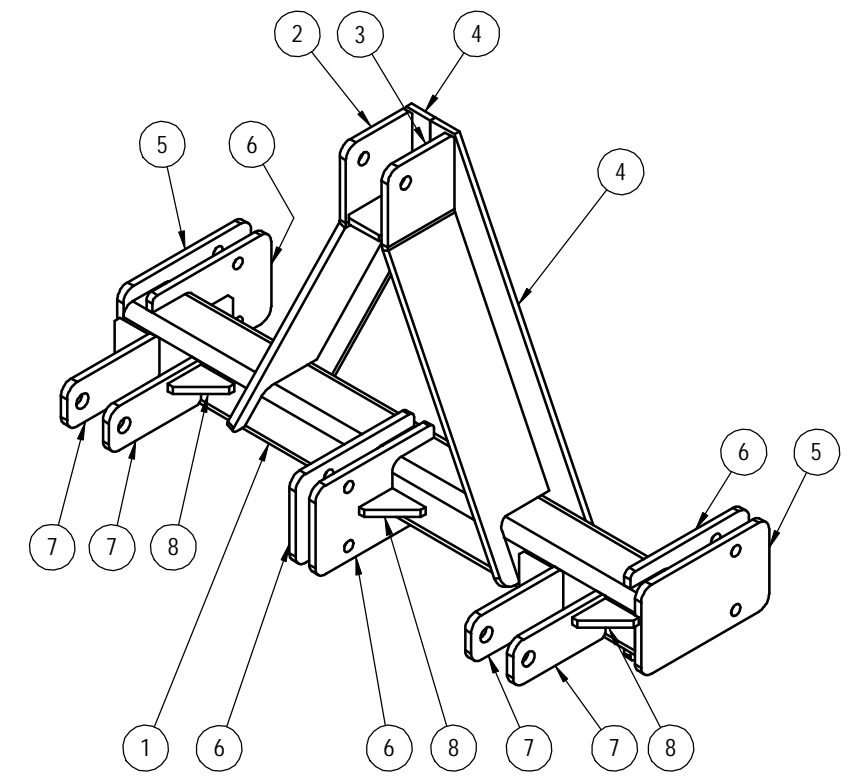

ISOMETRIC VIEW
Scale 1:10

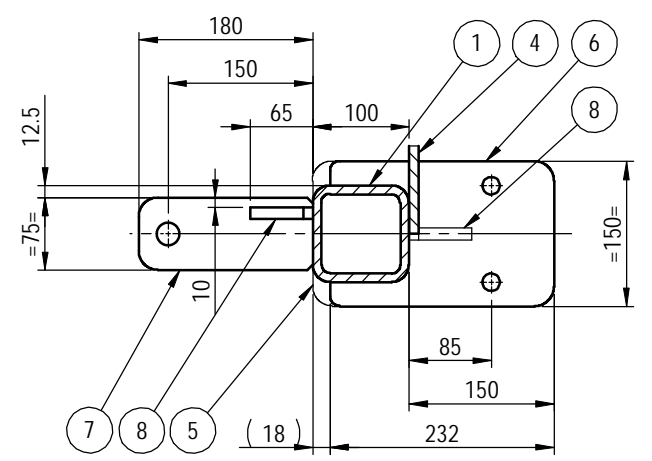

SECTION B-B

ITEM NO.	QTY.	PART NUMBER	DRAWING NUMBER	WEIGHT IN kg	DESCRIPTION
1	1	TTR001	TTR - 01	24.2	MAIN BEAM
2	1	TTR002	TTR - 02	7.1	LH HEADSTOCK UPRIGHT
3	1	TTR003	TTR - 03	7.1	RH HEADSTOCK UPRIGHT
4	2	TTR004	TTR - 04	4.6	HEADSTOCK BACK WEB
5	2	TTR005	TTR - 05	3.5	TYNE BRACKET OUTER PLATE
6	4	TTR006	TTR - 06	2.5	TYNE BRACKET INNER PLATE
7	4	TTR007	TTR - 07	1.2	3 PT LINKAGE BRACKET
8	8	TTR008	TTR - 08	0.3	GUSSET PLATE
9	1	TTR009	TTR - 09	0.7	HEADSTOCK SPACER PLATE

NOTE: ALL WELDS 6mm CFW UNO. WHERE WELDS ARE DIFFICULT TO ACCESS USE FABRICATOR'S DISCRETION.

DO NOT SCALE
IF IN DOUBT - ASK WEIGHT 72076.8 GMS

Sheet 1 of 1

No.	Description	DWN	CHK	APPD	DATE
P1	PRELIMINARY DRAWING	-	-	-	-
A	APPROVED FOR CONSTRUCTION	-	-	-	-

199 Bridge Street, Oakey, Qld, 4401

FIELDQUIP
Australia owned family business

THIS DRAWING IS PRIVATE AND CONFIDENTIAL AND REMAINS THE PROPERTY OF FIELDQUIP.
RETURNED UPON REQUEST. IT MUST NOT BE COPIED OR LOANED WITHOUT THE CONSENT OF FIELDQUIP.

SCALE	1:7.5	U.N.O
Design	D.M.	2014
Drawn	AWP	14.06.14
Check	D.M.	20.06.14
Appd.	D.M.	20.06.14

TYNE FRAME FABRICATION

THREE TYNE RIPPER

3rd ANGLE PROJECTION U.N.O.		A3
Fieldquip Drawing Number	TTR - 100	REV
		A