

ITEM NO.	QTY	PART NUMBER	DRAWING NUMBER	WEIGHT IN kg	DESCRIPTION
1	1	STR002	STR-002	18.2	LINKAGE BODY
2	1	STR001	STR-001	37.7	RIPPER BODY
3	2	STR003	STR-003	1.8	OUTER LINKAGE PLATE
4	2	STR004	STR-004	0.8	INSIDE LINKAGE PLATE
5	1	STR005	STR-005	1.2	TOP LINK PLATE LH
6	1	STR006	STR-006	1.2	TOP LINK PLATE RH
7	1	STR007	STR-007	3.8	BRACING STRAP
8	2	STR008	STR-008	1.2	RIPPER SIDE SUPPORT PLATE
9	1	STR009	STR-009	0.8	RIPPER POINT PLATE

ALL WELDS 6 CFW UNO

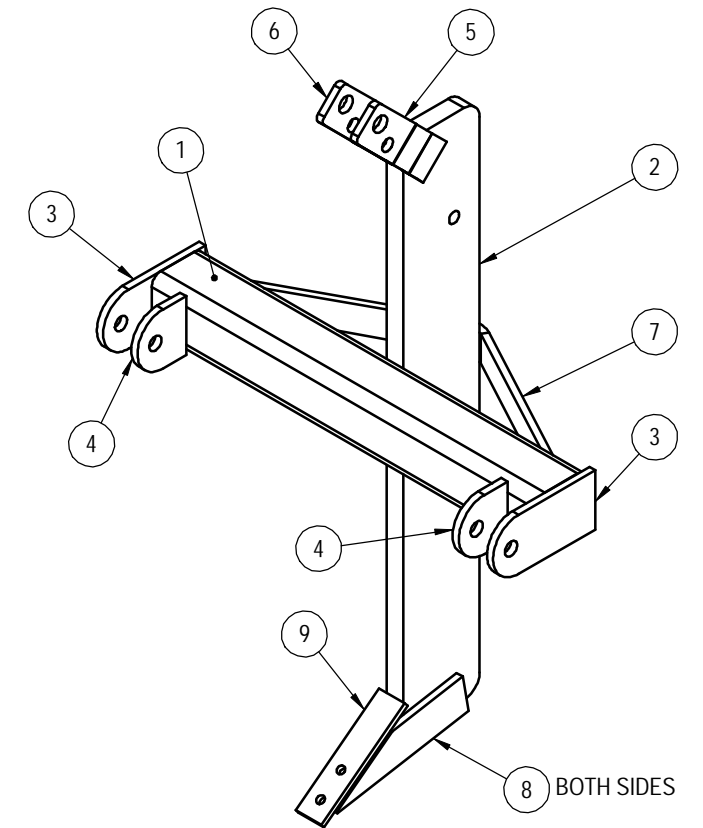

DO NOT SCALE
IF IN DOUBT - ASK WEIGHT 70394.7 GMS

Sheet 1 of 1

No.	Description	DWN	CHK	APPD	DATE
P1	PRELIMINARY DRAWING	-	-	-	-
A	APPROVED FOR CONSTRUCTION	-	-	-	-
B	GENERAL DRAWING REVIEW	AWP	D.M.	D.M.	23.01.15

199 Bridge Street, Oakey, Qld, 4401

THIS DRAWING IS PRIVATE AND CONFIDENTIAL AND REMAINS THE PROPERTY OF FIELDQUIP.
RETURNED UPON REQUEST. IT MUST NOT BE COPIED OR LOANED WITHOUT THE CONSENT OF FIELDQUIP.

SCALE	1:10	U.N.O
Design	AWP	18.10.06
Drawn	AWP	25.10.06
Check	S.M.	
Appd.	S.M.	OCT 2006

RIPPER WELDED ASSEMBLY

SINGLE TYNE RIPPER

3rd ANGLE PROJECTION U.N.O.	A3
Fieldquip Drawing Number	REV
STR-100	B