



REB SERIES TILLERS (REBEL)

MODELS REB60, REB72, REB84 REB60R, REB72R, REB84R

Published 4/16

Part No. 50075545

OPERATOR'S MANUAL



This Operator's Manual is an integral part of the safe operation of this machine and must be maintained with the unit at all times. READ, UNDERSTAND, and FOLLOW the Safety and Operation Instructions contained in this manual before operating the equipment. C01-Cover



FC-T-0007

RHINO[®]

1020 S. Sangamon Ave.
Gibson City, IL 60936
800-446-5158
Email: parts@servis-rhino.com

Rhino Web Page



www.algqr.com/rwe

¡ATENCIÓN!
LEA EL INSTRUCTIVO

Si No Lee Ingles, Pida
Ayuda a Alguien
Que Se Lo Lea Para Que le
Traduzca Las
Medidas de Seguridad

ATM MEMBER OF THE
ALAMO GROUP
ALWAYS ON THE CUTTING EDGE[®]

To the Owner/Operator/Dealer

This Operator's Manual is an integral part of the safe operation of this machine and must be maintained with the implement at all times. A Manual canister is provided on the implement where this manual can be properly stored. If you lose or damage this manual a free replacement manual can be obtained from an authorized Rhino dealer or by downloading the manual from the Rhino website www.servis-rhino.com

BEFORE YOU START! READ, UNDERSTAND, and FOLLOW the information provided in this manual, the AEM Mower Safety manual and the tractor operator's manual carefully to learn how to operate and service your machine properly. Failure to do so could result in personal injury to you and bystanders. All implements with moving parts are potentially hazardous. Every effort has been made to ensure that the machine is safe but operators must avoid engaging in unsafe practices and follow the written instructions provided. The manufacturer has designed this implement to be used with all its safety equipment properly attached to minimize the chance of accidents.

SAFETY FIRST. Completely read and understand the safety section of this manual before operating this equipment. Do not allow anyone to operate this equipment who has not fully read and understood this manual. Contact your Dealer to explain any instructions that you do not fully understand.

The care you give your Rhino Implement will greatly determine your satisfaction with its performance and its service life. Carefully read and follow the instructions in this manual to provide you with a thorough understanding of your new implement and its intended use and service requirements.

All references made in this manual to right, left, front, rear, top or bottom are as viewed facing the direction of forward travel with the implement properly attached to the tractor.

Replacement Parts information is located in a separate Parts Manual. Rhino tillers use balanced and matched system components. These parts are made and tested to Rhino specifications. Non-genuine "will fit" parts do not consistently meet these specifications. The use of "will fit" parts may reduce mower performance, void warranties, and present a safety hazard. Use genuine Rhino mower parts for economy and safety.

For future reference, record your Rhino product model number and serial number.

Dealer		Telephone		Model Number	
Owner		Purchase Date:		Serial Number	

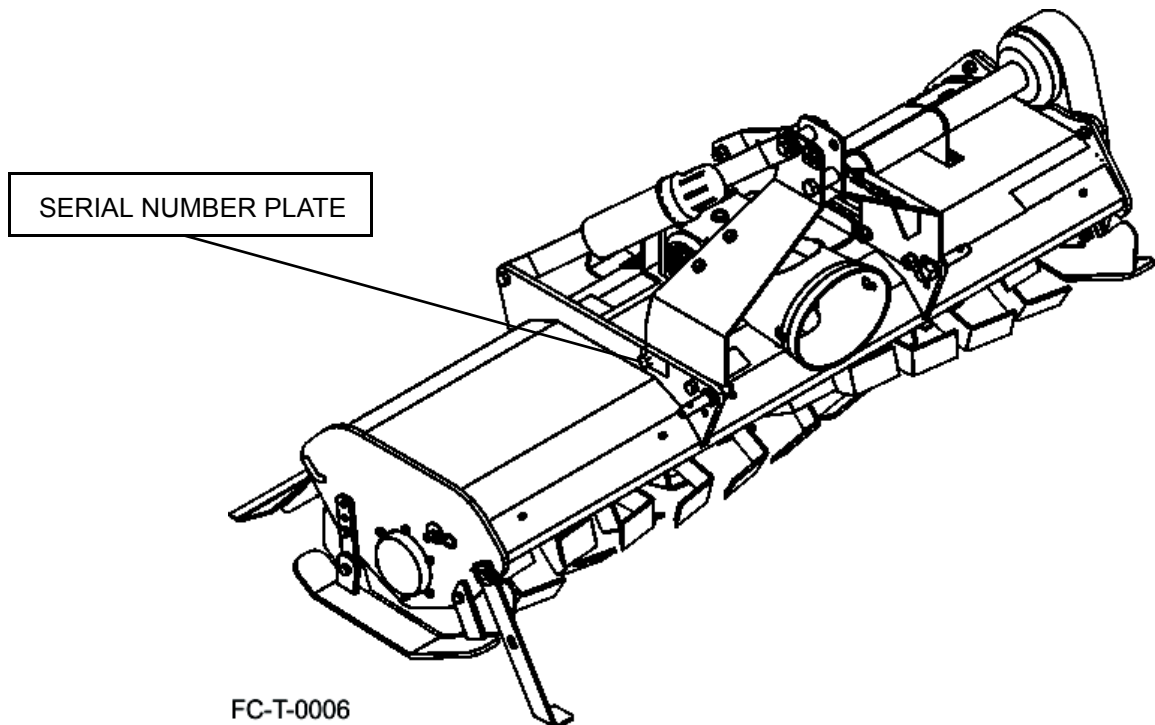

TABLE OF CONTENTS

SAFETY SECTION	1-1
General Safety Instructions and Practices	1-2
Operator Safety Instructions and Practices	1-4
Equipment Operation Safety Instructions and Practices	1-5
Transporting Safety Instructions and Practices	1-6
Maintenance and Service Safety Instructions and Practices	1-7
Storage and Parking Safety Instructions and Practices	1-10
.....	1-10
PARTS INFORMATION	1-11
Decal Location	1-12
Decal Description	1-13
Federal Laws and Regulations	1-17
INTRODUCTION SECTION	2-1
ASSEMBLY SECTION	3-1
GENERAL	3-2
REB60R, REB72R & REB84R Reverse Rotation Models ONLY	3-4
DRIVELINE ATTACHMENT	3-5
LUBRICATION	3-6
CONVERTING FROM STANDARD ROTATION TO REVERSE ROTATION	3-8
Safety First	3-8
OPERATION SECTION	4-1
Standard Equipment and Specifications	4-3
OPERATOR REQUIREMENTS	4-4
ROPS and Seat Belt	4-5
Tractor Safety Devices	4-5
Tractor Horsepower	4-6
3-Point Hitch	4-6
Front End Weight	4-6
Power Take Off (PTO)	4-6
GETTING ON AND OFF THE TRACTOR	4-7
Boarding the Tractor	4-7
Dismounting the Tractor	4-8
STARTING THE TRACTOR	4-8
CONNECTING THE IMPLEMENT TO THE TRACTOR	4-9
Connecting the Implement	4-9
Setting Implement Height	4-10
DRIVELINE ATTACHMENT	4-11
Driveline Length Check	4-11
PRE-OPERATION INSPECTION AND SERVICE	4-13
Tractor Pre-Operation Inspection/Service	4-14
Implement Pre-Operation Inspection/Service	4-14
OPERATING THE TRACTOR AND IMPLEMENT	4-17
Foreign Debris Hazards	4-17
Adjusting the Tiller for work.	4-18
Operating the Tiller	4-18

Bystanders/Passersby Precautions	4-19
Engaging the Power Take Off (PTO)	4-19
PTO RPM and Ground Speed	4-20
Shutting Down the Implement	4-20
DISCONNECTING THE IMPLEMENT FROM THE TRACTOR	4-21
IMPLEMENT STORAGE	4-22
TRANSPORTING THE TRACTOR AND IMPLEMENT	4-22
DRIVING THE TRACTOR AND IMPLEMENT	4-22
Brake and Differential Lock Setting	4-24
Transporting on Public Roadways	4-25
Hauling the Tractor and Implement	4-26
TROUBLESHOOTING GUIDE	4-28

MAINTENANCE SECTION 5-1

LUBRICATION INFORMATION	5-2
Outboard Bearing Lubrication	5-2
LUBRICATION	5-2
DRIVESHAFT LUBRICATION	5-4
SLIP CLUTCHES	5-5
SEASONAL CLUTCH MAINTENANCE	5-5
GENERAL MAINTENANCE	5-6
Blades	5-6
Fasteners	5-6
Safety Devices	5-6
STORAGE	5-6
PROPER TORQUE FOR FASTENERS	5-6

SAFETY SECTION

SAFETY

General Safety Instructions and Practices

A careful operator is the best operator. Safety is of primary importance to the manufacturer and should be to the owner/operator. Most accidents can be avoided by being aware of your equipment, your surroundings, and observing certain precautions. The first section of this manual includes a list of Safety Messages that, if followed, will help protect the operator and bystanders from injury or death. Read and understand these Safety Messages before assembling, operating or servicing this Implement. This equipment should only be operated by those persons who have read the manual, who are responsible and trained, and who know how to do so responsibly.



The Safety Alert Symbol combined with a Signal Word, as seen below, is used throughout this manual and on decals which are attached to the equipment. The Safety Alert Symbol means: "ATTENTION! BECOME ALERT! YOUR SAFETY IS INVOLVED!" The Symbol and Signal Word are intended to warn the owner/operator of impending hazards and the degree of possible injury faced when operating this equipment.

Practice all usual and customary safe working precautions and above all--remember safety is up to YOU. Only YOU can prevent serious injury or death from unsafe practices.



Indicates an imminently hazardous situation that, if not avoided, WILL result in DEATH OR VERY SERIOUS INJURY.



Indicates an imminently hazardous situation that, if not avoided, COULD result in DEATH OR SERIOUS INJURY.



Indicates an imminently hazardous situation that, if not avoided, MAY result in MINOR INJURY.



Identifies special instructions or procedures that, if not strictly observed, could result in damage to, or destruction of the machine, attachments or the environment.

NOTE: *Identifies points of particular interest for more efficient and convenient operation or repair.* (SG-1)

READ, UNDERSTAND, and FOLLOW the following Safety Messages. Serious injury or death may occur unless care is taken to follow the warnings and instructions stated in the Safety Messages. Always use good common sense to avoid hazards. (SG-2)



Always maintain the safety signs in good readable condition. If the safety signs are missing, damaged, or unreadable, obtain and install replacement safety signs immediately. (SG-5)

SAFETY

DANGER

Never operate the Tractor or Implement until you have read and completely understand this Manual, the Tractor Operator's Manual, and each of the Safety Messages found in the Manual or on the Tractor and Implement. Learn how to stop the tractor engine suddenly in an emergency. Never allow inexperienced or untrained personnel to operate the Tractor or Implement without supervision. Make sure the operator has fully read and understood the manuals prior to operation.

(SG-4)

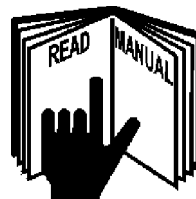

WARNING

Operate this Equipment only with a Tractor equipped with an approved roll-over-protective system (ROPS). Always wear seat belts. Serious injury or even death could result from falling off the tractor--particularly during a turnover when the operator could be pinned under the ROPS. (SG-7)



DANGER

BEFORE leaving the tractor seat lower the implement, set the parking brake and/or set the tractor transmission in parking gear, disengage the PTO, stop the engine, remove the key, and wait for all moving parts to stop. Place the tractor shift lever into a low range or parking gear to prevent the tractor from rolling. Never dismount a Tractor that is moving or while the engine is running. Operate the Tractor controls from the tractor seat only. (SG-9)

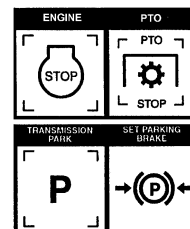

DANGER

Never allow children or other persons to ride on the Tractor or Implement. Falling off can result in serious injury or death. (SG-10)



DANGER

Never allow children to operate, ride on, or come close to the Tractor or Implement. Usually, 16-17 year-old children who are mature and responsible can operate the implement with adult supervision, if they have read and understand the Operator's Manuals, been trained in proper operation of the tractor and Implement, and are physically large enough to reach and operate the controls easily. (SG-11)



WARNING

Do not mount or dismount the Tractor while the tractor is moving. Mount the Tractor only when the Tractor and all moving parts are completely stopped. (SG-12)



WARNING

Do not modify or alter this Implement. Do not permit anyone to modify or alter this Implement, any of its components or any Implement function. (SG-8)

SAFETY

SAFETY

Operator Safety Instructions and Practices

WARNING

The operator and all support personnel should wear hard hats, safety shoes, safety glasses, and proper hearing protection at all times for protection from injury including injury from items that may be thrown by the equipment. (SG-16)



CAUTION

PROLONGED EXPOSURE TO LOUD NOISE MAY CAUSE PERMANENT HEARING LOSS! Tractors with or without an Implement attached can often be noisy enough to cause permanent hearing loss. We recommend that you always wear hearing protection if the noise in the Operator's position exceeds 80db. Noise over 85db over an extended period of time will cause severe hearing loss. Noise over 90db adjacent to the Operator over an extended period of time will cause permanent or total hearing loss. **NOTE:** *Hearing loss from loud noise [from tractors, chain saws, radios, and other such sources close to the ear] is cumulative over a lifetime without hope of natural recovery.* (SG-17)



WARNING

Always read carefully and comply fully with the manufacturer's instructions when handling oil, solvents, cleansers, and any other chemical agent. (SG-22)



DANGER

KEEP AWAY FROM ROTATING ELEMENTS to prevent entanglement and possible serious injury or death. (SG-24)



DANGER

Never allow children to play on or around Tractor or Implement. Children can slip or fall off the Equipment and be injured or killed. Inadvertent contact with controls can cause the Implement to shift or fall crushing themselves or others. (SG-25)

WARNING

Be sure you have adequate knowledge of the property you will be working on. Take time to make yourself aware of any area underwater or underground lines or cables. Contact with buried lines or cable could result in serious injury or death. (STL-1)

DANGER

Do not put hands or feet under Tiller deck. Blade Contact can result in serious injury or even death. Stay away until all motion has stopped and the decks are securely blocked up. (STL-3)

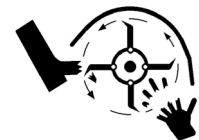

SAFETY



WARNING Extreme care should be taken when operating near loose objects such as gravel, rocks, wire, and other debris. Inspect the area before tilling. Foreign objects should be removed from the site to prevent machine damage and/or bodily injury or even death. Any objects that cannot be removed must be clearly marked and carefully avoided by the operator. Stop operating immediately if blades strike a foreign object. Repair all damage and make certain rotor and blades are in good condition before resuming operation. (STL-5)

Equipment Operation Safety Instructions and Practices



DANGER DO NOT use drugs or alcohol immediately before or while operating the Tractor and Implement. Drugs and alcohol will affect an operator's alertness and coordination and therefore affect the operator's ability to operate the equipment safely. Before operating the Tractor or Implement, an operator on prescription or over-the-counter medication must consult a medical professional regarding any side effects of the medication that would hinder their ability to operate the Equipment safely. NEVER knowingly allow anyone to operate this equipment when their alertness or coordination is impaired. Serious injury or death to the operator or others could result if the operator is under the influence of drugs or alcohol. (SG-27)



SAFETY



DANGER Operate the Tractor and/or Implement controls only while properly seated in the Tractor seat with the seat belt securely fastened around you. Inadvertent movement of the Tractor or Implement may cause serious injury or death. (SG-29)



DANGER Do not operate the implement while wearing loose fitting clothing. Entanglement of the clothing with the rotating elements can result in serious injury or even death. Stay clear of all rotating elements at all times. (SSP-03)



DANGER Start tractor only when properly seated in the Tractor seat. Starting a tractor in gear can result in injury or death. Read the Tractor operators manual for proper starting instructions. (SG-13)



DANGER Never run the Tractor engine in a closed building or without adequate ventilation. The exhaust fumes can be hazardous to your health. (SG-23)



WARNING Do not exceed the rated PTO speed for the Implement. Excessive PTO speeds can cause Implement driveline or blade failures resulting in serious injury or death. (SG-26)

SAFETY

DANGER

Operate the Tractor and/or Implement controls only while properly seated in the Tractor seat with the seat belt securely fastened around you. Inadvertent movement of the Tractor or Implement may cause serious injury or death. (SG-29)

DANGER

There are obvious and hidden potential hazards in the operation of this Implement as in all power-driven or pulled equipment. REMEMBER! This machine is often operated in rough terrain conditions that include grass, weeds, gullies, holes, slopes, hidden obstructions and the like. Serious injury or even death may occur unless care is taken to assure the safety of the operator and bystanders in the area. Do not operate this machine with anyone in the immediate area. Stop operating if anyone comes within 25 feet of the equipment. (STL-4)

WARNING

Many varied objects, such as wire, cable, rope, or chains, can become entangled in the rotating parts of the Implement. These objects could then swing outside the housing at greater velocities than the blades. Such a situation is extremely hazardous and could result in serious injury or even death. Inspect the area for such objects before working in the area. Remove any such objects from the site. Never allow the implement to contact such objects. (STL-6)

Transporting Safety Instructions and Practices

DANGER

This Implement may be wider than the Tractor. Be careful when operating or transporting this equipment to prevent the Implement from running into or striking sign posts, guard rails, concrete abutments or other solid objects. Such an impact could cause the Implement and Tractor to pivot violently resulting in loss of steering control, serious injury, or even death. Never allow the Implement to contact obstacles. (S3PT-12)

WARNING

Be particularly careful when transporting the Implement with the Tractor. Turn curves or go up hills only at a low speed and using a gradual steering angle. Rear mounted implements move the center of gravity to the rear and remove weight from the front wheels. Make certain, by adding front ballast, that at least 20% of the tractor's weight is on the front wheels to prevent rearing up, loss of steering control or Tractor tip-over. Slow down on rough or uneven surfaces to prevent loss of steering control which could result in property damage or possible injury. Do not transport unless 3-Point lift lever is fully raised and in the latched transport position. Dropping implement in transport can cause serious damage to the tractor and/or Implement and possibly cause the operator or others to be injured or killed. (S3PT-02)

SAFETY

Maintenance and Service Safety Instructions and Practices



The rotating parts of this machine continue to rotate even after the PTO has been turned off. The operator should remain in the operator's seat for 60 seconds after the brake has been set, the PTO disengaged, the tractor turned off, and all evidence of rotation has ceased. (S3PT-10)

“Wait a minute...Save a life!”



Never crawl under a raised Implement supported solely by the Tractor 3-Point hitch. Release of the control lever or mechanical failure will result in the Implement falling and possible injury or death. Always securely block up the Implement before crawling underneath to perform repairs and service. (S3PT-19)



Do not operate this Equipment with hydraulic oil or fuel leaking. Oil and fuel are explosive and their presence could present a hazard. Do not check for leaks with your hand! High-pressure oil streams from breaks in the line could penetrate the skin and cause tissue damage including gangrene. To check for a hose leak, SHUT the unit ENGINE OFF and remove all hydraulic pressure. Wear oil impenetrable gloves, safety glasses and use Cardboard to check for evidence of oil leaks. If you suspect a leak, REMOVE the HOSE and have it tested at a Dealer. If oil does penetrate the skin, have the injury treated immediately by a physician knowledgeable and skilled in this procedure. (SG-15)



Make sure the PTO shield, integral driveline shields, and input shields are installed when using PTO-driven equipment. Always replace any shield if it is damaged or missing. (S3PT-8)



Relieve hydraulic pressure prior to doing any maintenance or repair work on the Implement. Place the Implement on the ground or securely blocked up, disengage the PTO, and turn off the tractor engine. Push and pull the Remote Cylinder lever in and out several times prior to starting any maintenance or repair work. (S3PT-09)



Always disconnect the main PTO Driveline from the Tractor before performing service on the Implement. Never work on the Implement with the tractor PTO driveline connected and running. Rotating Parts, Blades or Drivelines could turn without warning and cause immediate entanglement, injury or death. (S3PT-11)



Always maintain the safety signs in good readable condition. If the safety signs are missing, damaged, or unreadable, obtain and install replacement safety signs immediately. (SG-5)

SAFETY

⚠ DANGER

Never work under the Implement, the framework, or any lifted component unless the Implement is securely supported or blocked up to prevent sudden or inadvertent falling which could cause serious injury or even death. (SG-14)



⚠ WARNING

Never attempt to lubricate, adjust, or remove material from the Implement while it is in motion or while tractor engine is running. (SG-20)

⚠ WARNING

Periodically inspect all moving parts for wear and replace when necessary with authorized service parts. Look for loose fasteners, worn or broken parts, and leaky or loose fittings. Make sure all pins have cotter pins and washers. Serious injury may occur from not maintaining this machine in good working order. (SG-21)

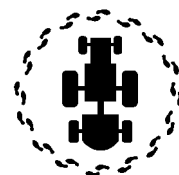

⚠ WARNING

Perform service, repairs and lubrication according to the maintenance section. Ensure the unit is properly lubricated as specified in the lubrication schedule and all bolts and nuts are properly torqued. Failure to properly service, repair and maintain this Implement in good operating condition could cause component failure and possible serious injury or even death. (SG-35)

⚠ WARNING

Use caution and wear protective gloves when handling sharp objects such as blades, knives, and other cutting edges. Be alert to worn component surfaces which have sharp edges. Sharp surfaces can inflict severe laceration injuries if proper hand protection is not worn. (SG-37)

PARTS INFORMATION

Rhino products are designed utilizing specifically matched system components to ensure optimum equipment performance. These parts are made and tested to Rhino specifications. Non-genuine "will fit" parts do not consistently meet these specifications. The use of "will fit" parts may reduce equipment performance, void warranties, and present a safety hazard. Use genuine Rhino parts for economy and safety. (SPRM-2)

SEE YOUR RHINO DEALER

SAFETY



Transport only at speeds where you can maintain control of the equipment. Serious accidents and injuries can result from operating this equipment at high speeds. Understand the Tractor and Implement and how it handles before transporting on streets and highways. Make sure the Tractor steering and brakes are in good condition and operate properly.



Before transporting the Tractor and Implement, determine the proper transport speeds for you and the equipment. Make sure you abide by the following rules:

Test the tractor at a slow speed and increase the speed slowly. Apply the Brakes smoothly to determine the stopping characteristics of the Tractor and Implement. As you increase the speed of the Tractor the stopping distance increases. Determine the maximum transport speed not to exceed 20 mph (30 kph) for transporting this equipment.

Test the equipment at a slow speed in turns. Increase the speed through the turn only after you determine that the equipment can be operated at a higher speed. Use extreme care and reduce your speed when turning sharply to prevent the tractor and implement from turning over. Determine the maximum turning speed for you and this equipment before operating on roads or uneven ground.



Only transport the Tractor and Implement at the speeds which allow you to properly control the equipment.

Be aware of the operating conditions. Do not operate the Tractor with weak or faulty brakes or worn tires. When operating down a hill or on wet or rain slick roads, the braking distance increases: use extreme care and reduce your speed. When operating in traffic always use the Tractor's flashing warning lights and reduce your speed. Be aware of traffic around you and watch out for the other guy. (SG-19)



Only tow the Implement behind a properly sized and equipped Tractor which exceeds the weight of the Implement by at least 20%. DO NOT tow the Implement behind a truck or other type of vehicle. Never tow the Implement and another Implement connected in tandem. Never tow the Implement at speeds over 20 MPH. (STI-06)



Your driving vision may be reduced or impaired by the tractor, cab, or implement. Before driving on public roadways identify any limited vision areas, and make adjustments to your operating position, mirrors, and the implement transport position so that you can clearly see the area where you will be traveling, and any traffic that may approach you. Failure to maintain adequate vision of the public roadway and traffic can result in serious injury or even death. (STI-10)



Make certain that the "Slow Moving Vehicle" (SMV) sign is installed in such a way as to be clearly visible and legible. When transporting the Equipment use the Tractor flashing warning lights and follow all local traffic regulations. (SG-6)

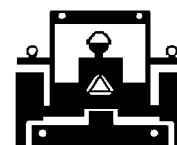

SAFETY

SAFETY



WARNING In wet conditions where there is a likelihood of material collecting on the Implement, make certain that this material is removed before traveling on public roadways. (STL-7)

Storage and Parking Safety Instructions and Practices



WARNING Never leave the Tractor and Implement unattended while the Implement is in the lifted position. Accidental operation of lifting lever or a hydraulic failure may cause sudden drop of unit with injury or death by crushing. To properly park the implement when disconnecting it from the tractor, lower the stand and put the retaining pin securely in place, or put a secure support under the A-Frame. Lower the implement carefully to the ground. Do not put hands or feet under lifted components. (S3PT-1)



DANGER Always shut the Tractor completely down, place the transmission in park, and set the parking brake before you or anyone else attempts to connect or disconnect the Implement and Tractor hitches. (S3PT-15)



CAUTION To prevent tipping of Implement when stored in folded position, use carrying wheels or adequate stands on center frame. (S3PT-6)

SAFETY

PARTS INFORMATION

PARTS INFORMATION

Rhino mowers use balanced and matched system components for blade carriers, blades, cuttershafts, knives, knife hangers, rollers, drivetrain components, and bearings. These parts are made and tested to Rhino specifications. Non-genuine "will fit" parts do not consistently meet these specifications. The use of "will fit" parts may reduce mower performance, void warranties, and present a safety hazard. Use genuine Rhino mower parts for economy and safety. (SPRM-1)

SEE YOUR RHINO DEALER

Operator's & Parts Manuals



www.algqr.com/rpm

In addition to the design and configuration of this Implement, including Safety Signs and Safety Equipment, hazard control and accident prevention are dependent upon the awareness, concern, prudence, and proper training of personnel involved in the operation, transport, maintenance, and storage of the machine. Refer also to Safety Messages and operation instruction in each of the appropriate sections of the Tractor and Equipment Manuals. Pay close attention to the Safety Signs affixed to the Tractor and Equipment. (SG-18)

SAFETY

SAFETY

Decal Location

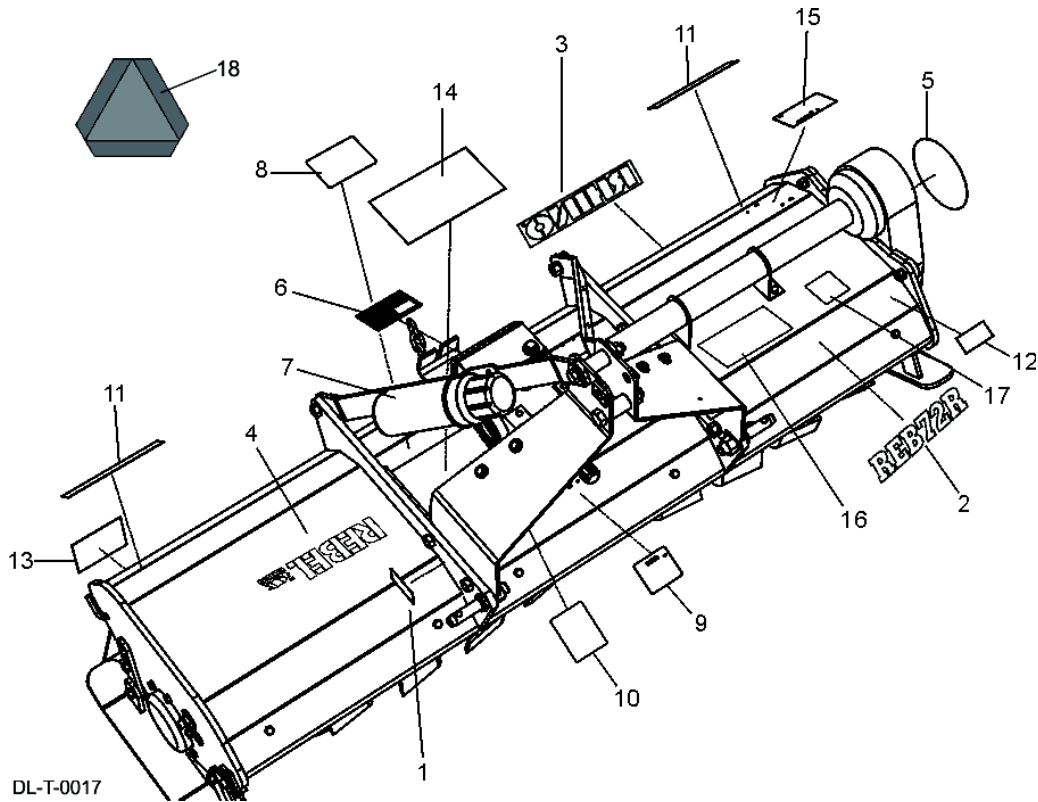

DL-T-0017

ITEM	PART NO.	QTY	TYPE	DESCRIPTION
1.	NFS	1	SERIAL PLT	Serial Number Plate
2.	50075539	1	MODEL	REB60
	50075537	1	MODEL	REB60R
	50075536	1	MODEL	REB72
	50075538	1	MODEL	REB72R
	50075818	1	MODEL	REB84
	50075819	1	MODEL	REB84R
3.	50074662	1	LOGO	Rhino Logo
4.	50075534	1	LOGO	REBEL Series
5.	50075533	1	LOGO	Rhino Tiller Gear
6.	50074259	1	FLAG	Made in the USA
7.	50035829	1	-----	Manual Canister
	50075545	1	-----	Operator's Manual
8.	D880	1	WARNING	Genuine Rhino Parts
9.	D546	1	DANGER	Guard Missing
10.	D547	1	CAUTION	Operate at 540 RPM
11.	50031214	2	REFLECT	Red Reflector
12.	50031212	1	REFLECT	Amber Reflector
13.	81067	1	DANGER	Keep Away Rotating Tines
14.	78413	1	WARNING	Read Manual
15.	D628	1	DANGER	Crushing Hazard/Pinch Points
16.	D830	1	DANGER	Multi-Language
17.	D898	1	DANGER	Thrown Objects (Reverse Series)
18.	03200347	1	REFLECT	SMV Sign

SAFETY

SAFETY

Decal Description

! WARNING

**Non-genuine parts can fail catastrophically.
TO AVOID SERIOUS INJURY OR DEATH:**

- ONLY use genuine RHINO replacement parts.
- Non-genuine parts can fail creating hazardous conditions for operator and bystanders.

Contact local dealer or RHINO about repair parts at:
1020 S. Sangamon Ave.,
Gibson City, IL 60936
Customer Service: 800-446-5158.
Email: parts@servis-rhino.com



www.algqr.com/rpm

D880

! DANGER

D546



**GUARD MISSING
DO NOT OPERATE**

D546 B

! DANGER



KEEP AWAY FROM ROTATING TINES.

**ROTATING TINES WILL CAUSE
SERIOUS INJURY OR DEATH.**

81067

SAFETY

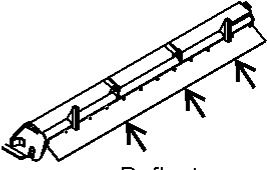

SAFETY

⚠ DANGER		
		
TO AVOID SERIOUS INJURY OR DEATH FROM DRIVELINE CONTACT, DRIVELINE SEPARATION OR PTO STUB SHAFT FAILURE:		
<ul style="list-style-type: none">• STOP, LOOK and LISTEN for rotating motion before approaching implement.• STAY AWAY and KEEP hands, feet and body AWAY from rotating parts until all moving elements have stopped.• ALWAYS shut off PTO before dismounting.• DO NOT operate if PTO shields are damaged or missing.• PUSH AND PULL on yoke until collar clicks and locks yoke in place.• CHECK driveline guards for free rotation and sufficient overlap to avoid unshielded areas.• DO NOT USE PTO ADAPTER		
		
⚠ WARNING		
OPERATE THIS MACHINE AT 540 RPM TRACTOR PTO SPEED ONLY. Overspeeding PTO may cause component failure resulting in bodily injury. TRACTOR PTO ROTATION: CLOCKWISE	 D547	

⚠ DANGER	
THROWN OBJECT HAZARD	
TO AVOID SERIOUS INJURY OR DEATH: DO NOT OPERATE if Thrown Object Shielding is damaged or missing.	
<ul style="list-style-type: none">• Maintain Deflectors in good condition.• Inspect Deflectors frequently.	
MAINTAIN Thrown Object Shielding HERE	 D898

SAFETY

 **WARNING**



TO AVOID SERIOUS INJURY OR DEATH:

- READ OPERATOR'S MANUAL BEFORE OPERATING AND FOLLOW ALL PRECAUTIONS. (CONTACT DEALER FOR MANUAL)
- KEEP SHIELDS AND GUARDS IN PLACE. KEEP CLEAR OF DRIVES AND BELTS.
- LOWER IMPLEMENT, STOP ENGINE AND PTO, ALLOW ALL MOVING PARTS TO STOP, AND REMOVE KEY BEFORE DISMOUNTING FROM TRACTOR.
- KEEP HANDS, FEET AND CLOTHING AWAY FROM POWER DRIVEN PARTS.
- ALLOW NO CHILDREN OR UNQUALIFIED PERSONS TO OPERATE EQUIPMENT.
- BE CAREFUL ON UNEVEN TERRAIN. DECREASE SPEED WHEN TURNING.
- DO NOT OPERATE IN TRANSPORT POSITION.
- OPERATE ONLY AT SAFE DISTANCE FROM BYSTANDERS.

78413

 **DANGER**

CRUSHING HAZARD AND PINCH POINTS



TO AVOID SERIOUS INJURY OR DEATH:

- KEEP AWAY from moving machinery parts that can pinch, crush or fall.

D628





SAFETY

SAFETY

SAFETY

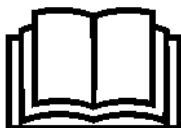
! PELIGRO	! DANGER
Si no puede leer inglés: antes de poner en funcionamiento este equipo, solicite que alguien le traduzca los mensajes de seguridad o vaya al sitio web para consultar los mensajes de seguridad y las etiquetas ya traducidos.	Si vous ne savez pas lire le français: avant d'utiliser l'équipement, demandez à une personne de vous traduire les messages de sécurité ou allez sur le site Internet pour voir la traduction des autocollants et des messages de sécurité.
El Manual del Operador Seguridad vídeo	Manuel de l'Opérateur
 	 
www.algqr.com/rfs	www.algqr.com/rff

D830_1

! PERIGO	! GEFAHR
Caso você não leia inglês: antes de operar o equipamento, peça para alguém traduzir as mensagens de segurança ou visite a web e obtenha tais mensagens ou os decalques traduzidos.	Falls Sie Deutsch nicht lesen können: Lassen Sie sich, bevor Sie das Gerät in Betrieb nehmen, die Sicherheitshinweise von einer geeigneten Person in Ihre Sprache übersetzen. Oder suchen Sie auf unserer Website nach Übersetzungen von Schilderaufschriften und Sicherheitshinweisen.
Manual do Operador	Benutzerhandbuch
 	 
www.algqr.com/rfp	www.algqr.com/rfg

D830_2

SAFETY

Federal Laws and Regulations

This section is intended to explain in broad terms the concept and effect of federal laws and regulations concerning employer and employee equipment operators. This section is not intended as a legal interpretation of the law and should not be considered as such.

Employer-Employee Operator Regulations

U.S. Public Law 91-596 (The Williams-Steiger Occupational and Health Act of 1970) OSHA

This Act Seeks:

"...to assure so far as possible every working man and woman in the nation safe and healthful working conditions and to preserve our human resources..."

DUTIES

Sec. 5 (a) Each employer-

- (1) shall furnish to each of his employees employment and a place of employment which are free from recognized hazards that are causing or are likely to cause death or serious physical harm to his employees;
- (2) shall comply with occupational safety and health standards promulgated under this Act.
- (b) Each employee shall comply with occupational safety and health standards and all rules, regulations and orders issued pursuant to this Act which are applicable to his own actions and conduct.

OSHA Training Requirements

Title 29, Code of Federal Regulations Part 1928.57(a)(6). www.osha.gov

Operator instructions. At the time of initial assignment and at least annually thereafter, the employer shall instruct every employee who operates an agricultural tractor and implements in the safe operating practices and servicing of equipment with which they are or will be involved, and of any other practices dictated by the work environment.

Keep all guards in place when the machine is in operation;

Permit no riders on equipment

Stop engine, disconnect the power source, and wait for all machine movement to stop before servicing, adjusting, cleaning or unclogging the equipment, except where the machine must be running to be properly serviced or maintained, in which case the employer shall instruct employees as to all steps and procedures which are necessary to safely service or maintain the equipment.

Make sure everyone is clear of machinery before starting the engine, engaging power, or operating the machine.

Employer Responsibilities:

To ensure employee safety during Tractor and Implement operation, it is the employer's responsibility to:

1. Train the employee in the proper and safe operation of the Tractor and Implement.
2. Require that the employee read and fully understand the Tractor and Implement Operator's manual.
3. Permit only qualified and properly trained employees to operate the Tractor and Implement.
4. Maintain the Tractor and Implement in a safe operational condition and maintain all shields and guards on the equipment.
5. Ensure the Tractor is equipped with a functional ROPS and seat belt and require that the employee operator securely fasten the safety belt and operate with the ROPS in the raised position at all times.
6. Forbid the employee operator to carry additional riders on the Tractor or Implement.
7. Provide the required tools to maintain the Tractor and Implement in a good safe working condition and provide the necessary support devices to secure the equipment safely while performing repairs and service.
8. Require that the employee operator stop operation if bystanders or passersby come within 300 feet.

Child Labor Under 16 Years of Age

INTRODUCTION SECTION

INTRODUCTION

These Tillers are designed with care and built with quality materials by skilled workers. Proper assembly, maintenance, and operating practices, as described in this manual, will help the owner/operator get years of satisfactory service from the machine.

The purpose of this manual is to familiarize, instruct. The Assembly Section instructs the owner/operator in the correct assembly of the Tiller using standard and optional equipment.

Careful use and timely service save extensive repairs and costly downtime losses. The Operation and Maintenance Sections of the manual train the owner/operator how to work the Tiller correctly and attend to appropriate maintenance. The Trouble Shooting Guide helps diagnose difficulties with Tiller and offers solution to the problems.

Safety is of primary importance to the owner/operator and to the manufacturer. The first section of this manual includes a list of Safety Messages, that, if followed, will help protect the operator and bystanders from injury or death. Many of the Safety Messages will be repeated throughout the manual. The owner/operator/dealer should know these Safety Messages before assembly and be aware of the hazards of operating this Tiller during assembly, use, and maintenance. The Safety Alert Symbol combined with a Signal Word, as seen below, is intended to warn the owner/operator of impending hazards and the degree of possible injury faced when operating this machine.



Indicates an imminently hazardous situation that, if not avoided, WILL result in DEATH OR VERY SERIOUS INJURY.



Indicates an imminently hazardous situation that, if not avoided, COULD result in DEATH OR SERIOUS INJURY.



Indicates an imminently hazardous situation that, if not avoided, MAY result in MINOR INJURY.



For Non-Agricultural use, OSHA, ASAE, SAE, and ANSI standards require the use of Chain Guards, Deflectors, or Solid Skirts at all times. The implement manufacturer strongly recommends the use of Chain Guards or Rubber Deflectors for Agricultural purposes as well, to reduce the risk of property damage, serious bodily injury, or even death from objects thrown out by or from contact with the Cutting Blades.

INTRODUCTION

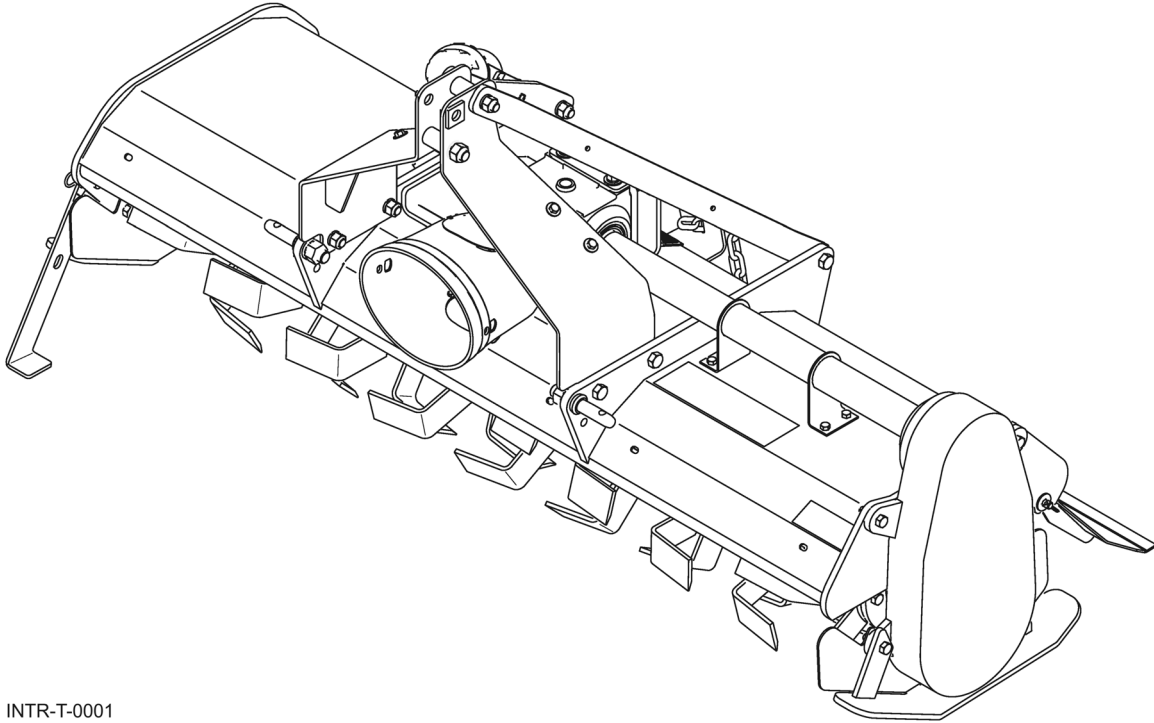

INTR-T-0001

INTRODUCTION

The REB60 requires between 25HP - 45 HP with adequate front end weight.

The REB60R requires between 25HP - 45 HP with adequate front end weight.

The REB72 requires between 35 HP - 55 HP with adequate front end weight.

The REB72R requires between 35 HP - 55 HP with adequate front end weight.

The REB84 requires between 45 HP - 65 HP with adequate front end weight.

The REB84R requires between 45 HP - 65HP with adequate front end weight.

Literature Page



www.algqr.com/rle



At least 20% of the tractor's total weight must be on the front tires with the implement lifted to provide adequate traction at safe steering under good conditions. Slow down on hills, rough terrain and curves.

Front and rear, and left and right are determined by the normal direction of travel (the same as on your automobile).

Carefully read the Operator's Manual completely, understand the Safety Messages and instructions, and know how to operate correctly both the tractor and tiller.

INTRODUCTION

Attention Owner/Operator

BEFORE OPERATING THIS MACHINE:

1. Carefully read the Operator's Manual, completely understand the Safety Messages and instructions, and know how to operate correctly both the tractor and implement.
2. Fill out the Warranty Card in full. Be sure to answer all questions, including the Serial Number of the implement.

NOTE: Warranties are honored only if completed "Owner Registration and Warranty" forms are received by Alamo Group within thirty days of delivery of the implement.

3. Record the Tiller Model and Serial Numbers on the Warranty page at the front of the Operator's Manual. Keep this as part of the permanent maintenance file for the implement.

 **WARNING**

**Non-genuine parts can fail catastrophically.
TO AVOID SERIOUS INJURY OR DEATH:**

- ONLY use genuine RHINO replacement parts.
- Non-genuine parts can fail creating hazardous conditions for operator and bystanders.

Contact local dealer or RHINO about repair parts at:
1020 S. Sangamon Ave.,
Gibson City, IL 60936
Customer Service: 800-446-5158.
Email: parts@servis-rhino.com

www.algqr.com/rpm
D880

ASSEMBLY SECTION

ASSEMBLY

GENERAL

Rhino REBEL Series Tillers are shipped from the factor partially assembled in a shipping crate and requires some assembly before being placed into service.

Follow these instructions listed to safely remove the tiller from the shipping crate and prepare for assembly.

1. With the tiller still in the shipping crate, place it on a hard level surface.
2. Remove the crating top and sides and discard.
3. Remove the driveshaft from the shipping assembly and lay aside for installation later.
4. Insert a lifting strap in the gearbox mounting frame.

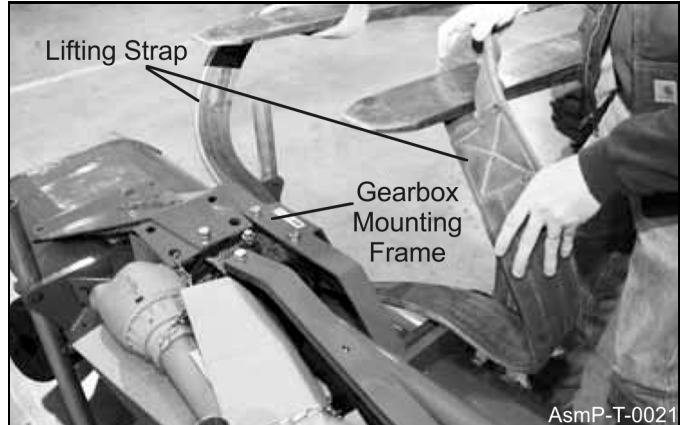

5. Carefully lift the tiller assembly from the shipping pallet.
6. Remove parking stand from storage position and place in parking position.

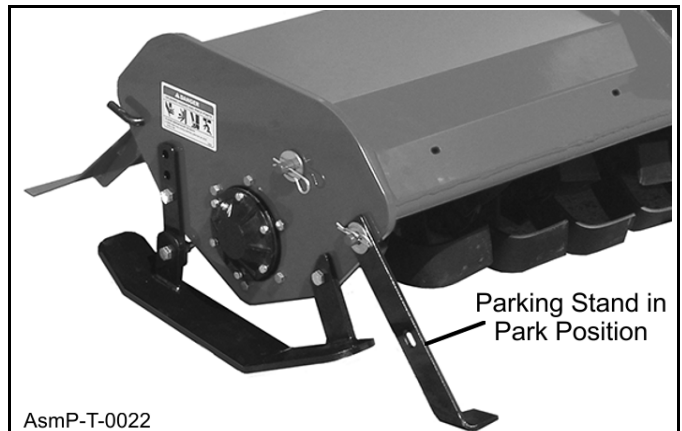

7. Place tiller on hard level surface for assembly and remove lift strap.

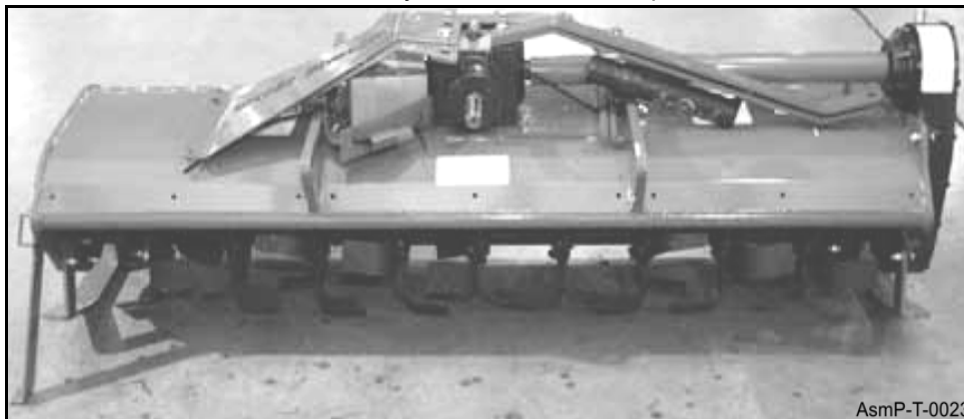

ASSEMBLY

- Carefully remove the "A" Frames, Mast Bars, "A" Frame Cover and bag of fasteners attached to the top of the machine for shipping.
- Attach the R.H. and L.H. "A" Frames to the inside of the frame braces. Use (4) 5/8" x 1-3/4" Gr. 5 capscrews, (4) 5/8" lockwashers, and (4) 5/8" hex nuts. Leave fasteners finger tight at this point of assembly.
- Assemble the "A" Frame Cover to the inside of the "A" Frame using (4) 3/8" x 1" capscrews, (4) 3/8" flatwashers (on the outside of the "A" Frame against the slotted holes), (4) 3/8" lockwashers and (4) 3/8" hex nuts.

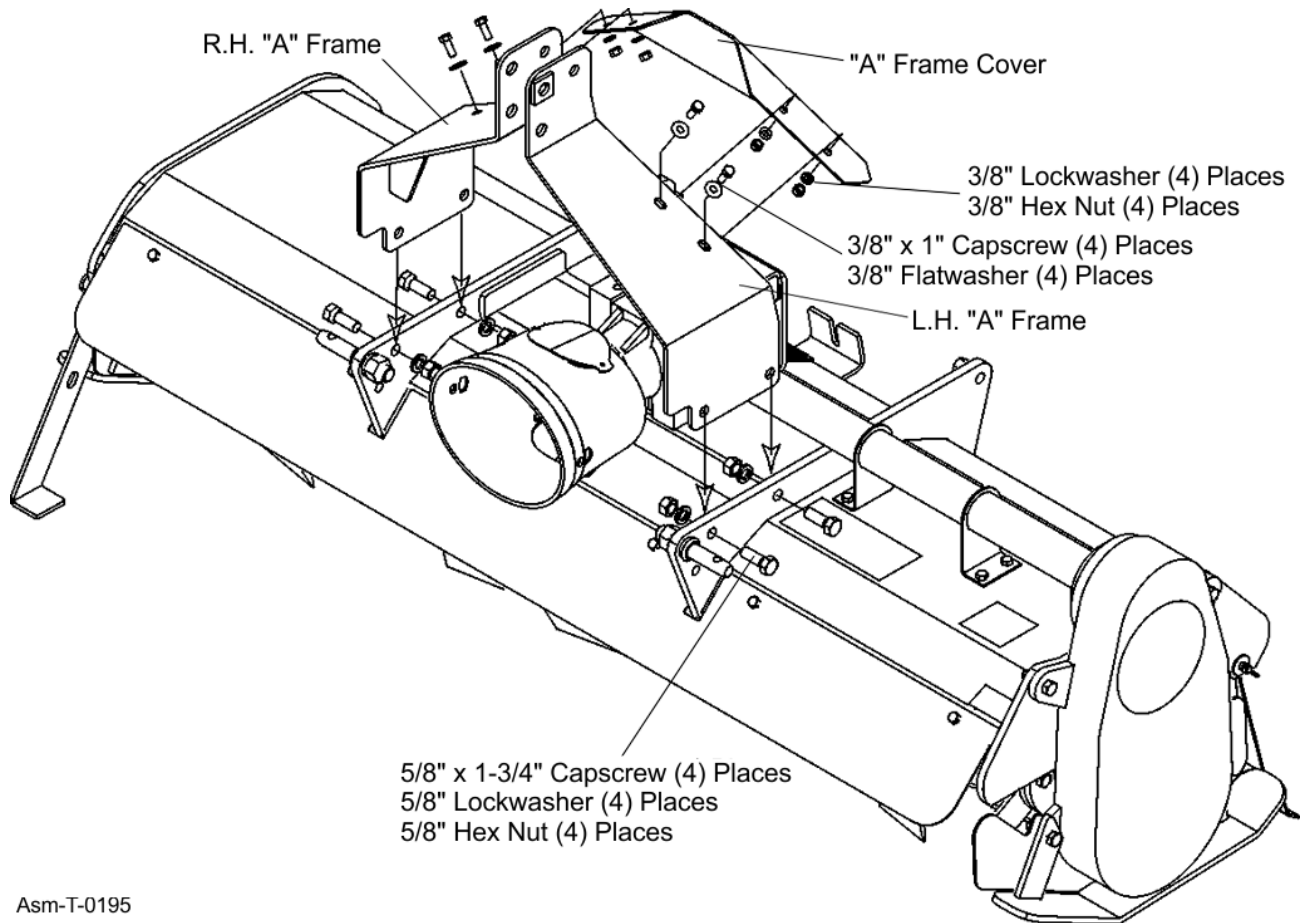

⚠ DANGER

Never work under the Implement, the framework, or any lifted component unless the Implement is securely supported or blocked up to prevent sudden or inadvertent falling which could cause serious injury or even death. (SG-14)



ASSEMBLY

ASSEMBLY

11. Attach the (2) mast bars to the inside of the frame braces using (2) 5/8" x 2" Gr. 8 capscrews, (2) 5/8" Lockwashers, (2) 5/8" Hex Nuts.
12. Place the mast bars to the outside of the top rear hole of the "A" frame. Place a bushing (2" x 1.25") between the "A" frame, align holes. Fasten with a 5/8" x 1-1/2" Gr. 5 capscrew, 5/8" lockwasher and 5/8" hex nut.
13. In the lower hole at the top front of the "A" Frame place a bushing (2" x 1.25") between the "A" Frame, align holes and install a 3/4" x 3-3/4" Gr. 5 capscrew, 3/4" lockwasher and 3/4" hex nut.
14. Tighten ALL fasteners.

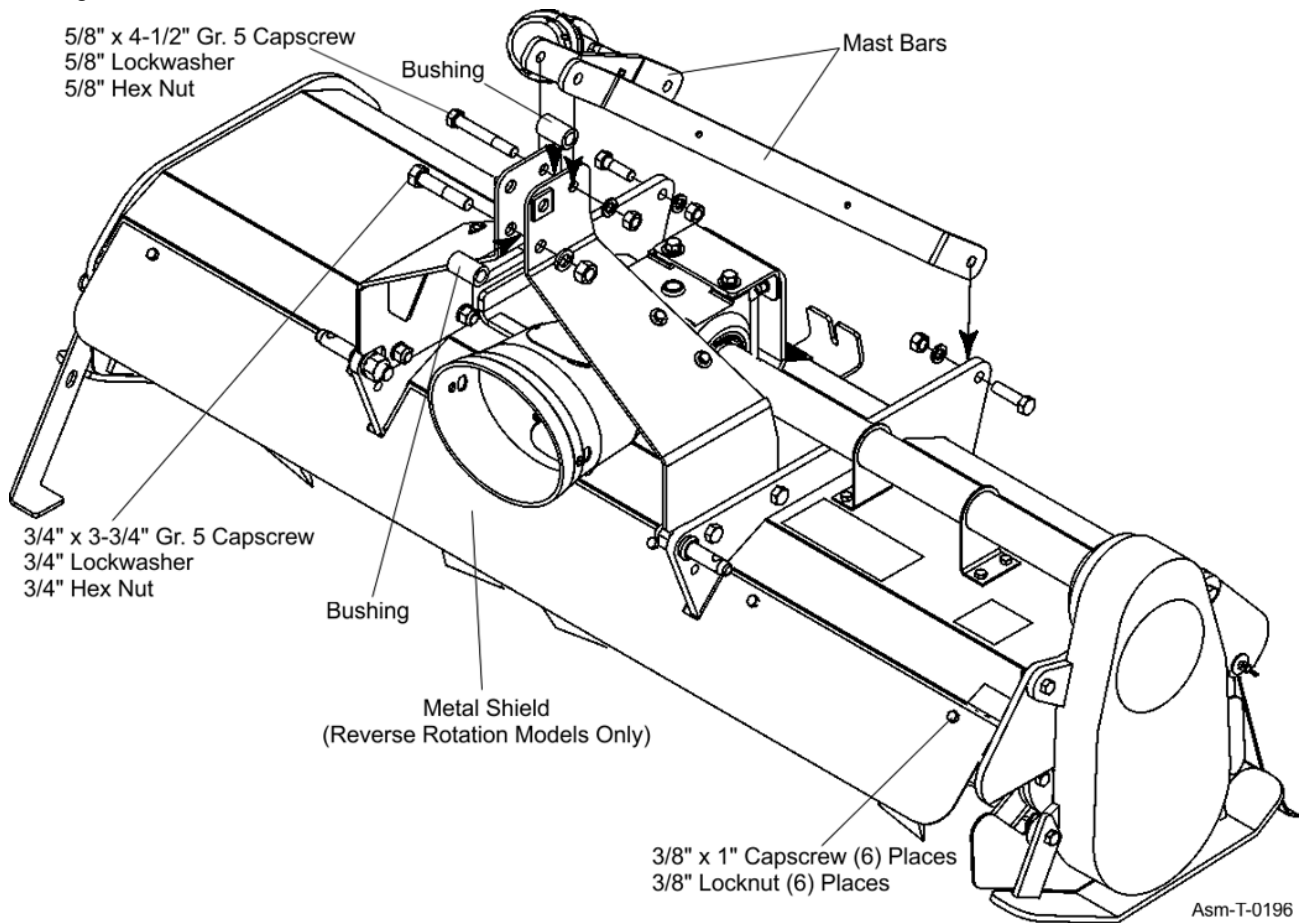

REB60R, REB72R & REB84R Reverse Rotation Models ONLY

Attach the metal shield to the front of the Tiller using (6) 3/8" x 1" capscrews and (6) 3/8" locknuts.

ASSEMBLY

DRIVELINE ATTACHMENT

Before installing driveline to tiller, make sure all dirt, paint and grease are removed from the gearbox shaft. To ease in the installation, a light coat of grease may be applied to the gearbox shaft after cleaning.

1. Remove the M12-1.25 x 65 capscrew, M12 lockwasher and M12-1.25 hex nut from the slipclutch yoke end and retain for re-installation.
2. Slide slip clutch yoke end of driveline onto the gearbox shaft.
3. Align the hole in the yoke of the slipclutch with the groove around the gearbox shaft.
4. Place the M12-1.25 x 65 capscrew through the yoke and through the groove in the shaft. Attach the M12 lockwasher and the M12 hex nut to the capscrew and tighten.

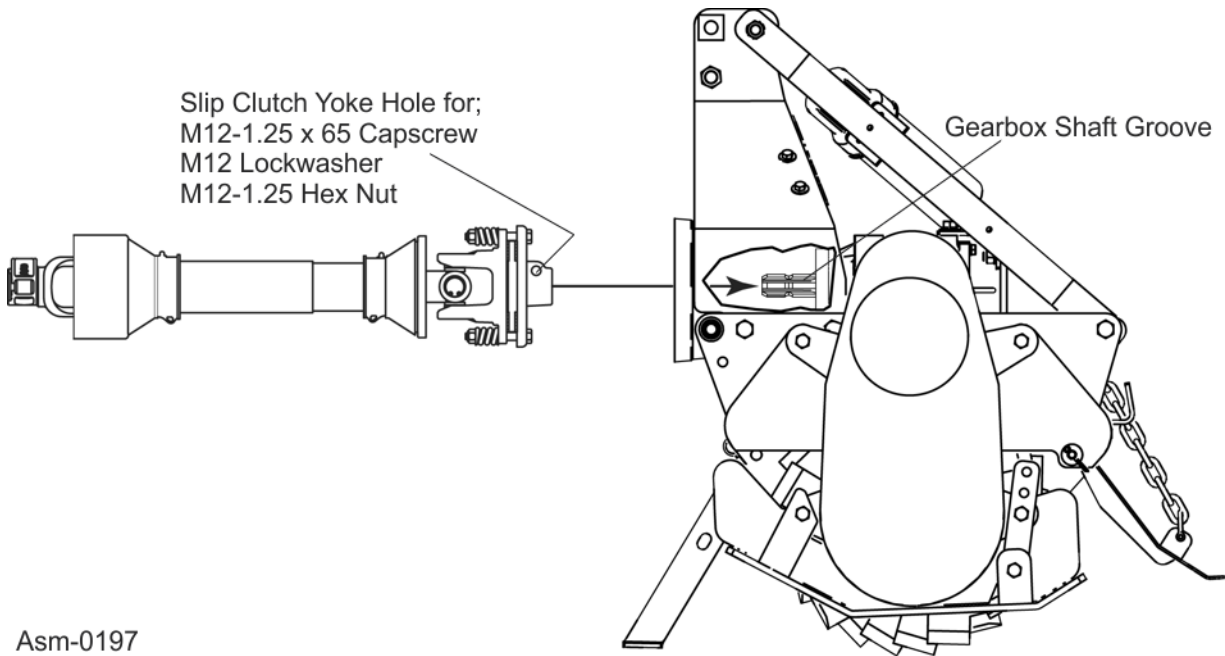

IMPORTANT: Scan this QR Code with your smart phone to link to the ADMA Driveline Safety Manual for more information on the safe use of a driveline during normal operation and maintenance. Or type in your internet browser the following web address: www.algqr.com/dme *Ops-0009-MISC*



ASSEMBLY

LUBRICATION

Important

This tiller is shipped from the factory WITHOUT oil in the gearboxes and without grease in the grease fittings. **THE UNIT MUST BE SERVICED BEFORE PUTTING INTO OPERATION.**

NOTE: Use GL5-85W 140 or Triple Zero Grease which can be poured and has an "EP" Extreme Pressure Additive. Use TYPE/GRADE II grease in all Grease Fittings.

Top Gearbox

1. Remove the vent plug on the top of the gearbox and the small inspection plug at the rear of the gearbox.
2. Pour the gear oil into the vent plug hole slowly until the oil starts to come out of the small hole at the rear. **DO NOT OVERFILL THE GEARBOX.**
3. Replace the small Inspection Plug and the Vent Plug. Clean up any excess gear oil.

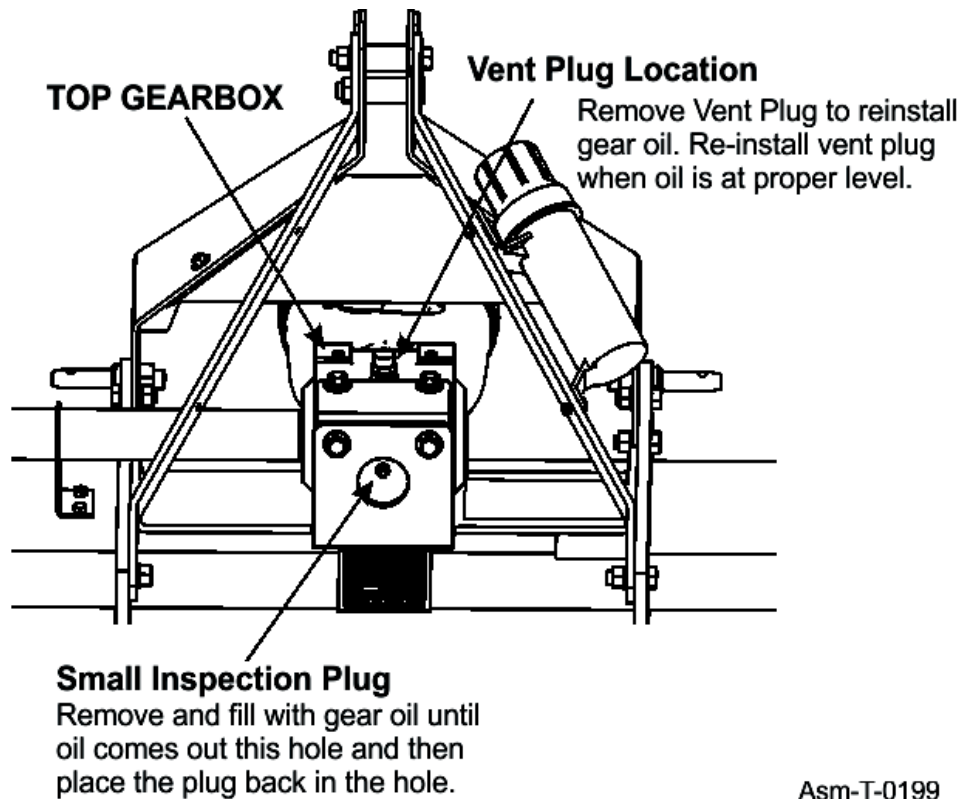

Asm-T-0199

ASSEMBLY

SIDE GEARBOX

1. Remove the vent plug on the top of the side gearbox and the small inspection plug at the side of the gearbox.
2. Pour the gear oil into the vent plug hole slowly until the oil starts to come out of the small hole on the side. **DO NOT OVERFILL THE GEARBOX.**
3. Replace the small Inspection Plug and the Vent Plug. Clean up any excess gear oil.

VENT PLUG LOCATION

Remove Vent Plug to install gear oil. Re-install vent plug when oil is at proper level.

SMALL INSPECTION PLUG

Remove and fill with gear oil until oil comes out this hole and then place the plug back into the hole.

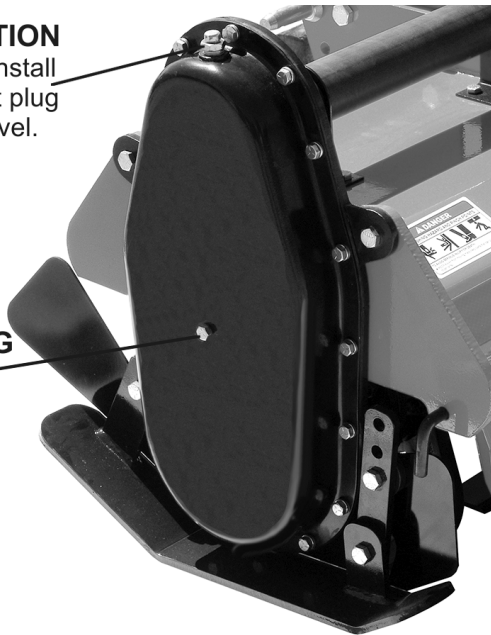

AsmP-T-0024

OUTBOARD BEARING

Grease the outboard Bearing located on the right hand side of the tiller.

GREASE FITTING
Outboard Bearing

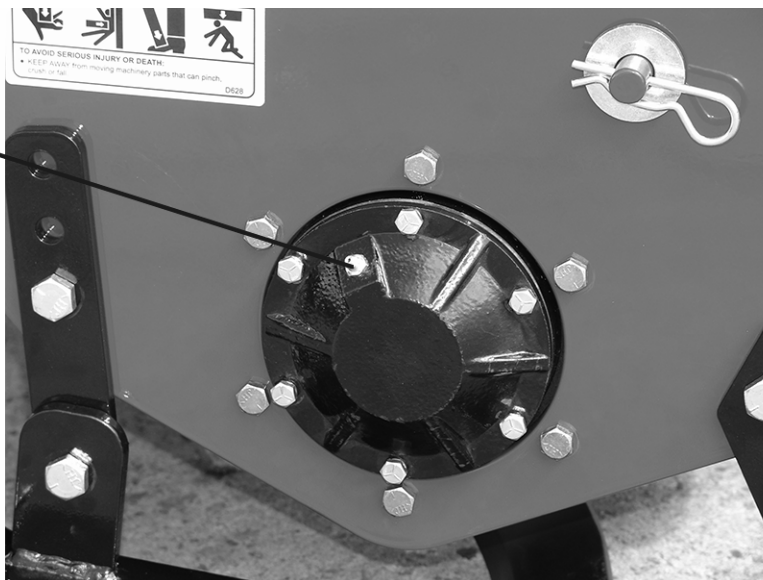

AsmP-T-0025

ASSEMBLY

CONVERTING FROM STANDARD ROTATION TO REVERSE ROTATION

To convert the REBEL Tiller, standard rotation to a reverse rotation will require the purchase of a safety shield to prevent debris from entering the operator area during operation. The required parts may be ordered from a Rhino Dealer.

Required parts are as follows:

REB60 Shield Number 50075506

REB72 Shield Number 50075093

REB84 Shield Number 50075507

Attachment will require six (6) 3/8" x 1" Grade 5 bolts and six (6) 3/8" Locknuts.



⚠ **DANGER** Serious injury or death could occur if not taking the time to secure the tiller to prevent the machine from or tipping while performing this procedure.

Safety First

Park the tiller on a hard level surface. Lower the parking stand and securely block the machine so it cannot tip or roll over during this procedure. Disconnect the tiller from the tractor and move the tractor away from the tiller.

NOTE: In the following illustrations the lift frame and struts are not pictured for clarity. It is not necessary to remove these items.

- Step 1. Remove the driveline from the gearbox assembly. Remove the input shaft shield from the front of the gearbox. Retain all fasteners for re-installation.
- Step 2. Remove the eight 1/2" x 1-3/4" bolts, hex nuts and lockwashers attaching the tine bar to the side gearbox and the right side hub. Carefully roll the tine bar from under the tiller mainframe out of the way.
- Step 3. Remove the 1/2" x 1-1/4" bolts, lockwashers and flatwashers attaching the gearbox to the gearbox plate. Loosen the 1/2" x 1-1/2" bolts, lockwashers and flatwashers attaching the gearbox plate to the rear bracket.
- Step 4. Remove the four 1/2" x 1-3/4" bolts and lockwashers located on the underside of the frame attaching the gearbox.

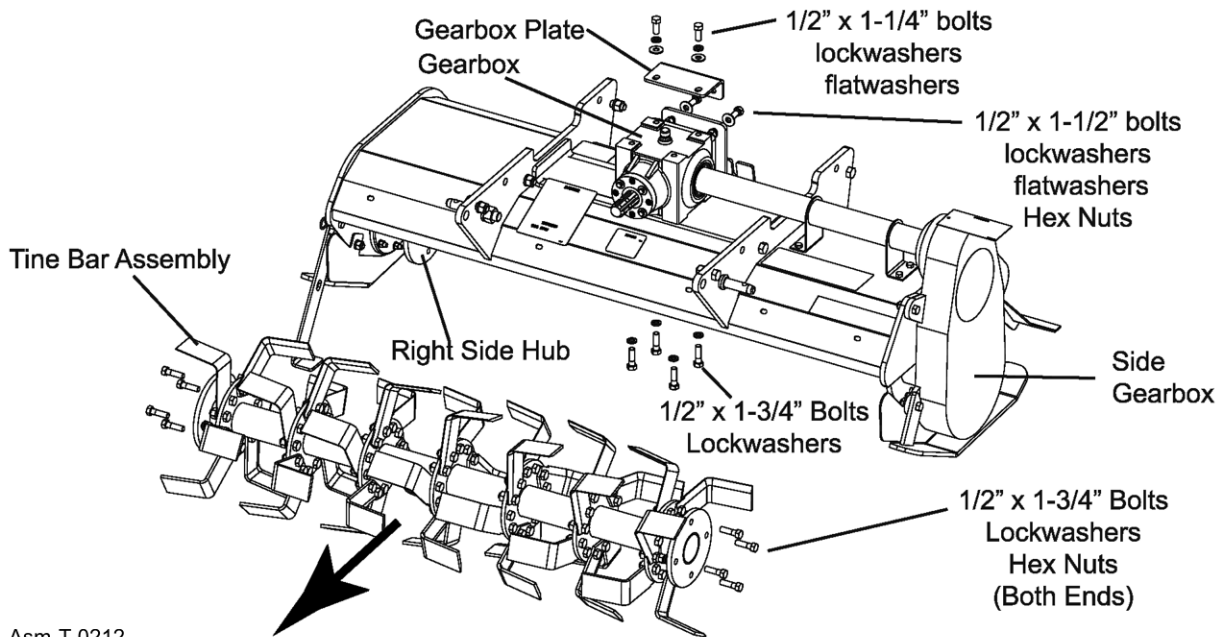

Asm-T-0212

ASSEMBLY

Step 5. Slide the gearbox to the right until it clears the driveshaft. Remove the gearbox and place it on a clean level surface with the back of the gearbox down and the input shaft pointing up. This is to prevent the oil from running out while swapping the location of the breather plug and the oil plug on the bottom of the box.

Asm-T-0213

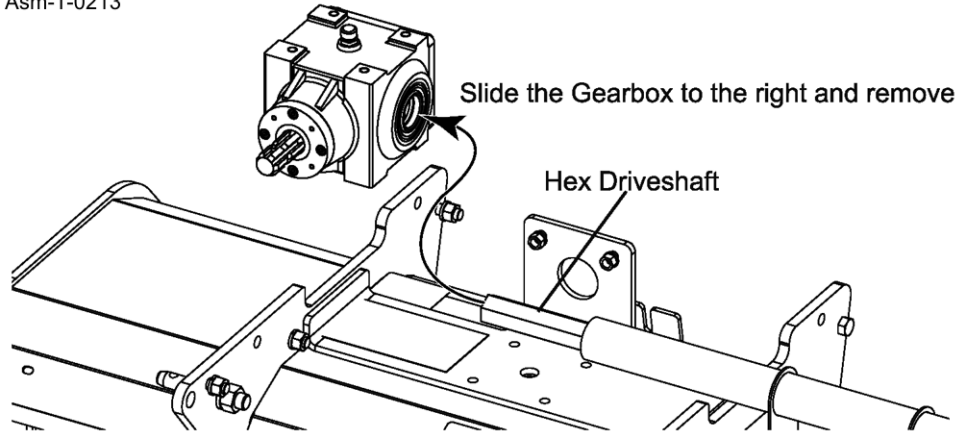

Step 6. Swap locations of the vent plug and the oil plug so the vent plug is where the oil plug was and the oil plug is where the vent plug was.

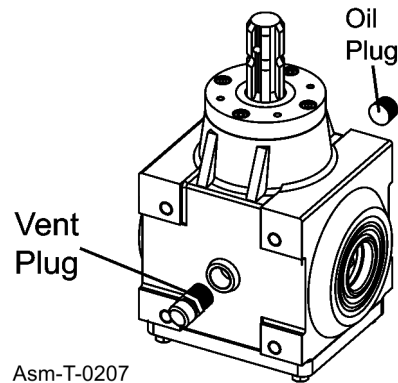

Step 7. Remove the snap ring and flatwasher from the inside of the hex tube and reinstall to the opposite side. Place the flatwasher in first, then secure in place with the snap ring, then secure in place with the snap ring.

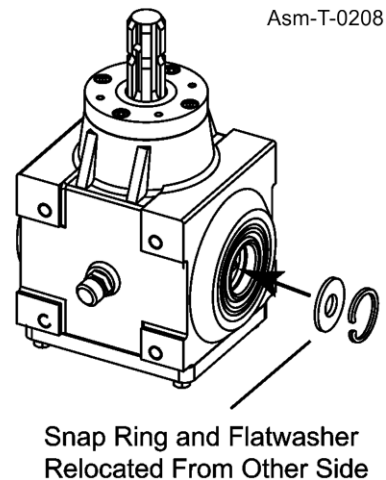

ASSEMBLY

ASSEMBLY

Step 8. Place the gearbox on the mainframe with the vent plug on top. Move the gearbox in place, aligning the hex shaft and the tube through the gearbox. Align the four holes in the mainframe with the gearbox mounting holes and reinstall the four 1/2" x 1-3/4" bolts and lockwashers previously removed from this location. Reattach the gearbox mounting plate to the gearbox with the two 1/2" x 1-1/4" bolts, lockwashers and flatwashers previously removed.

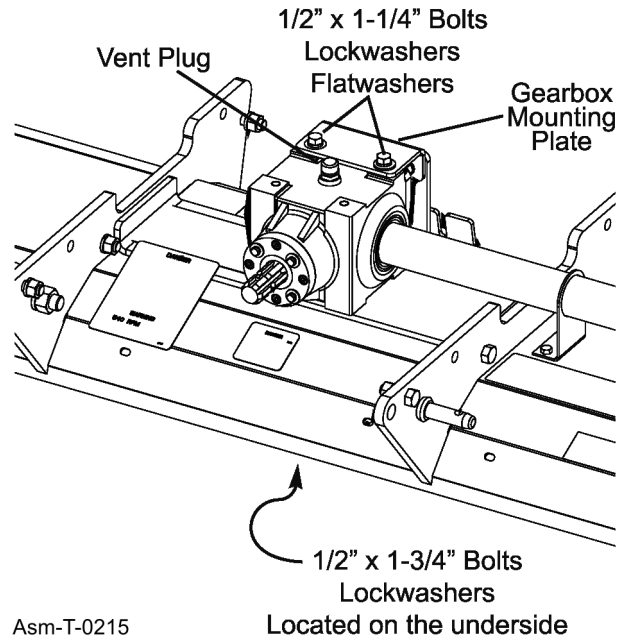

Step 9. Turn the tine bar 180 degrees from the original position when removed. Reattach the tine bar assembly to the tiller using the eight 1/2" x 1-3/4" bolts, lockwashers and hex nuts.

NOTE: If the fasteners are damaged or worn from previous usage, replace them.

With the tine bar assembly in place, at ground level, the cutting edge of the tines should be toward the front (facing forward).

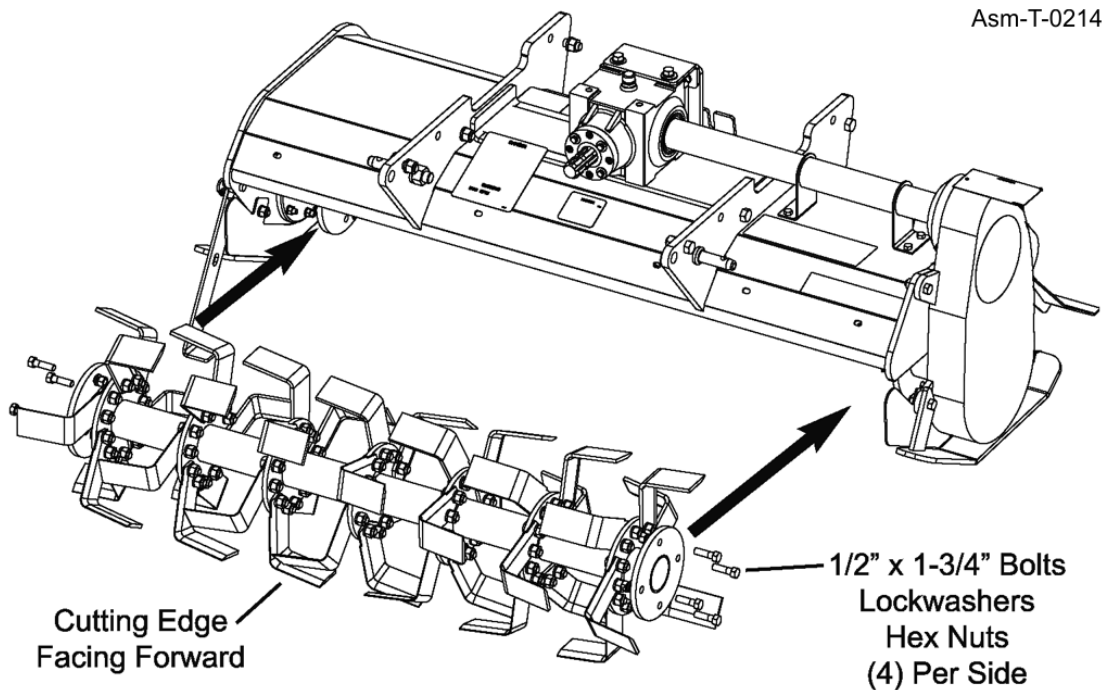

ASSEMBLY

Step 10. Place the shield to the front lip of the tiller and align the holes with the slotted holes in the mainframe. Use six 3/8" x 1" Grade 5 bolts and 3/8" locknuts to attach the shield.

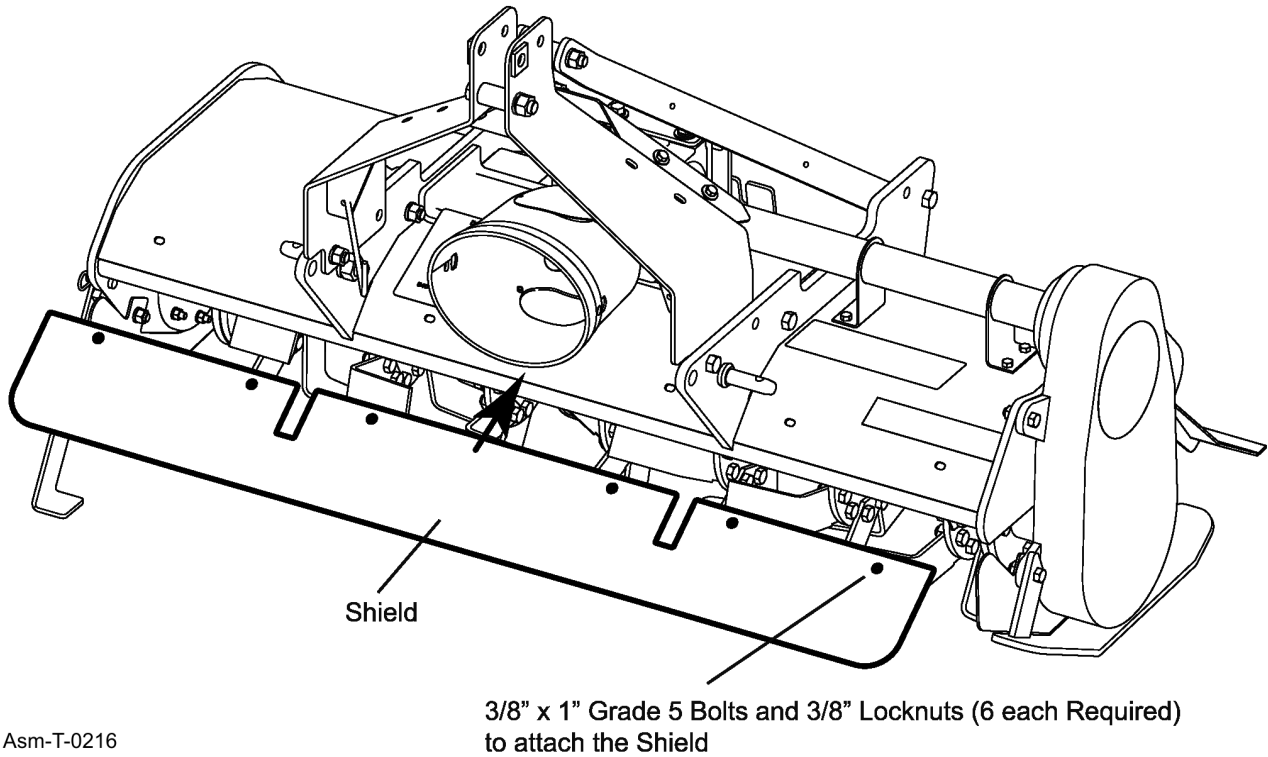

Asm-T-0216

Step 11. Reattach the gearbox input shaft shield and driveshaft to the input shaft.

NOTE: Before operating make sure all fasteners that have been removed and reinstalled are tightened.

ASSEMBLY

OPERATION SECTION

OPERATION

RHINO REBEL SERIES TILLER OPERATION INSTRUCTIONS

The Tiller is manufactured with quality material by skilled workers. This implement is ideal in horticultural, agricultural, or commercial applications, especially for landscapers, rental yards, vineyards, vegetable farms, and nurseries. The implement is equipped with protective deflectors to prevent objects being thrown from the implement by the blades, however, no shielding is 100% effective. All shields, guards, and deflectors equipped on the unit must be maintained on the implement in good operational condition.

It is the operator's responsibility to be knowledgeable of all potential operating hazards and to take every reasonable precaution to ensure oneself, others, animals, and property are not injured or damaged by the implement, tractor, or a thrown object. Do not operate the implement if passersby, pets, livestock, or property are directly in front or to the rear of the unit.

This section of the Operator's Manual is designed to familiarize, instruct, and educate safe and proper implement use to the operator. Pictures contained in this section are intended to be used as a visual aid to assist in explaining the operation of a implement tiller. Some pictures may show shields removed for purposes of clarity. **NEVER OPERATE** this implement without all shields in place and in good operational condition. The operator must be familiar with the implement and tractor operation and all associated safety practices before operating the implement and tractor. Proper operation of implement, as detailed in this manual, will help ensure years of safe and satisfactory use of the implement.

IMPORTANT: To avoid implement damage, retorque all bolts after the first 10 hours of operation. Refer to the Torque Chart at the end of the Maintenance Section to ensure bolts are properly tightened.

READ AND UNDERSTAND THE ENTIRE OPERATING INSTRUCTIONS AND SAFETY SECTION OF THIS MANUAL AND THE TRACTOR MANUAL BEFORE ATTEMPTING TO USE THE TRACTOR AND IMPLEMENT. If you do not understand any of the instructions, contact your nearest authorized dealer for a full explanation. Pay close attention to all safety signs and safety messages contained in this manual and those affixed to the implement and tractor. *OPS-U-0001*

READ, UNDERSTAND, and FOLLOW the following Safety Messages. Serious injury or death may occur unless care is taken to follow the warnings and instructions stated in the Safety Messages. Always use good common sense to avoid hazards. (SG-2)



OPERATION

1. Standard Equipment and Specifications

REB Series

	<u>REB60 & REB60R</u>	<u>REB72 & REB72R</u>	<u>REB84 & REB 84R</u>
Tilling Width	59"	70-1/2"	82-1/2"
Overall Width	66"	78"	90"
Type of Knives	"L"	"L"	"L"
Knives Per Flange	6	6	6
Number of Flanges	7	9	11
Tilling Depth	*7-1/2"	*7-1/2"	*7-1/2"
Skid Shoe Settings	3	3	3
Rated Rotor Speed (RPM)	211 RPM	211 RPM	211 RPM
Gearbox Housing	Cast	Cast	Cast
Deck Thickness	.1345"	.1345"	.1345"
End Plate Thickness	0.50"	0.50"	.50"
Required Tractor HP	25-45 HP	35-55 HP	45-65 HP
Driveline Size	Cat 4	Cat 4	Cat 4
Gearbox Protection	Slip Clutch	Slip Clutch	Slip Clutch
Rotor Drive Type	Gear Driven	Gear Driven	Gear Driven
Hitch	Cat I & Cat I QH	Cat I & Cat I QH	Cat 1 & Cat 1 QH Cat 2 & Cat 2 QH

*Requires Multiple Passes



Operating this implement in an application for which it is not designed and/or operating the implement with the wrong size Tractor can cause implement component damage and equipment failure resulting in possible serious injury or death.

OPERATION

2. OPERATOR REQUIREMENTS

Safe operation of the unit is the responsibility of a qualified operator. A qualified operator has read and understands the implement and tractor Operator's Manuals and is experienced in implement and tractor operation and all associated safety practices. In addition to the safety messages contained in this manual, safety signs are affixed to the implement and tractor. If any part of the operation and safe use of this equipment is not completely understood, consult an authorized dealer for a complete explanation.

If the operator cannot read the manuals for themselves or does not completely understand the operation of the equipment, it is the responsibility of the supervisor to read and explain the manuals, safety practices, and operating instructions to the operator.

Safe operation of equipment requires that the operator wear approved Personal Protective Equipment (PPE) for the job conditions when attaching, operating, servicing, and repairing the equipment. PPE is designed to provide operator protection and includes the following safety wear:

PERSONAL PROTECTIVE EQUIPMENT (PPE)

- Always Wear Safety Glasses
- Hard Hat
- Steel Toe Safety Footwear
- Gloves
- Hearing Protection
- Close Fitting Clothing
- Respirator or Filter Mask (depends on operating conditions) OPS-U- 0002

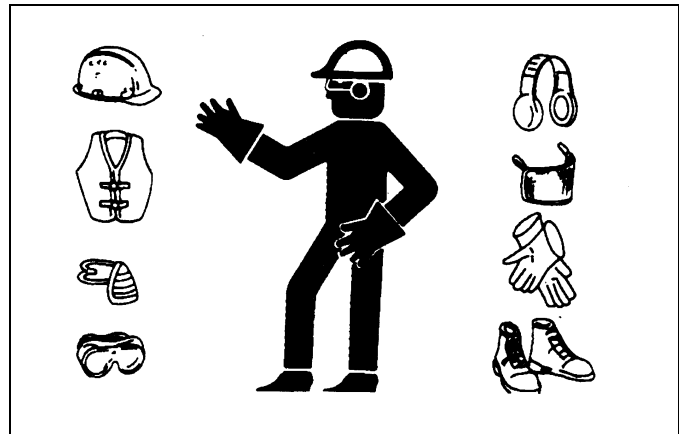

▲ DANGER

DO NOT use drugs or alcohol immediately before or while operating the Tractor and Implement. Drugs and alcohol will affect an operator's alertness and coordination and therefore affect the operator's ability to operate the equipment safely. Before operating the Tractor or Implement, an operator on prescription or over-the-counter medication must consult a medical professional regarding any side effects of the medication that would hinder their ability to operate the Equipment safely. NEVER knowingly allow anyone to operate this equipment when their alertness or coordination is impaired. Serious injury or death to the operator or others could result if the operator is under the influence of drugs or alcohol. (SG-27)

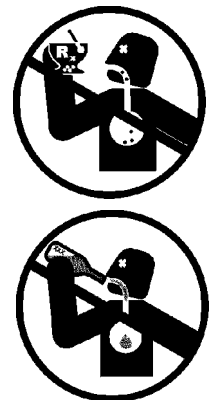

TRACTOR REQUIREMENTS

OPERATION

The tractor used to operate the implement must have the power capacity to lift, pull, and operate the Power Take Off (PTO) at the implement's rated speed while traveling at a ground speed between 2 and 5 MPH. Operating the implement with a tractor that does not meet the following requirements may cause tractor or implement damage and be a potential danger to the operator and passersby.

Tractor Requirements and Capabilities

- ASABE approved Roll-Over Protective Structure (ROPS) or ROPS cab and seat belt.
- Slow Moving Vehicle (SMV) emblem, lighting, PTO master shield
- Tractor Horsepower:
 - REB60/REB60R 25 - 45 HP
 - REB72/REB72R 35 - 55 HP
 - REB84/REB84R 45 - 65 HP
- Hitch- Lifting Capacity
 - REB60, REB60R Minimum 700 lbs.
 - REB72, REB72R Minimum 780 lbs.
 - REB84, REB84R Minimum 850 lbs.
- 3-Point Hitch..... CAT I / CAT I QH (REB60, REB60R, REB72, REB72R)
CAT1/Cat1 QH & Cat 2 / Cat 2 QH (REB84 & REB84R)
- Front End Weight As needed to maintain 20% weight on front axle
- Power Take Off..... 540 RPM 6-spline, 1-3/8" diameter output shaft

2.1 ROPS and Seat Belt

The tractor must be equipped with a Roll-Over-Protective-Structure (ROPS) (tractor cab or roll-bar) and seat belt to protect the operator from falling off the tractor, especially during a roll over where the driver could be crushed and killed. Only operate the tractor with the ROPS in the raised position and seat belt fastened. Tractor models not equipped with a ROPS and seat belt should have these life saving features installed by an authorized dealer. *OPS-U- 0003*



Operate this Equipment only with a Tractor equipped with an approved roll-over-protective system (ROPS). Always wear seat belts. Serious injury or even death could result from falling off the tractor--particularly during a turnover when the operator could be pinned under the ROPS. (SG-7)



2.2 Tractor Safety Devices

If transporting or operating the tractor and implement near a public roadway, the tractor must be equipped with proper warning lighting and a Slow Moving Vehicle (SMV) emblem which are clearly visible from the rear of the unit. Lights and a SMV emblem must be equipped directly on implements if the visibility of the tractor warning signals are obscured.

Maintain all manufacturer equipped safety shields and guards. Always replace shields and guards that were removed for access to connect, service, or repair the tractor or implement. Never operate the tractor PTO with the PTO master shield missing or in the raised position. *OPS-U- 0004*

OPERATION

2.3 Tractor Horsepower

The power required to operate an implement is determined by the tractor PTO horsepower. For most operating conditions, implement requires a tractor with at least 10 HP. Operating the implement with a tractor that does not have adequate power may damage the tractor engine. Exceeding required HP may cause implement damage by overpowering the unit in heavy cutting conditions.

2.4 3-Point Hitch

These tillers are designed to be mounted on a tractor with a CAT I 3-point hitch. Refer to the tractor operator's manual for the category of the tractor being used. If the hitch does not conform to ASABE CAT I dimensions, the tiller may not fit or raise properly. Consult an authorized dealer for possible modification procedures to mount non-conforming hitches.

Depending on the hitch category, certain size pins are used to attach the implement to the tractor. CAT I hitches require 7/8" lower hitch pins and a 3/4" pin at the top link connection.

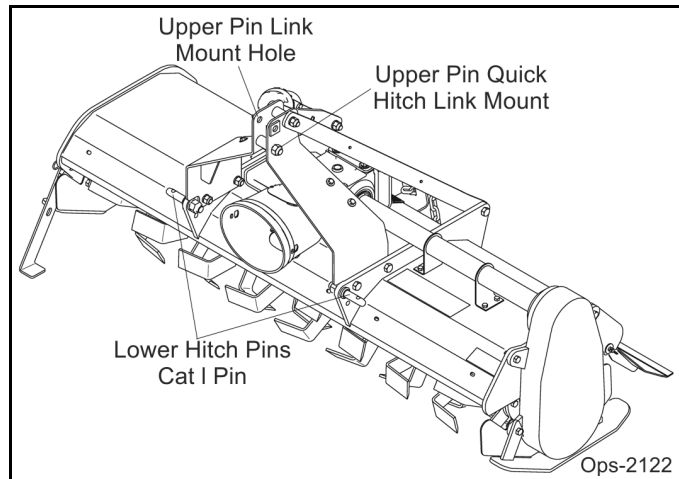

CAT I Implement / Hitch Specification

Width from outside to outside A-frame	26-7/8"
Quick hitch width inside lug to lug	27-1/8"
Height from bottom hitch pin to top pin	18"
Lower pin diameter.....	7/8"
Upper pin diameter.....	3/4"
Linch pin diameter.....	15/32"

CAT II Implement / Hitch Specification

Width from outside to outside A-frame	32-3/8"
Quick hitch width inside lug to lug	33-5/8"
Height from bottom hitch pin to top pin.....	19"
Lower pin diameter.....	7/8"
Upper pin diameter.....	1"
Linch pin diameter.....	15 32"

2.5 Front End Weight

A minimum of 20% total tractor weight must be maintained on the tractor front end at all times. Front end weight is critical to maintain steering control and to prevent the tractor from rearing up while driving. If the front end is too light, add weight until a minimum of 20% total weight is reached on the front tires. Front weights and weight carriers can be purchased through an authorized tractor dealership. OPS-U- 0005

2.6 Power Take Off (PTO)

The tiller is designed to operate at a PTO speed of 540 RPM. Most tractors operate at either 540, or a combination of 540 and 1000 RPM PTO speeds. The operating speed of the tiller and tractor can be determined by the number of splines on the driveline yoke and PTO output shaft. Those operating at 540 RPM will have a 6-spline, 1-3/8" diameter shaft and those operating at 1000 RPM will have a 21-spline, 1-3/8" diameter shaft. **Note:** The tiller will not and must not operate on tractors equipped with a 1000 RPM 20-spline, 1-3/4" shaft.

OPERATION



DO NOT use a PTO adapter to attach a non-matching Implement driveline to a Tractor PTO. Use of an adapter can double the operating speed of the Implement resulting in excessive vibration, thrown objects, and blade and implement failure. Adapter use will also change the working length of the driveline exposing unshielded driveline areas. Serious bodily injury and/or equipment failure can result from using a PTO adapter. Consult an authorized dealer for assistance if the Implement driveline does not match the Tractor PTO. (S3PT-14)

3. GETTING ON AND OFF THE TRACTOR

Before getting onto the tractor, the operator must read and completely understand the implement and tractor operator manuals. If any part of either manual is not completely understood, consult an authorized dealer for a complete explanation. *OPS-U- 0007*



Do not mount or dismount the Tractor while the tractor is moving. Mount the Tractor only when the Tractor and all moving parts are completely stopped. (SG-12)



3.1 Boarding the Tractor

Use both hands and equipped handrails and steps for support when boarding the tractor. Never use control levers for support when mounting the tractor. Seat yourself in the operator's seat and secure the seat belt around you.

Never allow passengers to ride on the tractor or attached equipment. Riders can easily fall off and be seriously injured or killed from falling off and being ran over. It is the operator's responsibility to forbid all extra riders at all times. *OPS-U- 0008*



Never allow children to operate, ride on, or come close to the Tractor or Implement. Usually, 16-17 year-old children who are mature and responsible can operate the implement with adult supervision, if they have read and understand the Operator's Manuals, been trained in proper operation of the tractor and Implement, and are physically large enough to reach and operate the controls easily. (SG-11)



Never allow children or other persons to ride on the Tractor or Implement. Falling off can result in serious injury or death. (SG-10)



OPERATION

3.2 Dismounting the Tractor

Before dismounting, park the tractor and implement on a reasonably level surface, apply the parking brake, idle the engine down, disengage the PTO, and lower the implement to the ground. Shut down the tractor engine according to the operator's manual, remove the key, and wait for all motion to completely stop. Never leave the seat until the tractor, its engine and all moving parts have come to a complete stop.

Use hand rails and steps when exiting the tractor. Be careful of your step and use extra caution when mud, ice, snow or other matter has accumulated on the steps or hand rails. Use all handrails and steps for support and never rush or jump off the tractor. OPS-U- 0009



BEFORE leaving the tractor seat lower the implement, set the parking brake and/or set the tractor transmission in parking gear, disengage the PTO, stop the engine, remove the key, and wait for all moving parts to stop. Place the tractor shift lever into a low range or parking gear to prevent the tractor from rolling. Never dismount a Tractor that is moving or while the engine is running. Operate the Tractor controls from the tractor seat only. (SG-9)

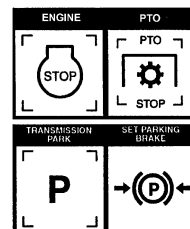

4. STARTING THE TRACTOR

The operator must have a complete understanding of the placement, function, and operational use of all tractor controls before starting the tractor. Review the tractor operator's manual and consult an authorized dealer for tractor operation instructions if needed.

Essential Tractor Controls:

- Locate the light control switch.
- Locate the engine shut off control.
- Locate the brake pedals and the clutch.
- Locate the PTO control.
- Locate the 3-point hitch control lever.
- Locate the hydraulic remote control levers.

Before starting the tractor ensure the following:

- Conduct all pre-start operation inspection and service according to the tractor operator's manual.
- Make sure all guards, shields, and other safety devices are securely in place.
- The parking brake is on.
- The PTO control lever is disengaged.
- The 3-point hitch control lever is in the lowered position.
- The hydraulic remote control levers are in the neutral position.
- The tractor transmission levers are in park or neutral.

Refer to the tractor owner's manual for tractor starting procedures. Only start the tractor while seated and belted in the tractor operator's seat. Never bypass the ignition switch by short circuiting the starter solenoid.

After the tractor engine is running, avoid accidental contact with the tractor transmission to prevent sudden



Never run the Tractor engine in a closed building or without adequate ventilation. The exhaust fumes can be hazardous to your health. (SG-23)

OPERATION



Start tractor only when properly seated in the Tractor seat. Starting a tractor in gear can result in injury or death. Read the Tractor operators manual for proper starting instructions. (SG-13)



5. CONNECTING THE IMPLEMENT TO THE TRACTOR

Use extreme caution when connecting the Implement to the tractor. The implement should be securely resting at ground level or setting on blocks. Keep hands and feet from under the implement deck and clear of pinch points between the tractor hitch arms and implement pins. OPS-T-0001



Always shut the Tractor completely down, place the transmission in park, and set the parking brake before you or anyone else attempts to connect or disconnect the Implement and Tractor hitches. (S3PT-15)

5.1 Connecting the Implement

1. Make sure the tractor is equipped with the correct PTO shaft. Change shafts if needed.
2. Shorten or remove the tractor drawbar to avoid interference when raising and lowering the implement.
3. Board the tractor and start the engine. Position the tractor to the implement with the 3-point lift arms positioned at the same height and to the outside of the implement hitch pins. **Note:** Set the 3-point lift control to "Position Control" so that the lift arms maintain a constant height when attaching the implement. See the tractor Operator's Manual for correct settings when attaching 3-point equipment.
4. Turn off the tractor engine and dismount.
5. One lift arm at a time, align arm end hole between the set of A-frame lift lugs. Insert hitch pin through the lug and arm holes and insert retaining pin into hitch pin.
6. Walk around to opposite side and repeat procedure for remaining lift arm and hitch pin.
7. Extend or retract 3-point top link to align its end hole with the holes of the implements top link. Insert the top link hitch pin and insert retaining pin into hitch pin.
8. Adjust any lower link check chains, guide blocks, or sway blocks to prevent the implement from swaying side to side and possible contact with tractor rear tires.

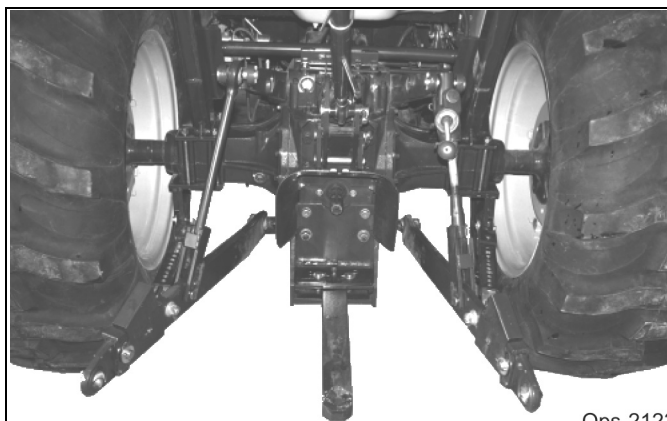

Ops-2123



Op - 128

OPERATION

IMPORTANT: Scan this QR Code with your smart phone to link to the PAMI Safe Implement Hitching Manual for more information on correctly connecting agricultural tractors to implements. Or type in your internet browser the following web address: www.algqr.com/hme *Ops-0008-MISC*

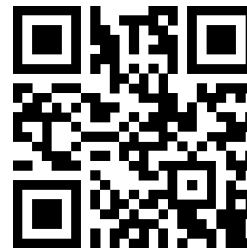

OPERATION

5.2 Setting Implement Height

1. Park the tractor and implement on level ground.
2. Using the 3-point hitch control lever, position the front of the implement with its side skids 1" less off the ground than desired operational height. For example, for a 3" operational height, position the skids 2" from the ground. Set the 3-point control lever stop at this position to maintain this height when raising and lowering the implement.
3. Shut down the tractor and remove the key.
4. Level the implement deck front to rear by extending or retracting the 3-point top link.
5. Level the implement side to side by manipulating one lower lift arm length. On most tractors, at least one of the lift arms is designed to allow for manipulation of its length. Shortening or extending will allow for deck leveling from side to side.
6. Securely block up the implement at this height.

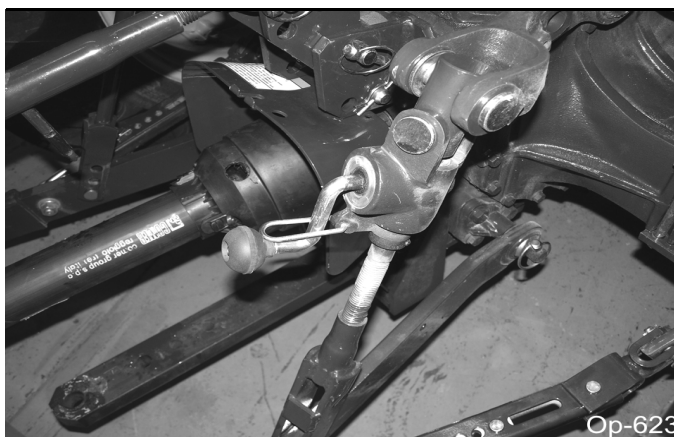

OPERATION

6. DRIVELINE ATTACHMENT

The driveline yoke and tractor PTO shaft must be dirt free and greased for attachment.

To connect the mower driveline to the tractor PTO output shaft, pull the driveline yoke collar back and align the grooves and splines of the yoke with those of the PTO shaft. Push the driveline yoke onto the PTO shaft, release the locking collar, and position the yoke until the locking collar balls are seated onto the PTO shaft. Push and pull the driveline back and forth several times to ensure a secure attachment. *OPS-R-0003_D*



⚠️ WARNING

When attaching the Implement input driveline to the Tractor PTO, it is important that the connecting yoke spring activated locking collar slides freely and the locking balls are seated securely in the groove on the Tractor PTO shaft. Push and pull the driveline back and forth several times to ensure it is securely attached. A driveline not attached correctly to the Tractor PTO shaft could come loose and result in personal injury and damage to the Implement. (S3PT-17)

6.1 Driveline Length Check

⚠️ WARNING

Before operating the Implement, check to make sure the Implement input driveline will not bottom out or become disengaged. Bottoming out occurs when the inner shaft penetrates the outer housing until the assembly becomes solid-it can shorten no more. Bottoming out can cause serious damage to the Tractor PTO by pushing the PTO into the Tractor and through the support bearings or downward onto the PTO shaft, breaking it off. A broken driveline can cause personal injury. (S3PT-18)

When fitting the implement to the tractor, the telescoping driveline must be inspected to ensure that at its most compressed position, the profiles do not “bottom out”, and when at its farthest extended position, there is sufficient engagement between the profiles to operate safely. At its shortest length, there must be at least a 1” clearance between each profile end and opposite profile universal joint. At its farthest operating extension, a minimum profile engagement of 9” must be maintained.

OPERATION

“Bottoming Out” Check Procedure

- Disconnect driveline from the tractor and slide the profiles together until fully compressed.
- Place a mark on the inner shield 1/8” from the end of the outer shield.
- Reattach the driveline to the PTO Shaft.
- With the PTO NOT TURNING, raise and lower the tiller and watch shaft movement.
- Raise the tiller and watch the driveline as it approaches the mark. If the distance between the mark and the end of the outer shield tube becomes less than 2” at any point, contact your local dealer or tech service for proper directions. OPS-T-0014

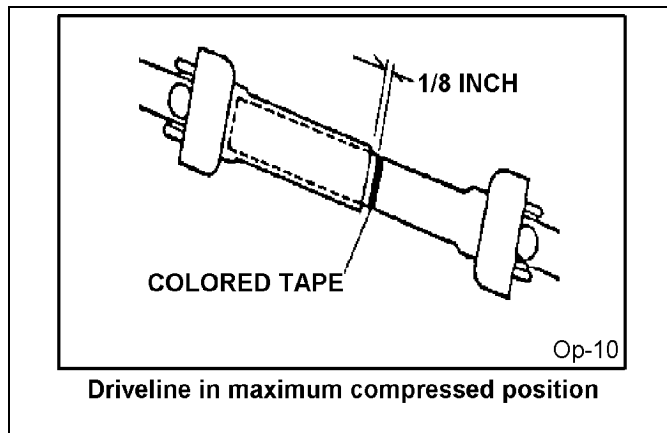

Shorten the driveline profiles as follows:

- Remove the driveline from the tractor.
- Position the tiller (Lift Type - Raise and lower) to the point with the shortest distance between the tractor PTO shaft and implement gearbox. Shut down the tractor and securely block the tiller in this position.
- Pull driveline apart and reattach yoke to PTO shaft.
- Hold driveline sections parallel to one another and measure back 1” from yoke of each shaft and place mark on opposite section. Cut this length off with a saw.
- Round off all sharp edges and debur.
- Thoroughly grease then reinstall the driveline.
- Recheck for proper operation.

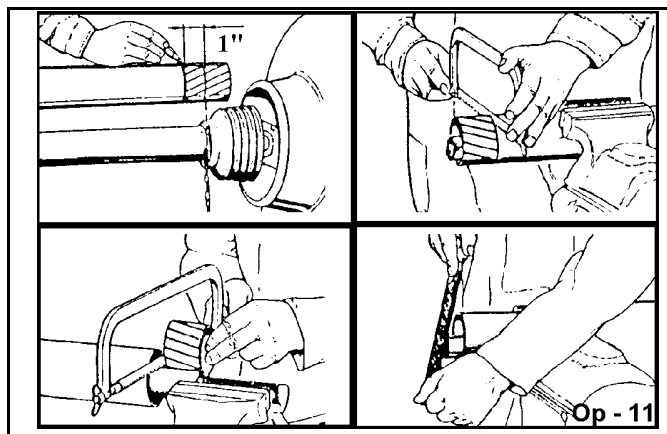

Engagement Check Procedure

- *With the driveline attached, position the tiller to the point where the telescoping driveline is at its maximum extension. Completely shut down the tractor and secure in position.*
- Mark the inner driveline shield 1/8” from the end of the outer shield.
- Disconnect the driveline from the tractor and separate the two driveline halves.
- Measure the distance from the mark to the end of the inner profile. This length is the amount the driveline profiles were engaged.
- If the engaged length is less than 6” for a non-CV driveline, the shaft is considered too short and should be replaced with a longer shaft. Consult an authorized dealer to purchase the required driveline length.

NOTE: *When raising the tiller, at least 1” clearance must be maintained between the driveline and the tiller. If necessary, place an upper lift stop on the 3-point hitch control lever to limit the height the tiller can be raised.*

OPS-T-0015

OPERATION

7. PRE-OPERATION INSPECTION AND SERVICE

Before each use, a pre-operation inspection and service of the implement and tractor must be performed. This includes routine maintenance and scheduled lubrication, inspecting that all safety devices are equipped and functional, and performing needed repairs. DO NOT operate the unit if the pre-operation inspection reveals any condition affecting safe operation. Perform repairs and replacement of damaged and missing parts as soon as noticed. By performing a thorough pre-operation inspection and service, valuable down time and repair cost can be avoided. *OPS-U-0029*

DANGER

Always disconnect the main PTO Driveline from the Tractor before performing service on the Implement. Never work on the Implement with the tractor PTO driveline connected and running. Rotating Parts, Blades or Drivelines could turn without warning and cause immediate entanglement, injury or death. (S3PT-11)

WARNING

Periodically inspect all moving parts for wear and replace when necessary with authorized service parts. Look for loose fasteners, worn or broken parts, and leaky or loose fittings. Make sure all pins have cotter pins and washers. Serious injury may occur from not maintaining this machine in good working order. (SG-21)

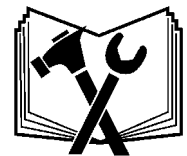

OPERATION

7.1 Tractor Pre-Operation Inspection/Service

Refer to the tractor operator's manual to ensure a complete pre-operation inspection and scheduled service is performed according to the manufacturers recommendations. The following are some of the items that require daily service and inspection:

- Tire condition/air pressure
- Wheel lug bolts
- Steering linkage
- PTO shield
- SMV sign is clean and visible
- Tractor's lights are clean and functional
- Tractor Seat belt is in good condition
- Tractor ROPS is in good condition
- ROPS is in the raised position
- No tractor oil leaks
- Radiator free of debris
- Engine oil level and condition
- Engine coolant level and condition
- Power brake fluid level
- Power steering fluid level
- Fuel condition and level
- Sufficient lubrication at all lube points
- Air filter condition *OPS-U-0030*



7.2 Implement Pre-Operation Inspection/Service

Before each implement use, a complete inspection and service is required to ensure the implement is in a good and safe working condition. Damaged and/or broken parts should be repaired and/or replaced immediately. To ensure the implement is ready for operation, conduct the following. *OPS-T-0002*

The operator's manual and safety signs affixed on the unit contain important instructions on the safe and proper use of the equipment. Maintain these important safety features on the implement in good condition to ensure the information is available to the operator at all times.

- Ensure the manual canister is secured to the equipment with the operator's manual inside.
- Ensure all safety signs are in place and legible. Replace missing, damaged, and illegible decals. *OPS-U-0011*



OPERATION

Tractor PRE-OPERATION Inspection



Tractor ID# _____ Make _____

Date: _____ Shift _____



Before conducting the inspection, make sure the tractor engine is off, all rotation has stopped and the tractor is in park with the parking brake engaged. Make sure the mower is resting on the ground or securely blocked up and all hydraulic pressure has been relieved.

OPERATION

Item	Condition at Start of Shift	Specific Comments if not O.K.
The flashing lights function properly		
The SMV Sign is clean and visible		
The tires are in good condition with proper pressure		
The wheel lug bolts are tight		
The tractor brakes are in good condition		
The steering linkage is in good condition		
There are no visible oil leaks		
The hydraulic controls function properly		
The ROPS or ROPS Cab is in good condition		
The seatbelt is in place and in good condition		
The 3-point hitch is in good condition		
The drawbar pins are securely in place		
The PTO master shield is in place		
The engine oil level is full		
The brake fluid level is full		
The power steering fluid level is full		
The fuel level is adequate		
The engine coolant fluid level is full		
The radiator is free of debris		
The air filter is in good condition		

Operator's Signature: _____

DO NOT OPERATE an UNSAFE TRACTOR or MOWER

OPERATION

Tiller PRE-OPERATION Inspection



Tiller ID# _____ Make _____

Date: _____ Shift _____



Before conducting the inspection, make sure the tractor engine is off, all rotation has stopped and the tractor is in park with the parking brake engaged. Make sure the blade is resting on the ground or securely blocked up and all hydraulic pressure has been relieved.

Table 1:

Item	Condition at Start of Shift	Specific Comments if not O.K.
The Operator's Manual is in the Canister on the Tiller		
All Safety Decals are in place and legible.		
The Hitch connection bolts & pins are tight.		
There are no cracks in Hitch.		
The Tiller deck is clear of mud, dirt and debris		
Chain guards/Deflectors are in place & in good condition		
Driveline/Gearbox shields are in good condition		
Driveline clutches are in good condition, not frozen		
Driveline telescoping members & u-joints are lubricated		
Driveline yokes are securely attached to PTO & Tiller		
Gearbox mounting bolts are tight		
Gearbox oil is at the proper level		
Tiller shaft bearings bolts are tight		
Bearings are lubricated		
Tiller tines are not chipped, cracked or bent		
Tiller tines are tight		
Rear deflector shield is in place and in good condition		

Operator's Signature: _____

DO NOT OPERATE an UNSAFE TRACTOR or IMPLEMENT

OPERATION

OPERATION

8. OPERATING THE TRACTOR AND IMPLEMENT

THE OPERATOR MUST COMPLETELY UNDERSTAND HOW TO OPERATE THE TRACTOR AND IMPLEMENT AND ALL CONTROLS BEFORE ATTEMPTING TO OPERATE. The operator must read and understand the Safety and Operation Sections of the implement and tractor operator's manuals. These manuals must be read and explained to any operator who cannot read. Never allow someone to operate the implement and tractor without complete operating instructions.

Before starting any operation, the operator must become familiar with the area to be worked in and any obstacles and hazards contained within to ensure safety to the operator, bystanders, and equipment. Special attention should be paid to foreign debris, rough terrain, steep slopes, and passersby and animals in the area. *OPS-U- 0015*

▲WARNING

Many varied objects, such as wire, cable, rope, or chains, can become entangled in the rotating parts of the Implement. These objects could then swing outside the housing at greater velocities than the blades. Such a situation is extremely hazardous and could result in serious injury or even death. Inspect the area for such objects before working in the area. Remove any such objects from the site. Never allow the implement to contact such objects. (STL-6)

Foreign Debris Hazards

Before operating, inspect the area to make sure there are no foreign objects that the implement knives could hit or become entangled with. Remove all foreign objects and debris. If objects are too big to remove, mark them clearly and be sure to prevent the implement blades from contacting them.

If you hit a solid object or foreign debris, stop the implement and tractor at once. Immediately idle the engine speed and disengage the PTO. Wait for all implement rotating motion to stop, then raise the implement and move the tractor and implement off the object. Inspect the area and remove, or mark the location of the debris. Inspect the condition of the implement and make any needed repairs immediately. Make sure the knives are not damaged and the carrier is balanced before resuming operation.



Always wear your seat belt securely fastened and only operate the tractor and implement with the ROPS in the raised position. If the tractor or implement hits a tree stump, rock, or bump, a sudden movement could throw you off of the seat and under the tractor and/or implement. The seat belt is your best protection from falling off the tractor and the ROPS provides protection from being crushed during a tractor roll-over. *OPS-T-0003*

OPERATION

8.1 Adjusting the Tiller for work.

Adjustment Instructions

The REBEL Series Tillers depth of till is regulated by adjusting skids up or down., Average ground with reasonable moisture content will allow maximum depth in on pass with a ground speed between 2 and 5 mph operating the PTO speed at 540 RPM. Hard ground may require two passes to reach maximum depth.

The machine is equipped with an adjustable tailgate. The tailgate will regulate the finished results or tilth of the soil.

Traveling at the slowest forward speed with the tailgate fully lowered will give the finest possible finish. The fully lowered adjustment is good for mulching, mixing and burying weeds, fertilizer, etc.

The more you increase the forward speed and tailgate height, the coarser the finished results will be. To leave the ground surface rough with larger clods and residue exposed, work with tailgate fully raised. When working in rocky soil always have the tailgate raised.

Tailgate Adjustment

Adjustment is made by lowering or raising the tailgate and placing the adjusting chain in the slot of the retainer bracket behind the gearbox to maintain the desired tailgate position.



Retainer Bracket
Adjusting Chain

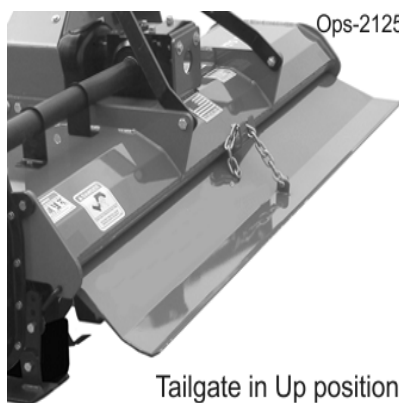

Tailgate in Up position

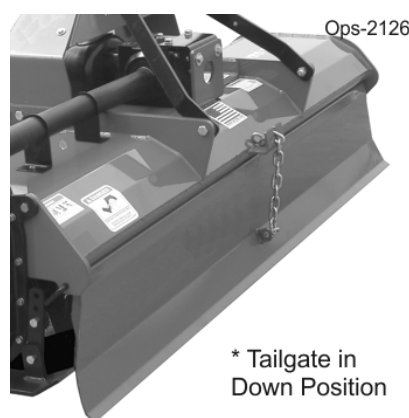

* Tailgate in Down Position



* Do not back up with the tailgate in the down position while the tiller is in the operating position. Raise the tiller off the ground so the tailgate clears the ground. Failure to do so will cause damage to the tailgate and tiller and possible injury to the operator.

8.2 Operating the Tiller

Operating Instructions

1. Before each use perform the maintenance described in maintenance section of this manual.
2. Read, understand, and follow the safety information on training, preparation, starting and stopping, operation, transportation, maintenance and storage.
3. With rotary tiller positioned on level ground, adjust the tractor arms so that when lifted, the rotor bar remains parallel to the ground.
4. With the rotary tiller attached to the tractor, raise and support the tiller with suitable blocks. Adjust the skids, located on the sides of the tiller. The adjustment bolts for both right and left sides should be positioned in the same adjustment hole. This allows the tiller to till the same depth on each side. Adjust the tailgate, with regulating chain, until the desired mulching effect is achieved.

OPERATION



Never attempt to adjust the rotary tiller while the tractor is running.

5. Raise the tiller and remove the blocks. Lower the tiller to the ground.
6. With the tractor at idle RPM and the tiller lifted off of the ground, engage PTO and slowly advance throttle to 540 PTO RPM.

NOTE: Rotary Tiller is designed to run at 540 PTO RPM ONLY.

7. Select a low gear for the tractor and begin to move forward. Tractor ground speed is to be controlled by gear selection only and not engine speed. As the tractor moves forward, slowly lower the tiller down. Allow the tiller tines to gradually engage the ground.

NOTE: Do NOT allow the tractor engine or rotary tiller to bog down or stall. This causes undue wear and tear on the tiller and tractor. If this continues to happen reduce ground speed and raise tilling depth of rotary tiller. Never attempt to remove objects from the rotor bar until the tractor has been shut down and the tiller tines have completely stopped.



Never travel at a fast ground speed while using the tiller. This could damage cause damage to the unit. Never turn the tractor or travel in reverse with the PTO engaged and tiller in the ground. Always raise the tiller out of the ground when backing up or attempting a turn. Failure to do so may cause damage to the tiller.

8. After each use clean all debris from the tiller tines. Replace any missing or illegible safety decals. Inspect for any damaged or worn parts and replace before next use. Store rotary tiller in a dry environment.



Extreme care should be taken when operating near loose objects such as gravel, rocks, wire, and other debris. Inspect the area before tilling. Foreign objects should be removed from the site to prevent machine damage and/or bodily injury or even death. Any objects that cannot be removed must be clearly marked and carefully avoided by the operator. Stop operating immediately if blades strike a foreign object. Repair all damage and make certain rotor and blades are in good condition before resuming operation. (STL-5)

8.3 Bystanders/Passersby Precautions

If a bystander comes within 300 feet of the tractor while the implement is being operated, stop the tractor at once, idle the engine and disengage the PTO. Do not engage the PTO again until all bystanders are well past the 300 foot distance. OPS-T-0004

8.4 Engaging the Power Take Off (PTO)

Before engaging the PTO, make certain that the area is clear of bystanders and passersby. The implement must be completely lowered and the deck positioned at a safe operating height. NEVER engage the PTO with the implement in the raised position.

Set the tractor engine speed at approximately 1,000 RPM before engaging the PTO. Shift the PTO control to the on position, and slowly increase the engine speed until the PTO is operating at the rated speed. If you hear unusual noises or see or feel abnormal vibrations, disengage the PTO immediately. Inspect the implement to determine the cause of the noise or vibration and repair the abnormality. OPS-U- 0027

OPERATION

DANGER

Do not put hands or feet under Tiller deck. Blade Contact can result in serious injury or even death. Stay away until all motion has stopped and the decks are securely blocked up. (STL-3)



8.5 PTO RPM and Ground Speed

Ground speed for operating will depend upon the type of cultivation. Recommended speed for efficient implement performance is between 2 and 5 mph. Operate the implement at its full rated PTO speed to maintain knife speed for a clean operation. Refer to the tractor operator's manual or the tractor instrument panel for the engine speed and gear to provide the required PTO and desired ground speed. Make sure that the implement is operating at its full rated speed before entering the area. If it becomes necessary to temporarily regulate engine speed, increase or decrease the throttle gradually.

Ground speed is achieved by transmission gear selection and not by the engine operating speed. The operator may be required to experiment with several gear range combinations to determine the best gear and range which provides the most ideal performance from the implement and most efficient tractor operation. As the severity of operating conditions increase, the ground speed should be decreased by selecting a lower gear to maintain the proper operating PTO speed. OPS-T-0006

WARNING

Do not exceed the rated PTO speed for the Implement. Excessive PTO speeds can cause Implement driveline or blade failures resulting in serious injury or death. (SG-26)

8.6 Shutting Down the Implement

To shut down the implement, first bring the tractor to a complete stop. Then slow down the implement by reducing the engine speed before disengaging the PTO. Wait for all motion to stop before proceeding to drive or shut down the tractor.

Park the tractor on a level surface, place the transmission in park or neutral and apply the parking brake, lower the attached implement to the ground, shut down the engine, remove the key, and wait for all motion to come to a complete stop before exiting the tractor. OPS-T-0007

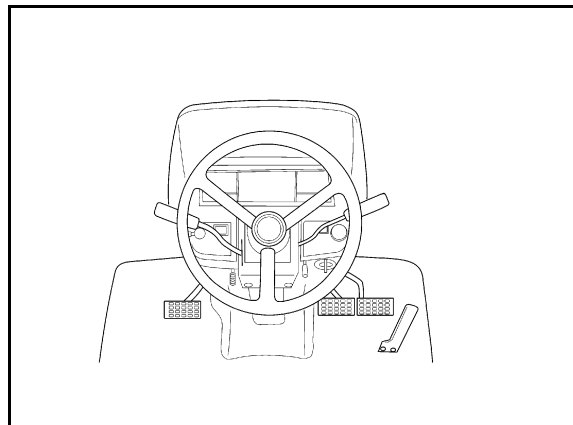

OPERATION

9. DISCONNECTING THE IMPLEMENT FROM THE TRACTOR

Before disconnecting the implement, the PTO must be disengaged and knife rotation at a complete stop. Move the implement to a level storage location and lower it to the ground. If the implement is not resting securely on the ground, block the implement up securely before attempting to disconnect it from the tractor.

Use extreme care to keep feet and hands from under the implement and clear of any pinch points caused by the tractor hitch arms and implement pins. *OPS-T-0008*



Never stand or allow another person to stand between a running Tractor and the Implement when disconnecting the Implement from the Tractor 3-point hitch.



Always shut the Tractor completely down, place the transmission in park, and set the parking brake before you or anyone else attempts to connect or disconnect the Implement and Tractor hitches. (S3PT-15)

To disconnect the implement, first extend the tractor 3-point hitch top link to remove tension on the top link hitch pin. When the pin is loose and easy to rotate, remove the pin from the implement. Next remove both lower hitch pins.

After disconnecting the 3-lift points, remove the implement driveline from the tractor PTO shaft. Lay the driveline down carefully to avoid damaging the driveline or its shield. Do not let the driveline fall into mud or dirt, which can contaminate the bearing and shorten the life of the driveline.

OPERATION

10. IMPLEMENT STORAGE

Properly preparing and storing the implement at the end of the season is critical to maintaining its appearance and to help ensure years of dependable service. The following are suggested storage procedures:

- Thoroughly clean all debris off the implement to prevent damage from rotting grass and standing water.
- Lubricate all implement grease points and fill gearbox oil levels as detailed in the maintenance section.
- Tighten all bolts and pins to the recommended torque.
- Check the implement for worn and damaged parts. Perform repairs and make replacements immediately so that the implement will be ready for use at the start of the next season.
- Store the implement in a clean, dry place with the implement housing resting securely on blocks or at ground level.
- Keep the driveline yoke from sitting in water, dirt and other contaminants.
- Use spray touch-up enamel where necessary to prevent rust and maintain the appearance of the implement.

It is critical that driveline clutches slip when an obstacle or heavy load is encountered to avoid implement and/or tractor damage. If the implement sits outside for an extended period of time or is exposed to rain and/or humid air, the clutch lining plates must be inspected to ensure they are not frozen together from rust or corrosion. If the implement has been exposed to such conditions, at the start of each operating season, and any time it is suspected that the slip clutch plates may be frozen together, readjust the slip clutch as detailed in Seasonal Clutch Maintenance of the maintenance section in this manual. *OPS-T-0010*



Never allow children or other persons to ride on the Tractor or Implement. Falling off can result in serious injury or death. (SG-10)



11. TRANSPORTING THE TRACTOR AND IMPLEMENT

Inherent hazards of operating the tractor and implement and the possibility of accidents are not left behind when you finish working in an area. Therefore, the operator must employ good judgement and safe operation practices when transporting the tractor and implement between locations. By using good judgement and following safe transport procedures, the possibility of accidents while moving between locations can be substantially minimized. *OPS-U-0017*

12. DRIVING THE TRACTOR AND IMPLEMENT

Safe tractor transport requires the operator possess a thorough knowledge of the model being operated and precautions to take while driving with an attached implement. Ensure the tractor has the capacity to handle the weight of the implement and the tractor operating controls are set for safe transport. To ensure safety while driving the tractor with an attached implement, review the following. *OPS-U-0012*



Never run the Tractor engine in a closed building or without adequate ventilation. The exhaust fumes can be hazardous to your health. (SG-23)

OPERATION

WARNING

Transport only at speeds where you can maintain control of the equipment. Serious accidents and injuries can result from operating this equipment at high speeds. Understand the Tractor and Implement and how it handles before transporting on streets and highways. Make sure the Tractor steering and brakes are in good condition and operate properly.



Before transporting the Tractor and Implement, determine the proper transport speeds for you and the equipment. Make sure you abide by the following rules:

Test the tractor at a slow speed and increase the speed slowly. Apply the Brakes smoothly to determine the stopping characteristics of the Tractor and Implement. As you increase the speed of the Tractor the stopping distance increases. Determine the maximum transport speed not to exceed 20 mph (30 kph) for transporting this equipment.

Test the equipment at a slow speed in turns. Increase the speed through the turn only after you determine that the equipment can be operated at a higher speed. Use extreme care and reduce your speed when turning sharply to prevent the tractor and implement from turning over. Determine the maximum turning speed for you and this equipment before operating on roads or uneven ground.

Only transport the Tractor and Implement at the speeds which allow you to properly control the equipment.

Be aware of the operating conditions. Do not operate the Tractor with weak or faulty brakes or worn tires. When operating down a hill or on wet or rain slick roads, the braking distance increases: use extreme care and reduce your speed. When operating in traffic always use the Tractor's flashing warning lights and reduce your speed. Be aware of traffic around you and watch out for the other guy. (SG-19)

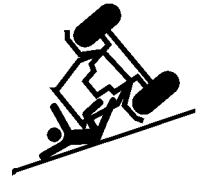

OPERATION

Before transporting the tractor and implement, idle the tractor engine, disengage the PTO and wait for all implement moving parts to come to a complete stop. Once all implement parts are completely stopped, raise the implement to transport height. **NOTE:** When raising the implement, maintain 1" clearance between the driveline and implement deck. If additional implement deck height is needed for transport, disconnect the driveline from the tractor and secure its end to the implement deck. The implement can then be raised to the maximum lift height. OPS-T-0011

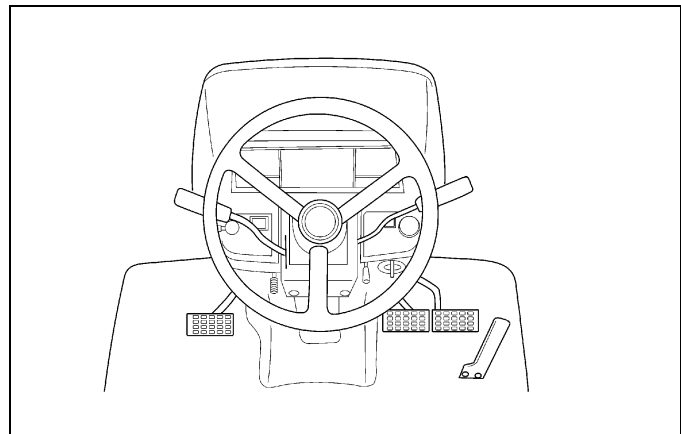

OPERATION

12.2 Transporting on Public Roadways

Extreme caution should be used when transporting the tractor and implement on public roadways. The tractor must be equipped with all required safety warning features including a SMV emblem and flashing warning lights to alert drivers of the tractor's presence. Remember that roadways are primarily designed for automotive drivers and most drivers will not be looking out for you, therefore, you must look out for them. Check your side view mirrors frequently and remember that vehicles will approach quickly because of the tractor's slower speed. Be extremely cautious when the piece of equipment that you are towing is wider than the tractor tire width and/or extends beyond your lane of the road.

Make sure that a proper size safety tow chain is secured between the tractor and implement before entering a public road. OPS-U- 0019



Make certain that the "Slow Moving Vehicle" (SMV) sign is installed in such a way as to be clearly visible and legible. When transporting the Equipment use the Tractor flashing warning lights and follow all local traffic regulations. (SG-6)

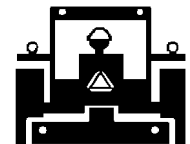

The SMV (Slow-Moving Vehicle) emblem is universal symbol used to alert drivers of the presence of equipment traveling on roadways at a slow speed. SMV signs are a triangular bright orange with reflective red trim for both easy day and night visibility. Make sure the SMV sign is clean and visible from the rear of the unit before transporting the tractor and implement on a public roadway. Replace the SMV emblem if faded, damaged, or no longer reflective. OPS-U- 0020



Op-43

Make sure that all tractor flashing warning lights, headlights, and brake/tail lights are functioning properly before proceeding onto public roads. While newer model tractors have plenty of lighting to provide warning signals and operating lighting, most older models are only equipped with operating lights. Consult an authorized tractor dealer for lighting kits and modifications available to upgrade the lighting on older tractor models. OPS-U- 0021



Op-595

OPERATION

When operating on public roads, have consideration for other road users. Pull to the side of the road occasionally to allow all following traffic to pass. Do not exceed the legal speed limit set in your country for agricultural tractors. Always stay alert when transporting the tractor and implement on public roads. Use caution and reduce speed if other vehicles or pedestrians are in the area. *OPS-T-0013*

Reduce speed before turning or applying the brakes. Ensure that both brake pedals are locked together when operating on public roads. *OPS-U- 0023*

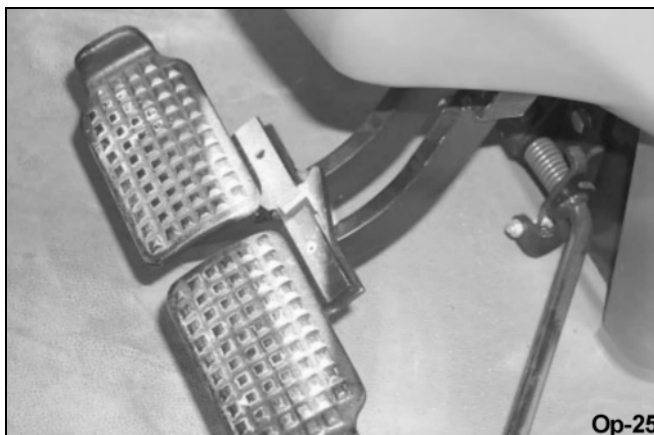

12.3 Hauling the Tractor and Implement

Before transporting a loaded tractor and implement, measure the height and width dimensions and gross weight of the complete loaded unit. Ensure that the load will be in compliance with the legal limits set for the areas that will be traveled through. *OPS-U- 0024*



OPERATION

Use adequately sized and rated trailers and equipment to transport the tractor and implement. Consult an authorized dealer to determine the proper equipment required. Using adequately sized chains, heavy duty straps, cables and/or binders, securely tie down both the front and rear of the tractor utilizing the proper tie down locations as specified by the tractor manufacturer. *OPS-U-0025*



OPERATION

OPERATION

13. TROUBLESHOOTING GUIDE

PROBLEM	POSSIBLE CAUSE	POSSIBLE REMEDY
Machine makes intermittent clicking noise	Loose knives Gear tooth damaged	Tighten knives Replace damaged gear
PTO Vibrates	Worn universal joint Machine lifted too high Excessive trash wrapped on rotor	Replace universal joint Lower machine and readjust tractor lift stop Remove trash
Gearbox noise is noticeable and constant	May be normal or new machine Low oil level Worn gears	Allow time for break-in Add oil Replace gears
Rotors stop turning	Slip clutch slipping Broken Gear / Gears	Reduce load to Tiller or Adjust slip clutch Replace Gears
Machine skip or leaves crop residue	Badly worn blades Slip clutch slipping Ground speed too fast for conditions	Replace worn blades Adjust slip clutch or reduce load Reduce ground speed
Machine smells hot or begins to smoke	Trash wrapped around drive components Low oil level in gearbox Slip clutch slipping	Remove trash Add oil Reduce load to machine or adjust slip clutch
Oil leaking from gearbox	Damaged seals Gearbox overfilled	Replace seals Drain to proper level (1/2 full)

OPERATION

MAINTENANCE SECTION

MAINTENANCE

Before operating your Tiller, make sure it is properly lubricated and thoroughly inspected. Only a minimum of time and effort is required to regularly lubricate and maintain this machine to provide long life and trouble free operation.



Always disengage the PTO before raising the Tiller for transporting or making adjustments.

LUBRICATION INFORMATION

Do not let excess grease collect on or around parts, particularly when operating in sandy areas. Severe or unusual conditions may require more frequent lubrication.

Use an SAE multi-purpose, lithium-type grease for all locations shown. Be sure to clean the fitting thoroughly before using grease gun.

Outboard Bearing Lubrication

Lubricate the Rotor Bearing Housing every 8 hours.

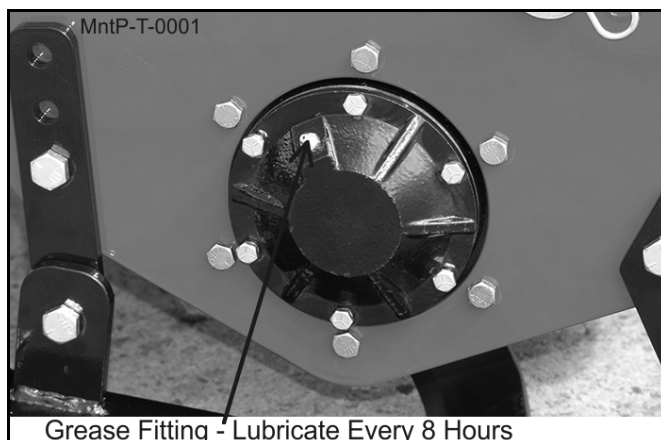

LUBRICATION

Before each use gearbox should be checked to be sure oil is at the proper levels. Operating the machine with the oil levels to low or to high can severely damage the machine. If it is determined that oil is needed follow these steps.

NOTE: Make sure the Gearbox is level prior to removing the Inspection Plug. Tilting forward may result in over filling. Tilting back may result in under filling. Use GL5-85W 140 or Triple Zero Grease which can be poured and has an "EP" Extreme Pressure Additive.

Top Gearbox

1. Remove the vent plug on the top of the gearbox and the small inspection plug at the rear of the gearbox.
2. Pour the gear oil into the vent plug hole slowly until the oil starts to come out of the small hole at the rear.
DO NOT OVERFILL THE GEARBOX.
3. Replace the small Inspection Plug and the Vent Plug. Clean up any excess gear oil.

MAINTENANCE

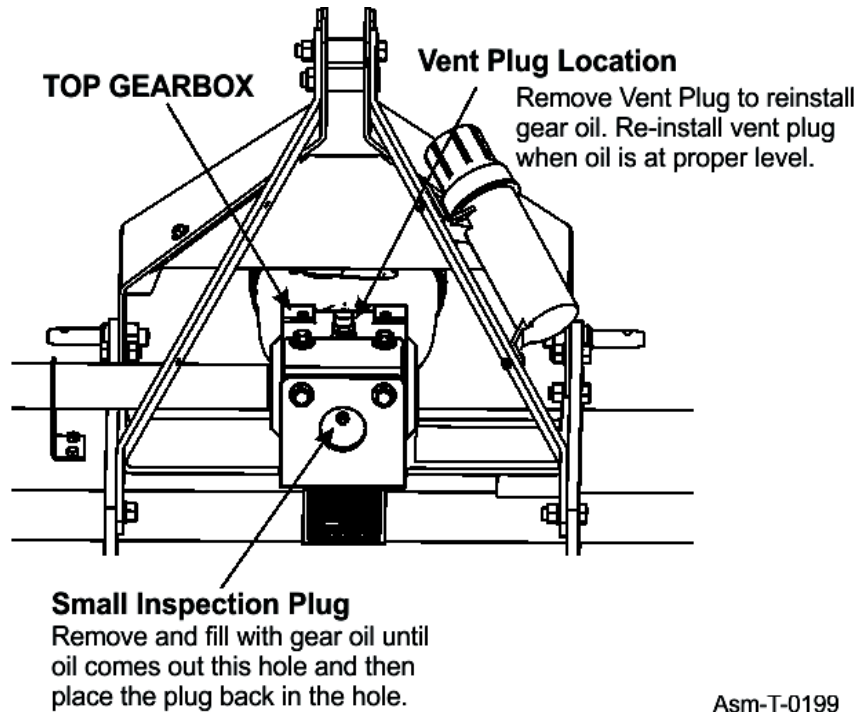

SIDE GEARBOX

1. Remove the vent plug on the top of the side gearbox and the small inspection plug at the side of the gearbox.
2. Pour the gear oil into the vent plug hole slowly until the oil starts to come out of the small hole on the side. **DO NOT OVERFILL THE GEARBOX.**
3. Replace the small Inspection Plug and the Vent Plug. Clean up any excess gear oil.

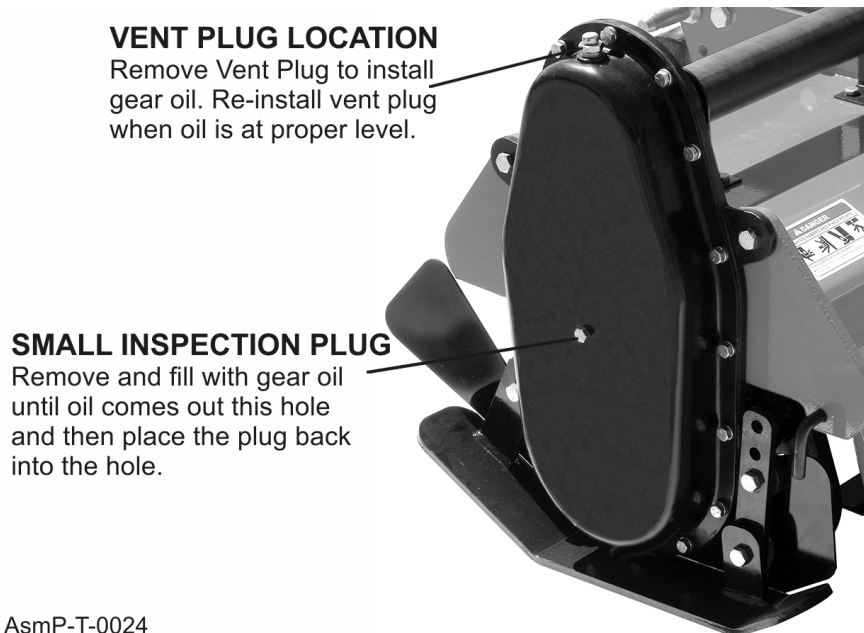

MAINTENANCE

MAINTENANCE

DRIVESHAFT LUBRICATION

Grease fittings are located on the cross assembly of each U-Joint and on the telescoping tubes. Grease the U-Joint after each 8 hours of use. Do not force grease through the needle cup assemblies. Grease the telescoping tubes after every 8 hours use. Lubricate the shield bearings every 16 hours.

Universal Joint

Apply Multi-Purpose Grease to the Universal Joint on each end of the driveshaft every 8 hours of use. Do not force grease through the needle cup assemblies.

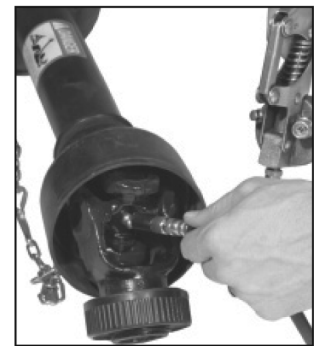
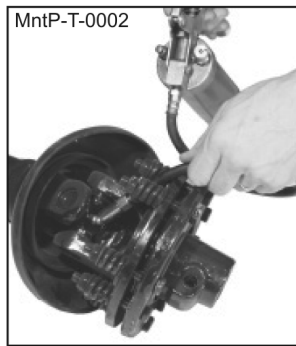

Shields

Apply 2-3 shots of Multi Purpose Grease to the safety shield on each end of the driveshaft.

The Driveshaft Integral Shields should not become dented or otherwise damaged. The Integral Shield Assembly has a Nylon Bearing at each end and should turn freely. This nylon bearing should require lubrication every 16 hours.

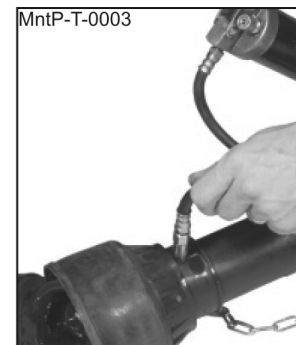

Telescoping Tubes

Grease the telescoping tubes after every 8 hours use. Separate the driveshaft and apply grease to the inner shaft surface.



IMPORTANT: Scan this QR Code with your smart phone to link to the ADMA Driveline Safety Manual for more information on the safe use of a driveline during normal operation and maintenance. Or type in your internet browser the following web address: www.algqr.com/dme *Ops-0009-MISC*



MAINTENANCE

SLIP CLUTCHES

A Slip Clutch is incorporated in the PTO driveline. It is designed to slip, absorb the shock load, and protect the driveline.

Clutch torque setting is factory set. If clutch slips excessively, check friction discs for excessive wear. Discs are 1/8" thick when new. Replace after 1/32" wear.

To adjust slip clutch, first check length of springs as assembled on clutch. Length should be 1 inch. If not, adjust length of bolt to obtain proper spring length. If additional adjustment is required, tighten each bolt 1/2 turn.

NOTE! DO NOT tighten spring bolts over 1/2 turn at any adjustment. Excessive tightening can cause clutch to become frozen and not slip which could cause damage to tractor PTO, Driveline, or Gearbox.

Avoid overheating of clutches caused by too long or too frequent slipping of the clutch since this can damage the friction plates and clutch parts. When checking slip clutch for overheating, do not touch with hand. Clutch could be extremely hot and cause severe burn.

SEASONAL CLUTCH MAINTENANCE

It is important that the clutches slip when an obstacle or load heavier than the clutch setting is encountered. Before using the implement each season, use the following procedure to make sure the clutch will slip and give the overload protection required.

1. Loosen nuts (1) until the spring is free, and then re-tighten approximately one turn.
2. Attach machine to tractor, set engine at approximately half throttle and quickly engage PTO for two or three seconds, then disengage. This procedure will break clutch facings loose and allow the proper torque to be maintained.
3. Return the nuts and bolts to their original position of 1.10" (28mm) compressed spring length.

NOTE: If machine sits outside longer than 30 days and is exposed to rain and humid air, the clutches should be removed from machine and stored in dry area. Clutch facings will soak up moisture and cause the metal plates to rust badly. When this occurs, the break-away torque increases greatly and damage to gearbox, driveline, or tractor PTO can occur.

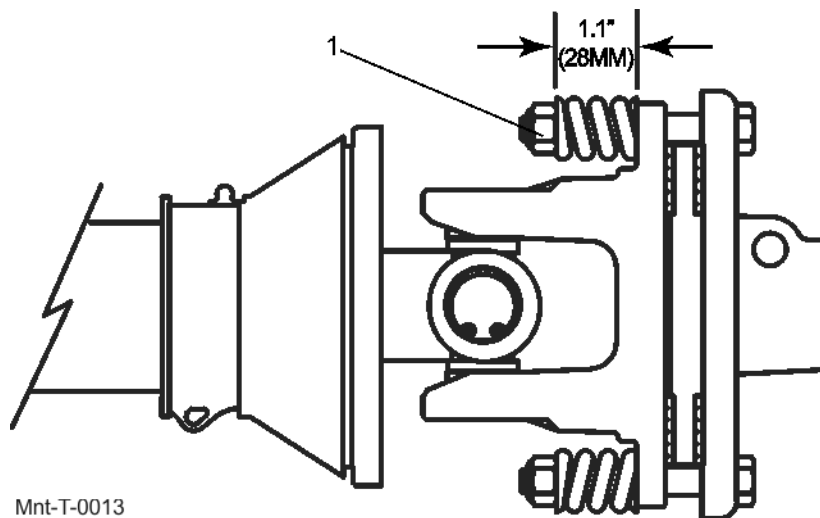

Mnt-T-0013

MAINTENANCE

GENERAL MAINTENANCE

Blades

Owner / Operator should routinely check the machine for broken and severely worn blades and replace as necessary to keep the tiller in its best working condition.

Fasteners

Check the tiller for loose pins, bolts, or broken fasteners and tighten or replace as necessary. Refer to proper Bolt Torque chart supplied in this manual for proper torque settings of fasteners.

Safety Devices

Make sure all Safety Shields and Guards are in place and in good working order.

Check to be sure all Safety Decals are in place and legible. Replace if needed.

STORAGE

Your implement tiller represents an investment from which you should get the greatest possible benefit. Therefore, when the season is over, the tiller should be thoroughly checked and prepared for storage so that a minimum amount of work will be required to put it back into operation for the next season.

The following are suggested storage procedures:

1. Thoroughly clean the tiller.
2. Lubricate the tiller as covered in Maintenance Section.
3. Tighten all bolts and pins to the recommended torque.
4. Check the tiller for worn or damaged parts. Make replacements immediately.
5. Store the tiller in a clean, dry place.
6. Use spray touch-up enamel where necessary to prevent rust and maintain the appearance of the tiller.
7. Store unit away from human activity.
8. Do not park equipment where it can be exposed to direct contact to livestock, which could result to damage of machine or livestock.
9. Make sure to park the machine on a hard, level surface and engage safety devices.

PROPER TORQUE FOR FASTENERS

The chart lists the correct tightening torque for fasteners. When bolts are to be tightened or replaced, refer to this chart to determine the grade of bolts and the proper torque except when specific torque values are assigned in manual text.

RECOMMENDED TORQUE IN FOOT POUNDS UNLESS OTHERWISE STATED IN THE MANUAL *

NOTE: These values apply to fasteners as received from supplier, dry or when lubricated with normal engine oil. They do not apply if special graphited or molydisulphide greases or other extreme pressure lubricants are used. This applies to both UNF fine and UNC coarse threads.

MAINTENANCE

MAINTENANCE

TORQUE SPECIFICATIONS - DRY TORQUE

Proper torque for American fasteners.
Recommended Torque in Foot Pounds (Newton Meters).*

AMERICAN Bolt Head Markings

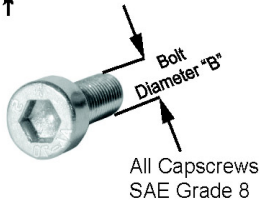
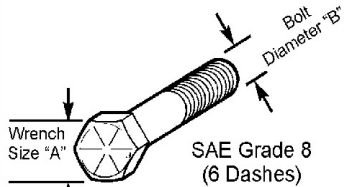

WRENCH SIZE (IN.) "A"	BOLT DIAMETER (IN.) "B" AND THREAD SIZE	SAE GRADE 2	SAE GRADE 5	SAE GRADE 8
7/16	1/4 - 20 UNC	6 (7)	8 (11)	12 (16)
7/16	1/4 - 28 UNF	6 (8)	10 (13)	14 (18)
1/2	5/16 - 18 UNC	11 (15)	17 (23)	25 (33)
1/2	5/16 - 24 UNF	13 (17)	19 (26)	27 (37)
9/16	3/8 - 16 UNC	20 (27)	31 (42)	44 (60)
9/16	3/8 - 24 UNF	23 (31)	35 (47)	49 (66)
5/8	7/16 - 14 UNC	32 (43)	49 (66)	70 (95)
5/8	7/16 - 20 UNF	36 (49)	55 (75)	78 (106)
3/4	1/2 - 13 UNC	49 (66)	76 (103)	106 (144)
3/4	1/2 - 20 UNF	55 (75)	85 (115)	120 (163)
7/8	9/16 - 12 UNC	70 (95)	109 (148)	153 (207)
7/8	9/16 - 18 UNF	79 (107)	122 (165)	172 (233)
15/16	5/8 - 11 UNC	97 (131)	150 (203)	212 (287)
15/16	5/8 - 18 UNF	110 (149)	170 (230)	240 (325)
1-1/8	3/4 - 10 UNC	144 (195)	266 (360)	376 (509)
1-1/8	3/4 - 16 UNF	192 (260)	297 (402)	420 (569)
1-5/16	7/8 - 9 UNC	166 (225)	430 (583)	606 (821)
1-5/16	7/8 - 14 UNF	184 (249)	474 (642)	668 (905)
1-1/2	1 - 8 UNC	250 (339)	644 (873)	909 (1232)
1-1/2	1 - 12 UNF	274 (371)	705 (955)	995 (1348)
1-1/2	1 - 14 UNF	280 (379)	721 (977)	1019 (1381)
1-11/16	1-1/8 - 7 UNC	354 (480)	795 (1077)	1288(1745)
1-11/16	1-1/8 - 12 UNF	397 (538)	890 (1206)	1444 (1957)
1-7/8	1-1/4 - 7 UNC	500 (678)	1120 (1518)	1817 (2462)
1-7/8	1-1/4 - 12 UNF	553 (749)	1241 (1682)	2013 (2728)
2-1/16	1-3/8 - 6 UNC	655 (887)	1470 (1992)	2382 (3228)
2-1/16	1-3/8 - 12 UNF	746 (1011)	1672 (2266)	2712 (3675)
2-1/4	1-1/2 - 6 UNC	870 (1179)	1950 (2642)	3161 (4283)
2-1/4	1-1/2 - 12 UNF	979 (1327)	2194 (2973)	3557 (4820)

METRIC

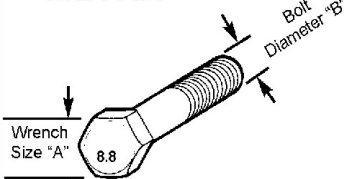

Numbers appearing on bolt heads indicate ASTM class.

Proper torque for Metric fasteners.
Recommended torque in Foot Pounds (Newton Meters).*

WRENCH SIZE (mm) "A"	BOLT DIA. (mm) "B"	ASTM 4.6	ASTM 8.8	ASTM 9.8	ASTM 10.9
8	5	1.8 (2.4)		5.1 (6.9)	6.5 (8.8)
10	6	3 (4)		8.7 (12)	11.1 (15)
13	8	7.3 (10)		21.1 (29)	27 (37)
16	10	14.5 (20)		42 (57)	53 (72)
18	12	25 (34)	74 (100)	73 (99)	93 (126)
21	14	40 (54)	118 (160)	116 (157)	148 (201)
24	16	62 (84)	167 (226)	181 (245)	230 (312)
30	20	122 (165)	325 (440)		449 (608)
33	22		443 (600)		611 (828)
36	24	211 (286)	563 (763)		778 (1054)
41	27		821 (1112)		1138 (1542)
46	30	418 (566)	1119 (1516)		1547 (2096)

*Use 75% of the specified torque value for plated fasteners. Use 85% of the specified torque values for lubricated fasteners.

Mnt-B-0005

RHINO

LIMITED WARRANTY

1. LIMITED WARRANTIES

- 1.01. Rhino warrants for one year from the purchase date to the original non-commercial, governmental, or municipal purchaser ("Purchaser") and warrants for six months to the original commercial or industrial purchaser ("Purchaser") that the goods purchased are free from defects in material or workmanship.
- 1.02. Manufacturer will replace for the Purchaser any part or parts found, upon examination at one of its factories, to be defective under normal use and service due to defects in material or workmanship.
- 1.03. This limited warranty does not apply to any part of the goods which has been subjected to improper or abnormal use, negligence, alteration, modification, or accident, damaged due to lack of maintenance or use of wrong fuel, oil, or lubricants, or which has served its normal life. This limited warranty does not apply to any part of any internal combustion engine, or expendable items such as blades, shields, guards, or pneumatic tires except as specifically found in your Operator's Manual.
- 1.04. Except as provided herein, no employee, agent, Dealer, or other person is authorized to give any warranties of any nature on behalf of Manufacturer.

2. REMEDIES AND PROCEDURES.

- 2.01. This limited warranty is not effective unless the Purchaser returns the Registration and Warranty Form to Manufacturer within 30 days of purchase.
- 2.02. Purchaser claims must be made in writing to the Authorized Dealer ("Dealer") from whom Purchaser purchased the goods or an approved Authorized Dealer ("Dealer") within 30 days after Purchaser learns of the facts on which the claim is based.
- 2.03. Purchaser is responsible for returning the goods in question to the Dealer.
- 2.04. If after examining the goods and/or parts in question, Manufacturer finds them to be defective under normal use and service due to defects in material or workmanship, Manufacturer will:
 - (a) Repair or replace the defective goods or part(s) or
 - (b) Reimburse Purchaser for the cost of the part(s) and reasonable labor charges (as determined by Manufacturer) if Purchaser paid for the repair and/or replacement prior to the final determination of applicability of the warranty by Manufacturer.

The choice of remedy shall belong to Manufacturer.

- 2.05. Purchaser is responsible for any labor charges exceeding a reasonable amount as determined by Manufacturer and for returning the goods to the Dealer, whether or not the claim is approved. Purchaser is responsible for the transportation cost for the goods or part(s) from the Dealer to the designated factory.

3. LIMITATION OF LIABILITY.

- 3.01. MANUFACTURER DISCLAIMS ANY EXPRESS (EXCEPT AS SET FORTH HEREIN) AND IMPLIED WARRANTIES WITH RESPECT TO THE GOODS INCLUDING, BUT NOT LIMITED TO, MERCHANTABILITY AND FITNESS FOR A PARTICULAR PURPOSE.
- 3.02. MANUFACTURER MAKES NO WARRANTY AS TO THE DESIGN, CAPABILITY, CAPACITY, OR SUITABILITY FOR USE OF THE GOODS.
- 3.03. EXCEPT AS PROVIDED HEREIN, MANUFACTURER SHALL HAVE NO LIABILITY OR RESPONSIBILITY TO PURCHASER OR ANY OTHER PERSON OR ENTITY WITH RESPECT TO ANY LIABILITY, LOSS, OR DAMAGE CAUSED OR ALLEGED TO BE CAUSED DIRECTLY OR INDIRECTLY BY THE GOODS INCLUDING, BUT NOT LIMITED TO, ANY INDIRECT, SPECIAL, CONSEQUENTIAL, OR INCIDENTAL DAMAGES RESULTING FROM THE USE OR OPERATION OF THE GOODS OR ANY BREACH OF THIS WARRANTY. NOT WITHSTANDING THE ABOVE LIMITATIONS AND WARRANTIES, MANUFACTURER'S LIABILITY HEREUNDER FOR DAMAGES INCURRED BY PURCHASER OR OTHERS SHALL NOT EXCEED THE PRICE OF THE GOODS.
- 3.04. NO ACTION ARISING OUT OF ANY CLAIMED BREACH OF THIS WARRANTY OR TRANSACTIONS UNDER THIS WARRANTY MAY BE BROUGHT MORE THAN TWO (2) YEARS AFTER THE CAUSE OF ACTION HAS OCCURRED.

4. MISCELLANEOUS.

- 4.01. Proper Venue for any lawsuits arising from or related to this limited warranty shall be only in Guadalupe County, Texas.
- 4.02. Manufacturer may waive compliance with any of the terms of this limited warranty, but no waiver of any terms shall be deemed to be a waiver of any other term.
- 4.03. If any provision of this limited warranty shall violate any applicable law and is held to be unenforceable, then the invalidity of such provision shall not invalidate any other provisions herein.
- 4.04. Applicable law may provide rights and benefits to purchaser in addition to those provided herein.

KEEP FOR YOUR RECORDS

ATTENTION: Purchaser should fill in the blanks below for his reference when buying repair parts and/or for proper machine identification when applying for warranty.

Rhino Implement Model _____ Serial Number _____

Date Purchased _____ Dealer _____

ATTENTION:

READ YOUR OPERATOR'S MANUAL

RHINO®

1020 S Sangamon Ave.

Gibson City, IL 60936

800-446-5158

Email: parts@servis-rhino.com





TO THE OWNER/OPERATOR/DEALER

To keep your implement running efficiently and safely, read your manual thoroughly and follow these directions and the Safety Messages in this Manual. The Table of Contents clearly identifies each section where you can easily find the information you need.

The OCCUPATIONAL SAFETY AND HEALTH ACT (1928.51 Subpart C) makes these minimum safety requirements of tractor operators:

REQUIRED OF THE OWNER:

1. Provide a Roll-Over-Protective Structure that meets the requirements of this Standard; and
2. Provide Seat belts that meet the requirements of this paragraph of this Standard and SAE J4C; and
3. Ensure that each employee uses such Seat belt while the tractor is moving; and
4. Ensure that each employee tightens the Seat belt sufficiently to confine the employee to the protected area provided by the ROPS

REQUIRED OF THE OPERATOR:

1. Securely fasten seat belt if the tractor has a ROPS.
2. Where possible, avoid operating the tractor near ditches, embankments, and holes.
3. Reduce speed when turning, crossing slopes, and on rough, slick, or muddy surfaces.
4. Stay off slopes too steep for safe operation.
5. Watch where you are going - especially at row ends, on roads, and around trees.
6. Do not permit others to ride.
7. Operate the tractor smoothly - no jerky turns, starts, or stops.
8. Hitch only to the drawbar and hitch points recommended by the tractor manufacturer.
9. When the tractor is stopped, set brakes securely and use park lock, if available.

-
- x Keep children away from danger all day, every day...
 - x Equip tractors with rollover protection (ROPS) and keep all machinery guards in place...
 - x Please work, drive, play and live each day with care and concern for your safety and that of your family and fellow citizens.



**REB60, REB60R
REB72R, REB72R
REB84, REB84R
REBEL TILLER**

REBEL TILLER-SOM-04/16
Printed U.S.A

P/N 50075545