

ITEM NO.	QTY.	PART No	DESCRIPTION	DRAWING No	WEIGHT kg	VENDOR	VENDOR No
1	1	GM36-500	GM 360 DECK FABRICATION	GM36 - 500	632.12		
2	1	GMC-904	GEARMOWER HEADSTOCK	GMC - 904	29.39		
3	2	LPB216	HEAVY DUTY PIN - 105	Purchased	0.70	Bare Co	B216
4	2	LP10D	10mm LYNCH PIN	Purchased	0.05	Bare Co	B6
5	2	GMC-905	GEARMOWER WHEEL & ARM	GMC - 905	58.89		
6	18	HHB3/4UNF-16T3	3/4" UNF x 3" HEX BOLT	Purchased	0.23	MAPTCO	TBA
7	18	HNN3/4UNF	3/4" UNF HEX NYLOC NUT	Purchased	0.06	MAPTCO	TBA
8	18	WF20MHT	M20 HIGH TENSILE FLAT WASHER	Purchased	0.02	TBA	TBA
9	4	GMC-002	CHAIN GUARD	GMC - 02	9.74		
10	2	GM36-012	CHAIN GUARD MID	GM36 - 12	14.10		
11	24	HHB40M12	M12 x 40 HEX HEAD BOLT	Purchased	0.05	TBA	TBA
12	24	HNN12M	M12 NYLOC NUT	Purchased	0.02	TBA	TBA
13	24	WF12M	M12 FLAT WASHER	Purchased	0.01	TBA	TBA
14	2	DSHC13	13mm D-Shackle	Purchased	0.23	TBA	TBA
15	2	GMC-009	HEADSTOCK CHAIN	GMC - 09	5.24		
16	2	GMC-502	SKID - 1100	GMC - 502	51.15		
17	8	HHB50M16	M16 x 50 HEX BOLT	Purchased	0.12	TBA	TBA
18	8	HNN16M	M16 HEX HEAD NUT	Purchased	0.04	TBA	TBA
19	8	WF16M	M16 FLAT WASHER	Purchased	0.01	TBA	TBA
20	8	SW16	M16 SP WASHER ZN PL	Purchased	0.00	TBA	TBA
21	146	LS80_23	CHAIN - GUARD	LS80 - 23	0.44		
22	2	GM36-017	CHAIN RETAINER ROPE	GM36 - 17	0.93		
23	3	GM36-901	470mm GM BLADE CARRIER ASSY	GM36 - 901	28.18		
24	4	DRV050	HEAVY DUTY COVER MOUNT	DRV - 50	1.52		
25	2	GM36-016	GM 360 G.BOX CONNECT COVER	GM36 - 16	8.64		
26	16	HHB25M10	M10 x 40 HEX HEAD BOLT	Purchased	0.03	TBA	TBA
27	16	SW10	M10 SPRING WASHER ZN PL	Purchased	0.00	TBA	TBA
28	16	WF10M	M10 FLAT WASHER	Purchased	0.00	TBA	TBA
29	20	HHB5_16UNC-18T3/4	5/16UNC x 3/4 HEX BOLT	Purchased	0.01	MAPTCO	TBA
30	4	1060L	LH SLASHER BLADE 408mm	Purchased	2.80	PRATCO	SBH 415
31	2	1060R	RH SLASHER BLADE 408mm	Purchased		PRATCO	SBH 416
32	1	GM36-600	GEARBOX DRIVE ASSEMBLY	GM36 - 600	438.26		
33	4	UCLP8mm	8mm U-CLAMP	Purchased	0.08	TBA	TBA
34	11	HNN8M	M8 NYLOC NUT	Purchased	0.01	TBA	TBA
35	1	ENC001	DOCUMENT HOLDER	Purchased	0.64	Bare Co	B1970
36	3	HHB25M8	M8 x 25 HEX BOLT	Purchased	0.02	TBA	TBA
37	3	WF8M	M8 FLAT WASHER	Purchased	0.00	TBA	TBA

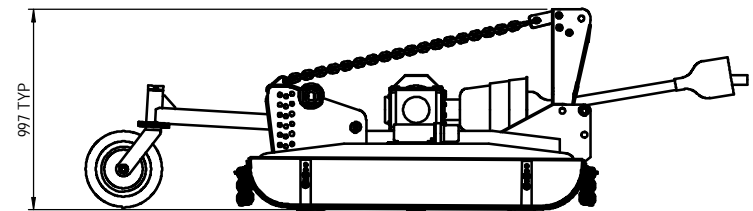

REAR

RIGHT SIDE

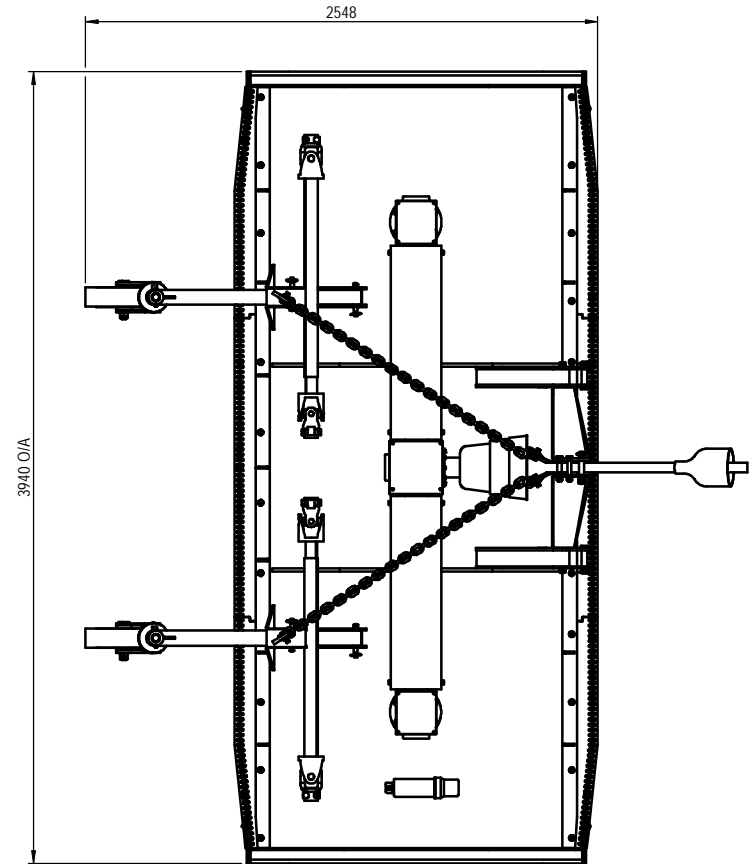
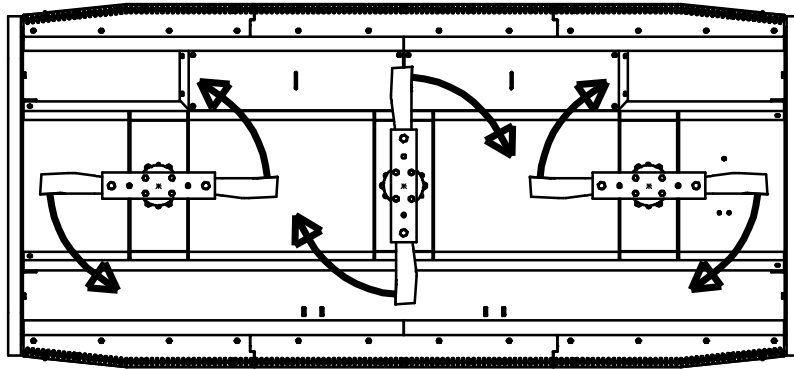

LEFT SIDE

FRONT

DO NOT SCALE
IF IN DOUBT - ASK

No.	Description	DWN	CHK	APPD	DATE
PT	PRELIMINARY DRAWING	-	-	-	-
A	APPROVED FOR CONSTRUCTION	-	-	-	-
B	GENERAL REVISION AND TIDY UP	AWP	WP	WP	29.12.16

199 Bridge Street, Oakay, Qld, 4401

THIS DRAWING IS PRIVATE AND CONFIDENTIAL AND REMAINS THE PROPERTY OF FIELDQUIP. RETURNED UPON REQUEST. IT MUST NOT BE COPIED OR LOANED WITHOUT THE CONSENT OF FIELDQUIP.

SCALE	1:25	U.N.O
Design	D.M.	-
Drawn	MG	04.06.15
Check	AWP	04.06.15
Appd.	D.M.	04.06.15

150HP GEARMOWER 360 ASSY

150HP GEARMOWER 360 SERIES

3rd ANGLE PROJECTION U.N.O.	A3
Fieldquip Drawing Number	REV
GM36 - 900	B

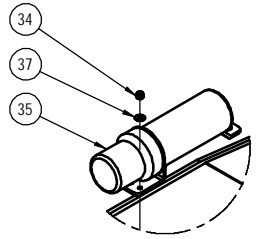

DETAIL C (1 : 10)

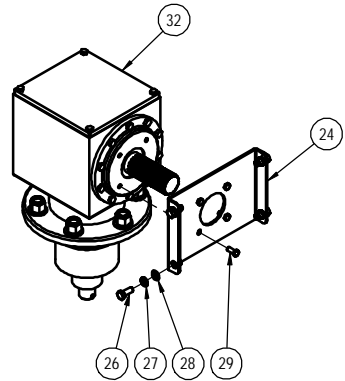

DETAIL A (1 : 10)

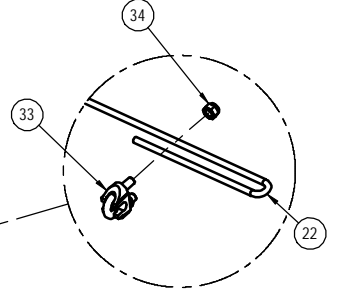
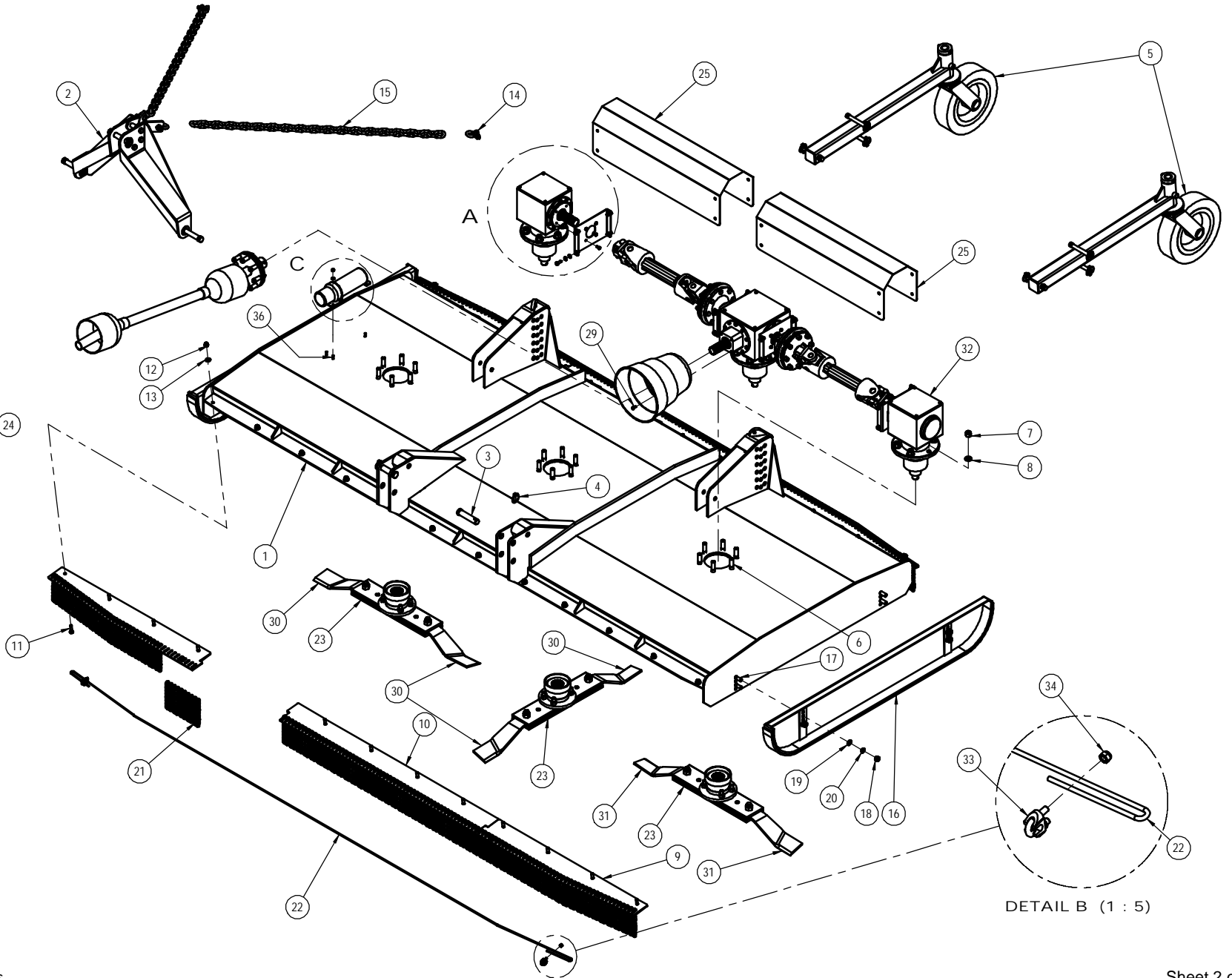

DETAIL B (1 : 5)

DO NOT SCALE
IF IN DOUBT - ASK WEIGHT 1600914.8 GMS

199 Bridge Street, Oakley, Qld, 4401

Sheet 2 of 2

No.	Description	DWN	CHK	APPD	DATE
P1	PRELIMINARY DRAWING	-	-	-	-
A	APPROVED FOR CONSTRUCTION	-	-	-	-
B	GENERAL REVISION AND TIDY UP	AWP	WP	WP	29.12.16

THIS DRAWING IS PRIVATE AND CONFIDENTIAL AND REMAINS THE PROPERTY OF FIELDQUIP. RETURNED UPON REQUEST. IT MUST NOT BE COPIED OR LOANED WITHOUT THE CONSENT OF FIELDQUIP.

SCALE	1:20	U.N.O
Design	D.M.	-
Drawn	MG	04.06.15
Check	AWP	04.06.15
Appd.	D.M.	04.06.15

150HP GEARMOWER 360 ASSY

150HP GEARMOWER 360 SERIES

3rd ANGLE PROJECTION U.N.O.		A3
Fieldquip	Drawing Number	REV
GM36 - 900		B

ITEM NO.	QTY.	PART No	DESCRIPTION	DRAWING No	VENDOR	VENDOR No
1	1	GC - 36	DRIVE KIT (Bare Co - TBA)	GC - 36	Bare Co	TBA
2	2	GM36-601	150HP INTERCONNECTING SHAFT	GM36 - 601		

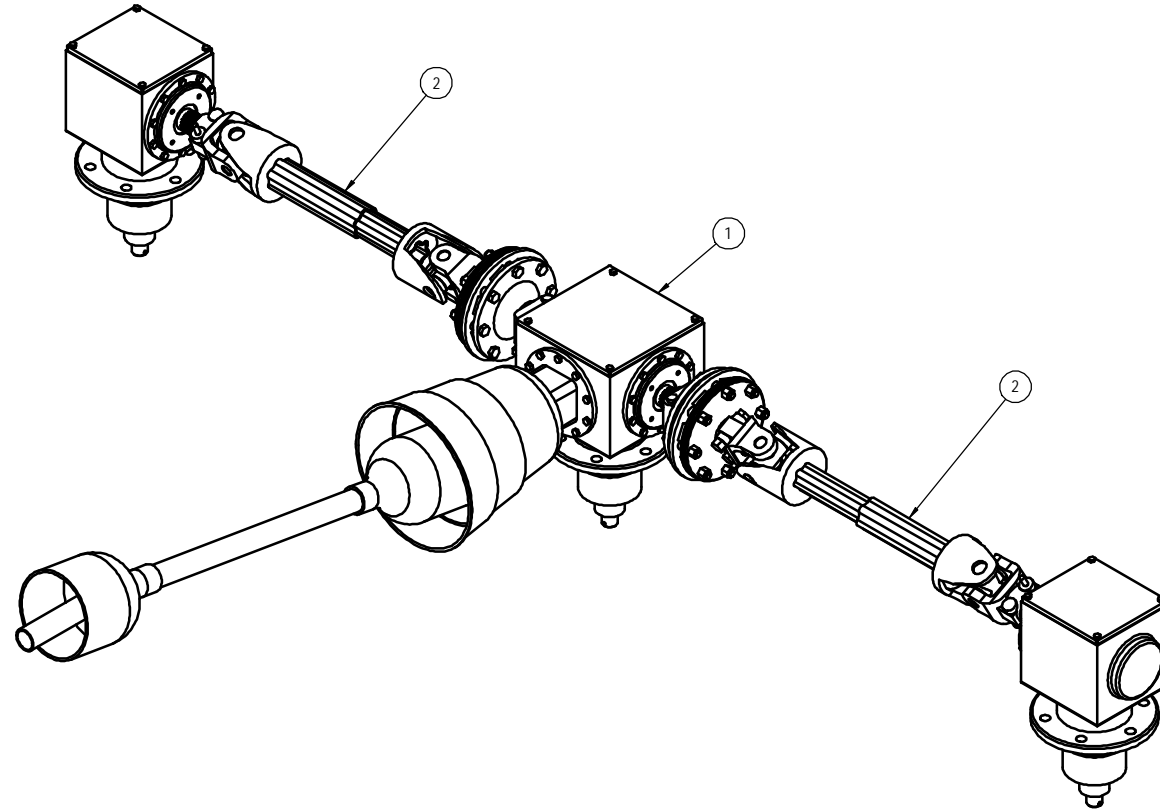

DO NOT SCALE
IF IN DOUBT - ASK WEIGHT 438255.5 GMS

199 Bridge Street, Oakay, Qld, 4401

Sheet 1 of 1

No.	Description	DWN	CHK	APPD	DATE
P1	PRELIMINARY DRAWING	-	-	-	-
A	APPROVED FOR CONSTRUCTION	-	-	-	-

FIELDQUIP

Australian owned family business
 THIS DRAWING IS PRIVATE AND CONFIDENTIAL AND REMAINS THE PROPERTY OF FIELDQUIP.
 RETURNED UPON REQUEST. IT MUST NOT BE COPIED OR LOANED WITHOUT THE CONSENT OF FIELDQUIP.

SCALE	1:10	U.N.O
Design	DM	-
Drawn	AWP	26.12.16
Check	WP	09.01.17
Appd.	WP	09.01.17

GEARBOX DRIVE ASSEMBLY

GEARMOWER 360 SERIES

3rd ANGLE PROJECTION U.N.O.		A3
Fieldquip	Drawing Number	REV
GM36 - 600		A

ITEM NO.	QTY.	PART NUMBER	DRAWING NUMBER	WEIGHT IN kg	DESCRIPTION
1	1	GM36-001	GM36 - 01	259.3	CUTTER DECK
2	4	GMC-023	GMC - 23	9.1	OUTER LIFT PLATE
3	2	HSM015	HSM - 15	2.8	LIFT PLATE GUSSET
4	2	GMC-022	GMC - 22	10.6	CASTOR WHEEL BRACKET - LH
5	2	GMC-021	GMC - 21	10.6	CASTOR WHEEL BRACKET - RH
6	2	GMC-012	GMC - 12	1.4	CHAIN MOUNT PLATE
7	2	GMC-015	GMC - 15	30.3	DECK SIDE STIFFENER PLATE
8	2	GM36-005	GM36 - 05	20.9	CHAIN GUARD SUPPORT
9	4	GM36-006	GM36 - 06	15.4	CHAIN GUARD MOUNT PLATE
10	2	GM36-004	GM36 - 04	12.8	DECK STIFFENER
11	3	GMC-016	GMC - 16	13.8	DECK GEARBOX STIFFENER
12	2	GM36-008	GM36 - 08	17.4	UNDER DECK SUPPORT
13	2	GMC-010	GMC - 10	0.3	CHAIN ANCHOR POINT
14	3	GMC-017	GMC - 17	1.2	UNDER DECK SPACER
15	2	GMC-018	GMC - 18	0.5	GRASS PLATE SUPPORT
16	4	GMC-019	GMC - 19	0.8	SKID PLATE GUSSET
17	12	XTR90-014	XTR90 - 14	0.2	SIDE PLATE CENTRE GUSSET
18	2	GM36-002	GM36 - 02	5.0	GRASS DEFLECTOR

ALL WELDS 6 CFW UNO

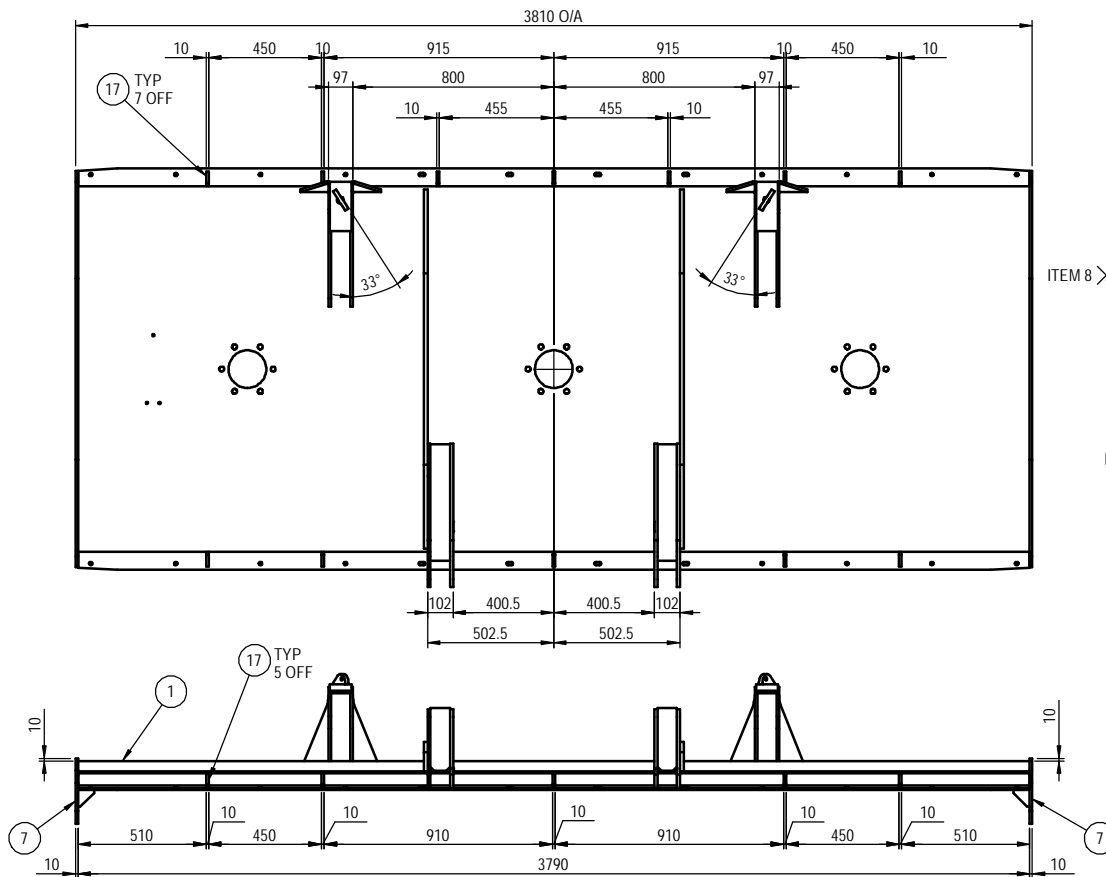

199 Bridge Street, Oakley, Qld, 4401

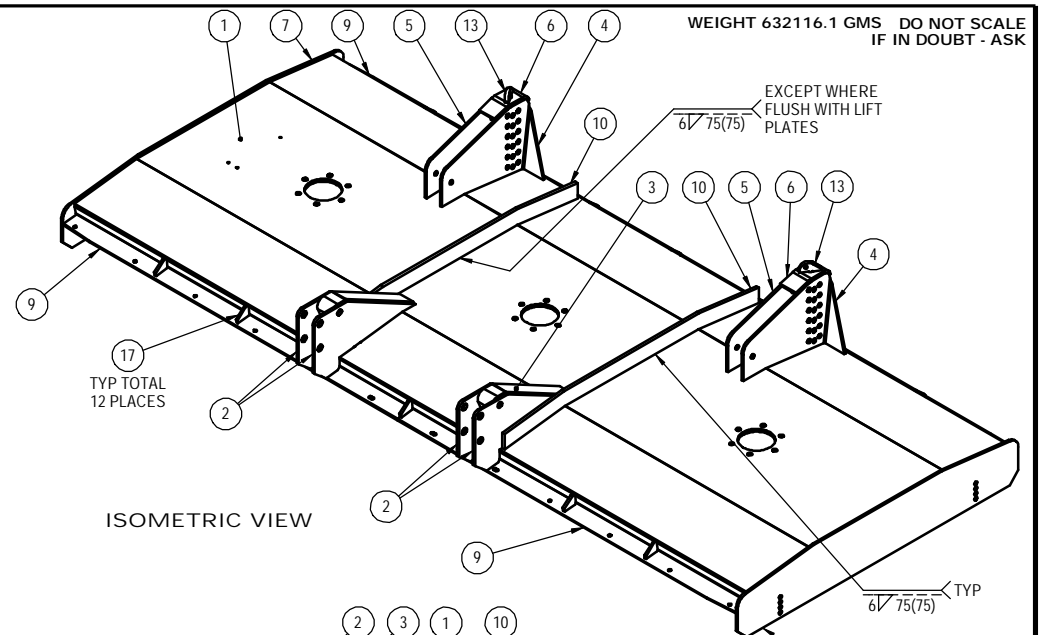

ISOMETRIC VIEW

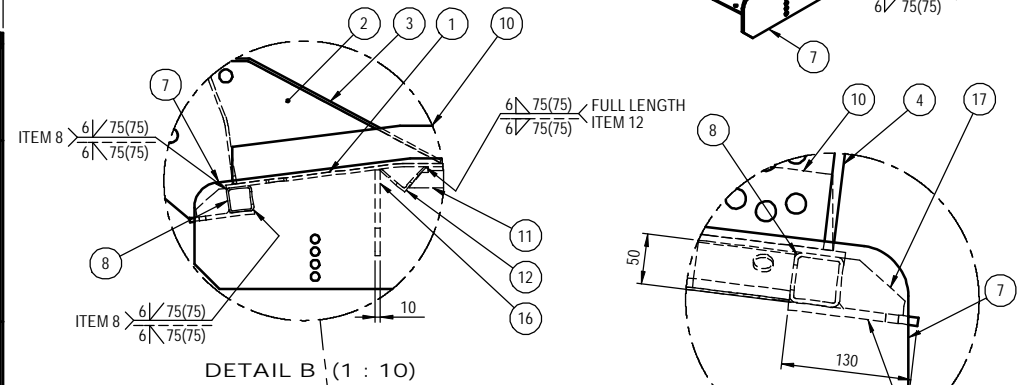

DETAIL B (1 : 10)

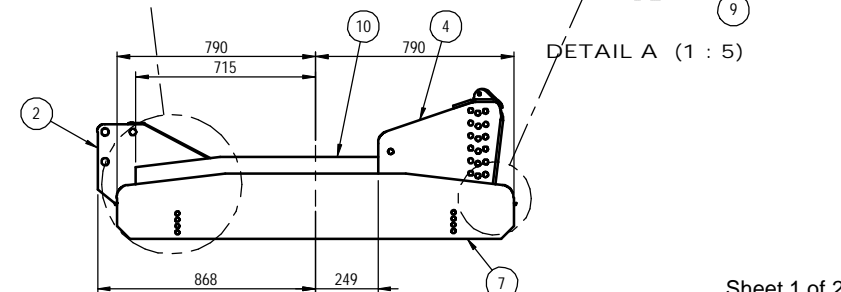

DETAIL A (1 : 5)

Sheet 1 of 2

No.	Description	DWN	CHK	APPD	DATE
P1	PRELIMINARY DRAWING	-	-	-	-
A	APPROVED FOR CONSTRUCTION	-	-	-	-
B	RE-DRAWN WITH MODIFICATIONS	AWP	WP	WP	29.12.16



 Australian owned family business

THIS DRAWING IS PRIVATE AND CONFIDENTIAL AND REMAINS THE PROPERTY OF FIELDQUIP. RETURNED UPON REQUEST. IT MUST NOT BE COPIED OR LOANED WITHOUT THE CONSENT OF FIELDQUIP.

SCALE	1:20	U.N.O
Design	D.M.	-
Drawn	MG	04.06.15
Check	AWP	04.06.15
Appd.	D.M.	04.06.15

GM 360 DECK FABRICATION
GEARMOWER 360 SERIES

3rd ANGLE PROJECTION U.N.O.		A3
Fieldquip Drawing Number		REV
GM36 - 500		B

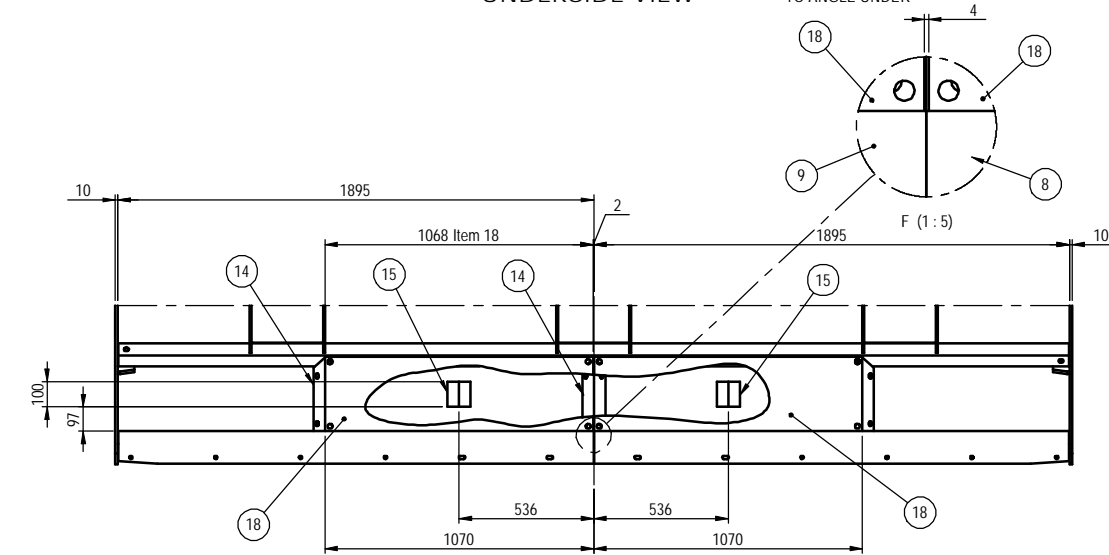
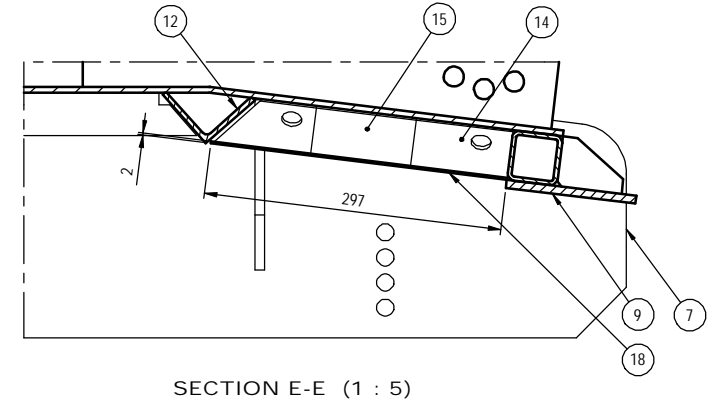
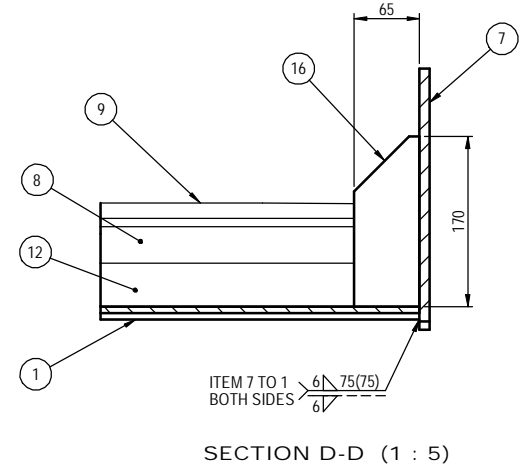
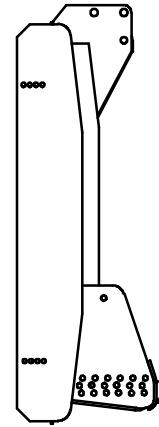
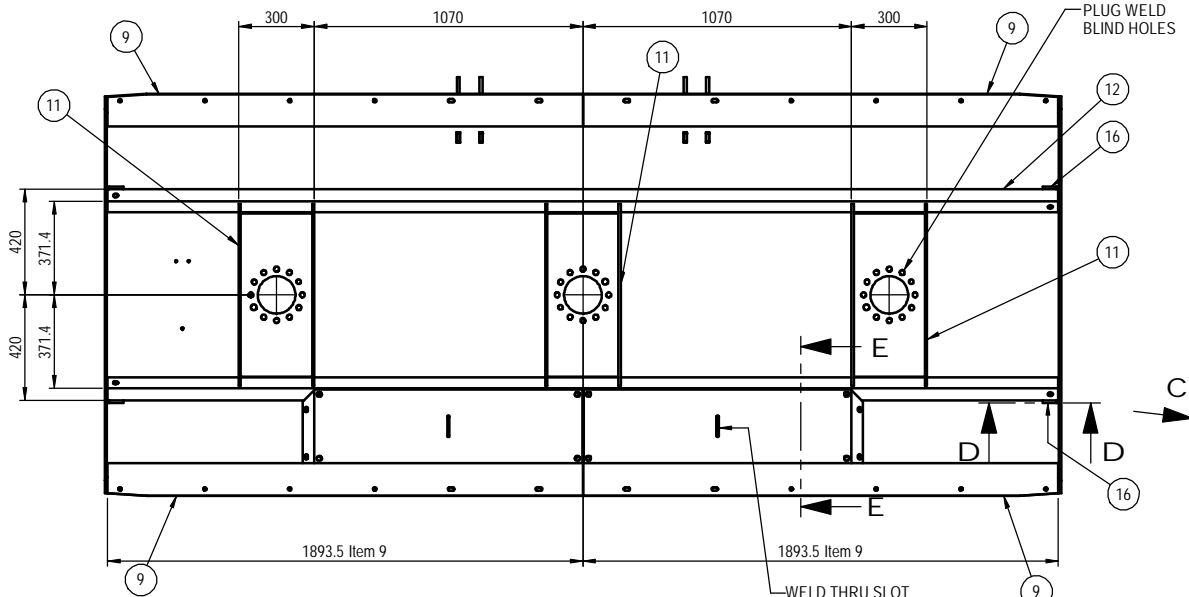

DO NOT SCALE
IF IN DOUBT - ASK WEIGHT 632116.1 GMS

C

199 Bridge Street, Oakley, Qld, 4401



FIELDQUIP
AussieBar owned family business



SCALE	1:20	U.N.O
Design	D.M.	-
Drawn	MG	04.06.15
Check	AWP	04.06.15
Appd.	D.M.	04.06.15

GM 360 DECK FABRICATION

GEARMOWER 360 SERIES

3rd ANGLE PROJECTION U.N.O. A3

Fieldquip Drawing Number REV

GM36 - 500 B

Sheet 2 of 2

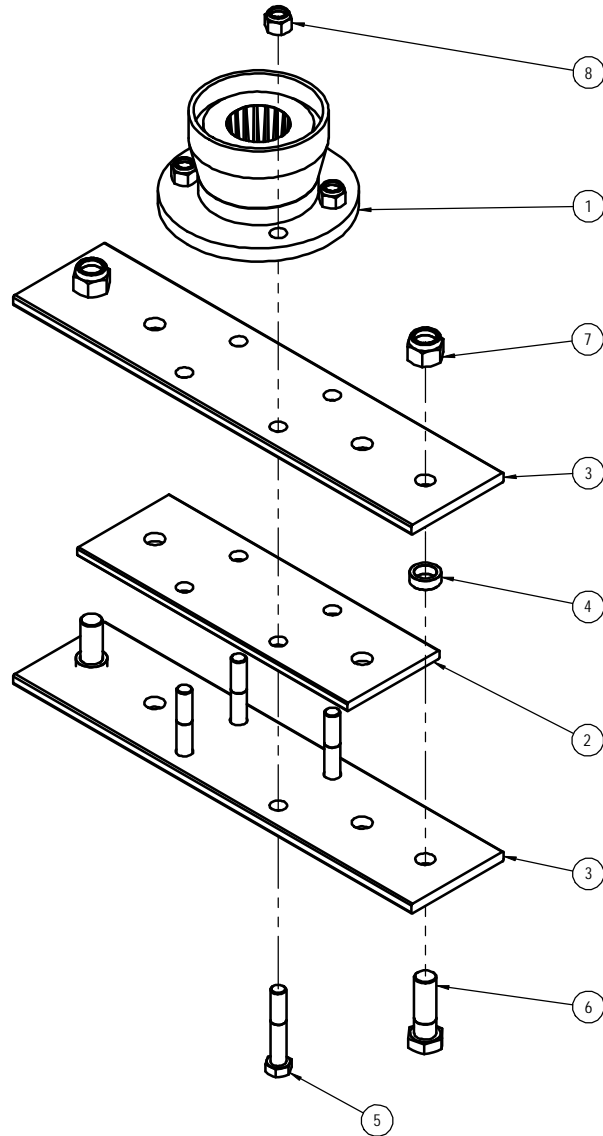

ITEM NO.	QTY.	PART No	DESCRIPTION	DRAWING No	WEIGHT kg	VENDOR	VENDOR No
1	1	XTR100	BLADE HUB ASSY - 200HP	XTR - 100	9.29		
2	1	SBH428	BEAM 130x10x380	Purchased	3.77	PRATCO	SBH 428
3	2	SBH427	BEAM 130x12x560	Purchased	6.67	PRATCO	SBH 427
4	2	BSH322211	BLADE BUSH	BSH-322211	0.03		
5	4	HHB5_8UNF-18T3½	5/8UNF x 4.5" HEX BOLT	Purchased	0.18	MAPTCO	TBA
6	2	HHB7_8UNF-14T2¾	7/8" UNF x 2¾" HEX BOLT	Purchased	0.31	MAPTCO	TBA
7	2	HNN7_8UNF	7/8" UNF HEX NYLOC NUT	Purchased	0.11	MAPTCO	TBA
8	4	HNN5_8UNF	5/8" UNF HEX NYLOC NUT	Purchased	0.04	MAPTCO	TBA

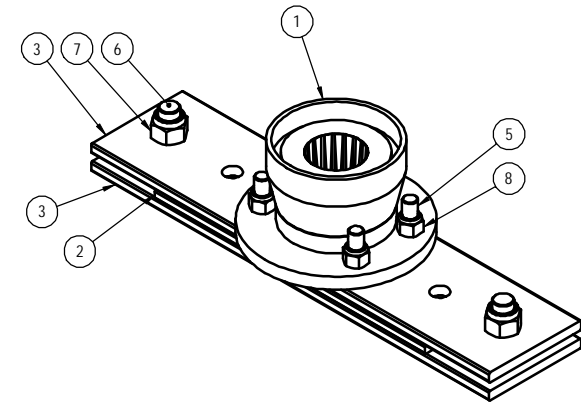

ISOMETRIC VIEW

DO NOT SCALE
IF IN DOUBT - ASK WEIGHT 28184.7 GMS

199 Bridge Street, Oakey, Qld, 4401

Sheet 1 of 1

No.	Description	DWN	CHK	APPD	DATE
P1	PRELIMINARY DRAWING	-	-	-	-
A	APPROVED FOR CONSTRUCTION	-	-	-	-
B	GENERAL TIDY UP	AWP	WP	WP	29.12.16

FIELDQUIP

THIS DRAWING IS PRIVATE AND CONFIDENTIAL AND REMAINS THE PROPERTY OF FIELDQUIP.
 RETURNED UPON REQUEST. IT MUST NOT BE COPIED OR LOANED WITHOUT THE CONSENT OF FIELDQUIP.

SCALE	1:5	U.N.O
Design	D.M.	-
Drawn	MG	13.05.15
Check	AWP	13.05.15
Appd.	D.M.	13.05.15

470mm GM BLADE CARRIER ASSY

GEARMOWER 360 SERIES

3rd ANGLE PROJECTION U.N.O.	A3
Fieldquip Drawing Number	REV
GM36 - 901	B

ITEM NO.	QTY.	PART NUMBER	DRAWING NUMBER	WEIGHT IN kg	DESCRIPTION
1	1	06170-5_9	06170-5	20.1	SKID BODY
2	2	06170-5_8	06170-5	10.0	SKID PLATE
3	2	06170-5_10	06170-5	0.5	SKID ADJUSTER PLATE

NOTE: ALL WELDS 5 CFW UNO

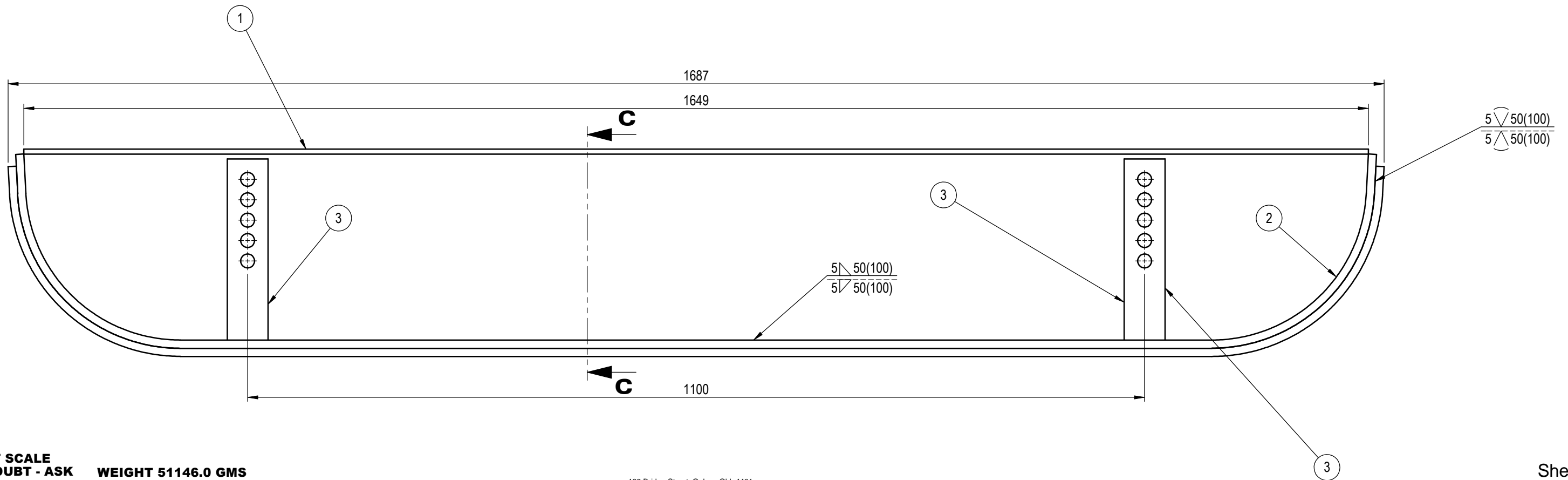
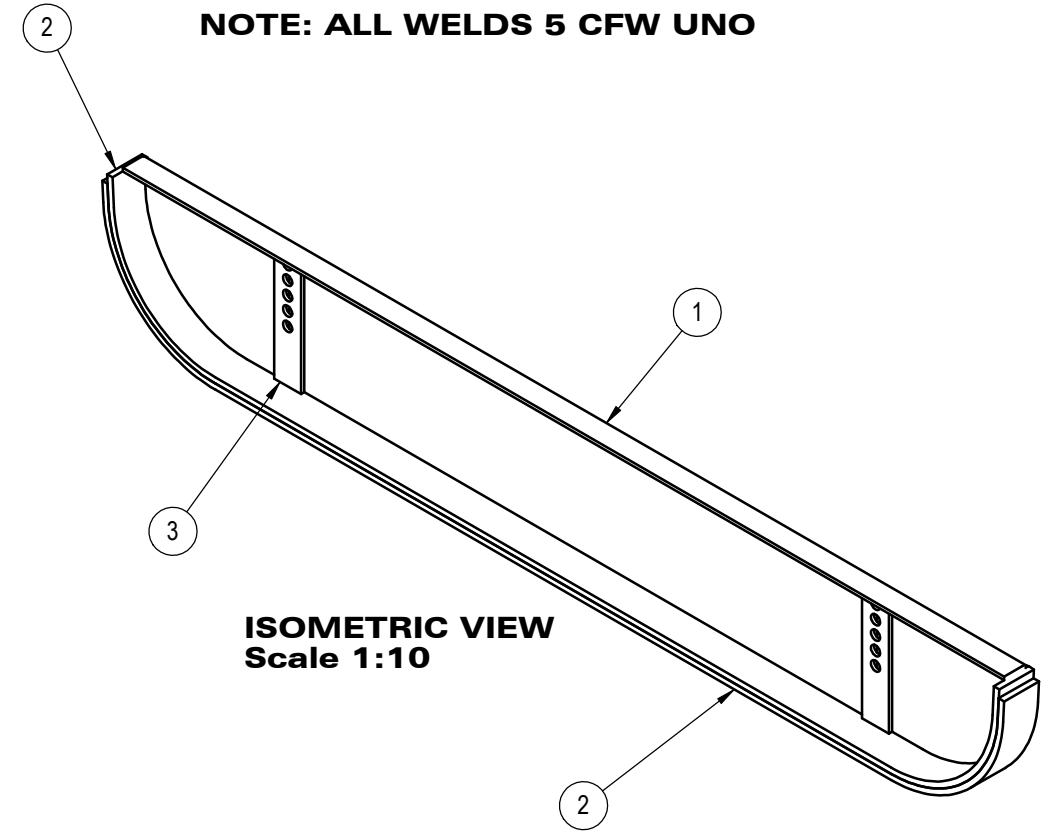
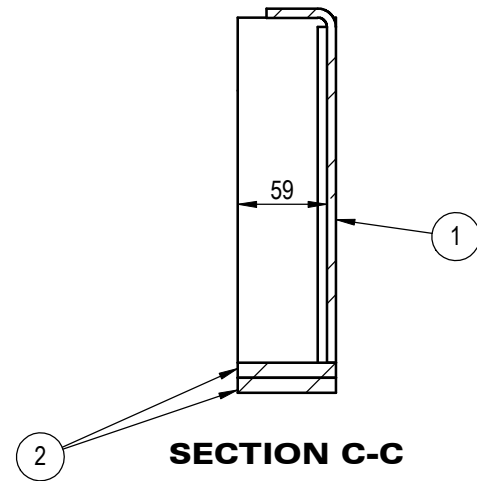

DO NOT SCALE
IF IN DOUBT - ASK **WEIGHT 51146.0 GMS**

Sheet 1 of 1

No.	Description	DWN	CHK	APPD	DATE
P1	PRELIMINARY DRAWING	-	-	-	-
A	APPROVED FOR CONSTRUCTION	-	-	-	-

199 Bridge Street, Oakey, Qld. 4401

FIELDQUIP
Australian owned family business

... smarter gear
... smarter care

THIS DRAWING IS PRIVATE AND CONFIDENTIAL AND REMAINS THE PROPERTY OF FIELDQUIP. RETURNED UPON REQUEST. IT MUST NOT BE COPIED OR LOANED WITHOUT THE CONSENT OF FIELDQUIP.

SCALE	1:5	U.N.O
Design	D.M.	
Drawn	MG	06.05.15
Check	AWP	06.05.15
Appd.	D.M.	06.05.15

L60 SIDE SKID ASSY

LS SLASHER

3rd ANGLE PROJECTION U.N.O.		A3
Fieldquip Drawing Number		REV
06165-5		A

ITEM NO.	QTY.	PART No	DESCRIPTION	DRAWING No	WEIGHT kg	VENDOR	VENDOR No
1	1	HSM020	XTREME HEADSTOCK ARM RH	HSM - 20	12.13		
2	1	HSM021	XTREME HEADSTOCK ARM LH	HSM - 21	12.13		
3	2	HSM012	HEADSTOCK SPACER	HSM - 12	0.08		
4	1	HSM019	HEADSTOCK SPACER - SHORT	HSM - 19	0.06		
5	2	WF11N	1" FLAT WASHER	Purchased	0.04	TBA	TBA
6	3	LPB81	HEADSTOCK PIVOT PIN	Purchased	0.60	Bare Co	B81
7	3	LP10D	10mm LYNCH PIN	Purchased	0.05	Bare Co	B6
8	3	HHB5_8UNF-18T4½	5/8UNF x 4½" HEX BOLT	Purchased	0.22	MAPTCO	TBA
9	3	WF16M	M16 FLAT WASHER	Purchased	0.01	TBA	TBA
10	3	HNN5_8UNF	5/8" UNF HEX NYLOC NUT	Purchased	0.04	MAPTCO	TBA
11	2	HSM013	CHAIN BRACKET	HSM - 13	0.82		
12	2	DSHC13	13mm D-Shackle	Purchased	0.23	TBA	TBA

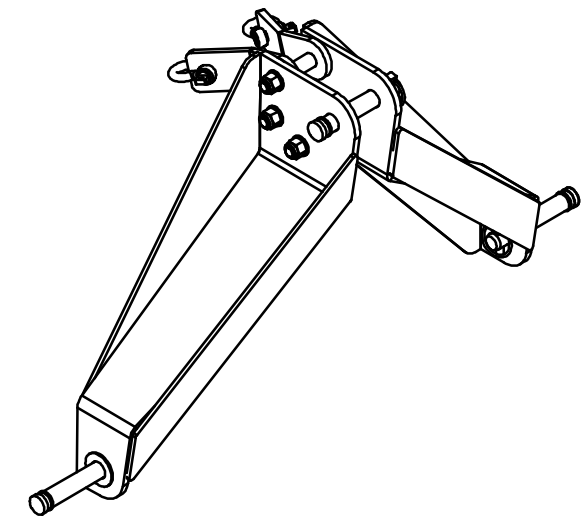
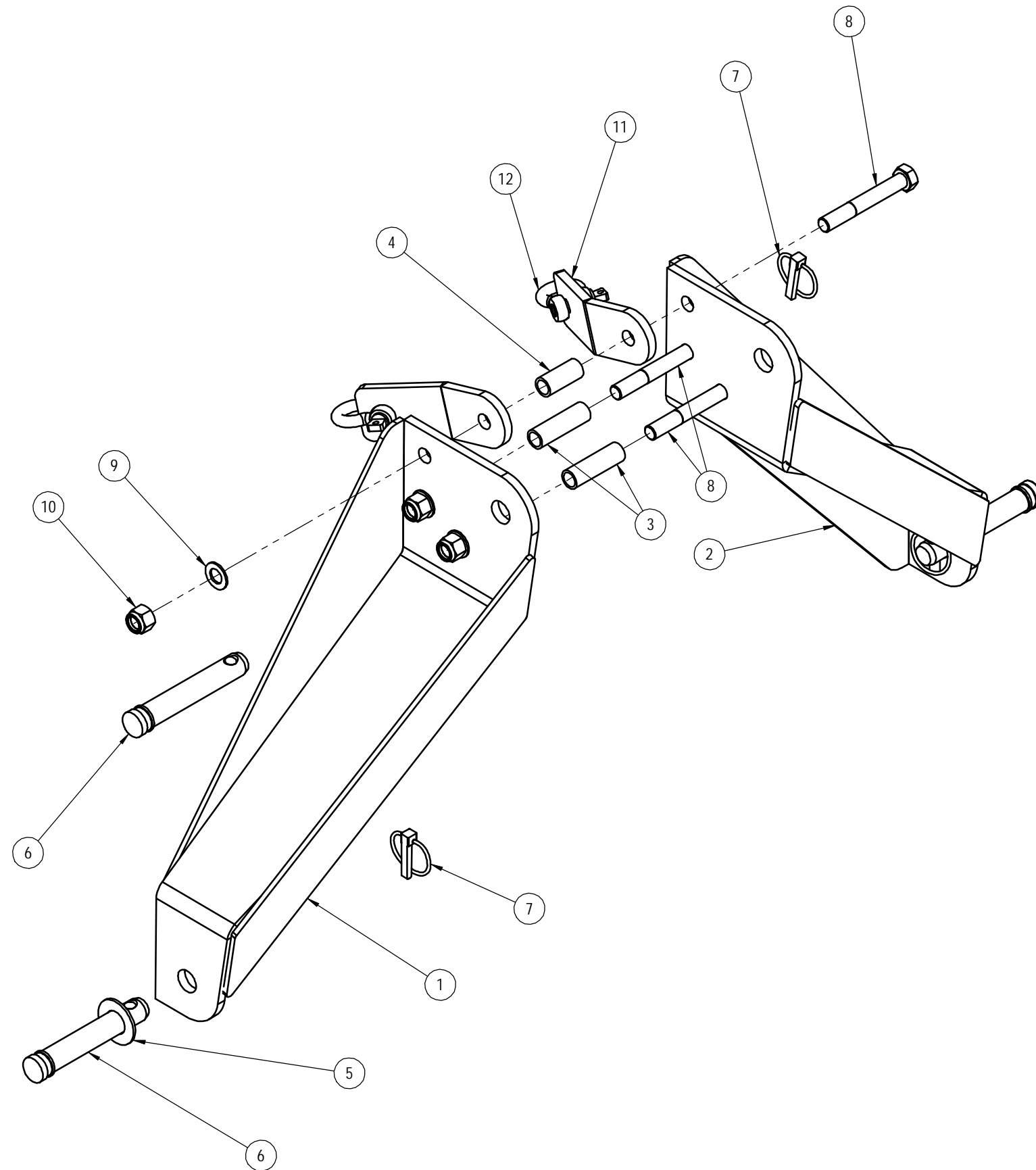

ISOMETRIC VIEW
SCALE 1:10

DO NOT SCALE
IF IN DOUBT - ASK WEIGHT 29385.0 GMS

Sheet 1 of 1

No.	Description	DWN	CHK	APPD	DATE
P1	PRELIMINARY DRAWING	-	-	-	-
A	APPROVED FOR CONSTRUCTION	-	-	-	-

199 Bridge Street, Oakey, Qld, 4401



FIELDQUIP

...smarter gear
...smarter care
Australian owned family business

THIS DRAWING IS PRIVATE AND CONFIDENTIAL AND REMAINS THE PROPERTY OF FIELDQUIP.
RETURNED UPON REQUEST. IT MUST NOT BE COPIED OR LOANED WITHOUT THE CONSENT OF FIELDQUIP.

SCALE	1:5	U.N.O
Design	D.M.	-
Drawn	MG	13.05.15
Check	AWP	13.05.15
Appd.	D.M.	13.05.15

GEARMOWER HEADSTOCK	
GEARMOWER COMMON PARTS	

3rd ANGLE PROJECTION U.N.O.	A3
Fieldquip Drawing Number	REV
GMC - 904	A

ITEM NO.	QTY.	PART No	DESCRIPTION	DRAWING No	WEIGHT kg	VENDOR	VENDOR No
1	1	GMC-500	CASTOR ARM	GMC - 500	16.67		
2	1	CSTW380	Ø380 CASTOR WHEEL	Purchased	41.05	TBA	TBA
3	3	LPB77	PIVOT PIN	Purchased	0.35	Bare Co	B 77
4	3	LP10D	10mm LYNCH PIN	Purchased	0.05	Bare Co	B6

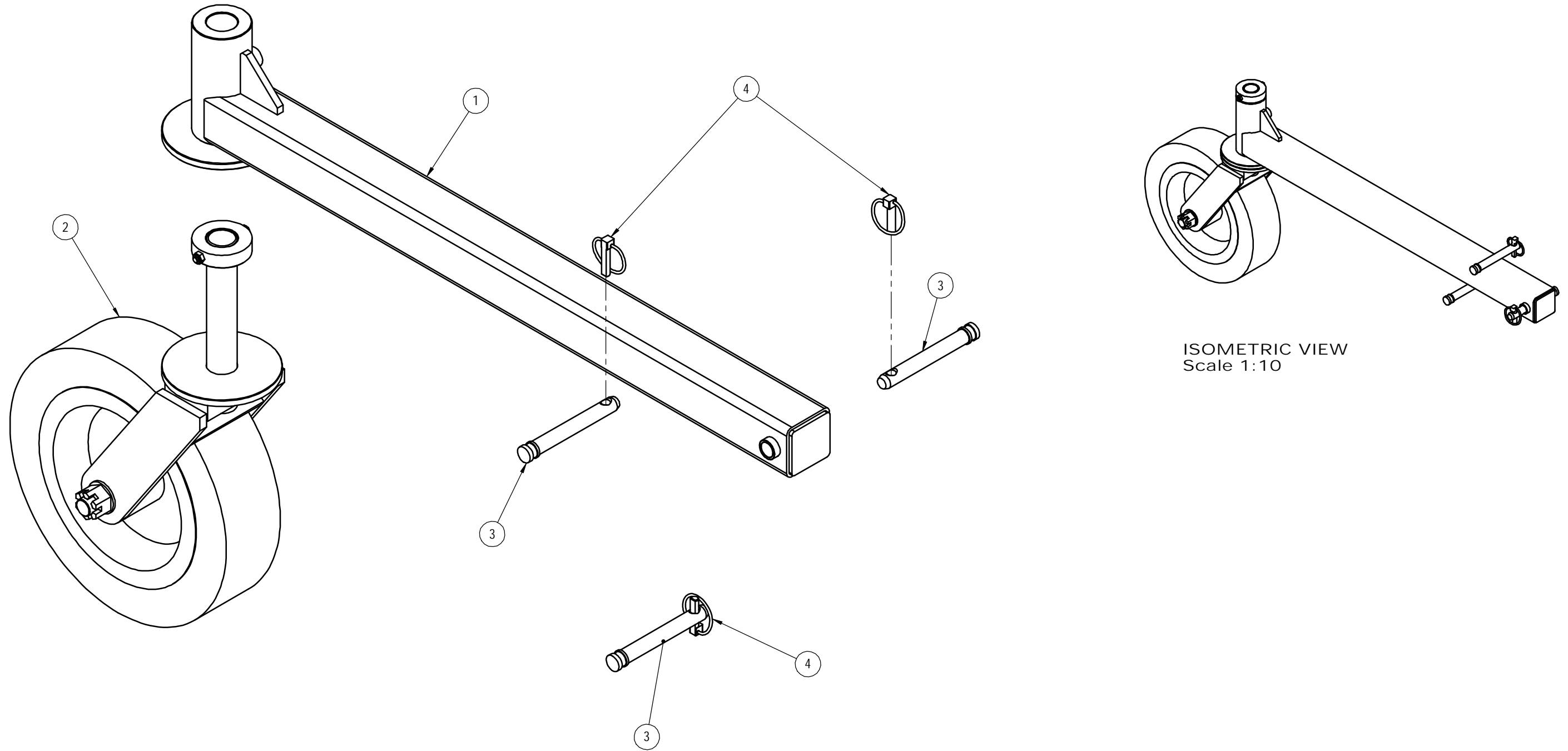

DO NOT SCALE
IF IN DOUBT - ASK WEIGHT 58893.8 GMS

Sheet 1 of 1

No.	Description	DWN	CHK	APPD	DATE
P1	PRELIMINARY DRAWING	-	-	-	-
A	APPROVED FOR CONSTRUCTION	-	-	-	-

199 Bridge Street, Oakey, Qld, 4401



FIELDQUIP

...smarter gear
...smarter care
Australian owned family business

THIS DRAWING IS PRIVATE AND CONFIDENTIAL AND REMAINS THE PROPERTY OF FIELDQUIP.
RETURNED UPON REQUEST. IT MUST NOT BE COPIED OR LOANED WITHOUT THE CONSENT OF FIELDQUIP.

SCALE	1:5	U.N.O
Design	D.M.	-
Drawn	MG	12.12.16
Check	AWP	15.12.16
Appd.	D.M.	15.12.16

GEARMOWER WHEEL & ARM	
GEARMOWER COMMON PARTS	

3rd ANGLE PROJECTION U.N.O.	A3
Fieldquip Drawing Number	REV
GMC - 905	A