

ITEM NO.	QTY.	PART No	DESCRIPTION	DRAWING No	WEIGHT kg	VENDOR	VENDOR No
1	1	GM30-500	GEARMOWER 300 DECK FAB.	GM30 - 500	509.95		
2	1	GMC-904	GEARMOWER HEADSTOCK	GMC - 904	29.39		
3	2	LPB216	HEAVY DUTY PIN - 105	Purchased	0.70	Bare Co	B216
4	2	LP10D	10mm LYNCH PIN	Purchased	0.05	Bare Co	B6
5	2	GMC-905	GEARMOWER WHEEL & ARM	GMC - 905	58.89		
6	18	HHB3/4UNF-16T3	3/4" UNF x 3" HEX BOLT	Purchased	0.23	MAPTCO	TBA
7	18	HNN3/4UNF	3/4" UNF HEX NYLOC NUT	Purchased	0.06	MAPTCO	TBA
8	18	WF20MHT	M20 HIGH TENSILE FLAT WASHER	Purchased	0.02	TBA	TBA
9	4	GMC-002	CHAIN GUARD	GMC - 02	9.74		
10	2	GM30-012	CHAIN GUARD MID	GM30 - 12	7.16		
11	20	HHB40M12	M12 x 40 HEX HEAD BOLT	Purchased	0.05	TBA	TBA
12	20	HNN12M	M12 NYLOC NUT	Purchased	0.02	TBA	TBA
13	20	WF12M	M12 FLAT WASHER	Purchased	0.01	TBA	TBA
14	2	DSHC13	13mm D-Shackle	Purchased	0.23	TBA	TBA
15	2	GMC-005	HEADSTOCK CHAIN	GMC - 05	4.66		
16	2	GMC-501	SKID - 850	GMC - 501	35.58		
17	8	HHB50M16	M16 x 50 HEX BOLT	Purchased	0.12	TBA	TBA
18	8	HNN16M	M16 HEX HEAD NUT	Purchased	0.04	TBA	TBA
19	8	WF16M	M16 FLAT WASHER	Purchased	0.01	TBA	TBA
20	8	SW16	M16 SP WASHER ZN PL	Purchased	0.00	TBA	TBA
21	118	LS80_23	CHAIN - GUARD	LS80 - 23	0.44		
22	2	GM30-017	CHAIN RETAINER ROPE	GM30 - 17	0.76		
23	3	GMC-900	306mm GM BLADE CARRIER ASSY	GMC - 900	22.24		
24	4	DRV050	HEAVY DUTY COVER MOUNT	DRV - 50	1.52		
25	2	GM30-016	GM 300 G.BOX CONNECT COVER	GM30 - 16	6.53		
26	16	HHB25M10	M10 x 40 HEX HEAD BOLT	Purchased	0.03	TBA	TBA
27	16	SW10	M10 SPRING WASHER ZN PL	Purchased	0.00	TBA	TBA
28	16	WF10M	M10 FLAT WASHER	Purchased	0.00	TBA	TBA
29	20	HHB5_16UNC-18T3/4	5/16UNC x 3/4 HEX BOLT	Purchased	0.01	MAPTCO	TBA
30	4	1060L	LH SLASHER BLADE 408mm	Purchased	2.80	PRATCO	SBH 415
31	2	1060R	RH SLASHER BLADE 408mm	Purchased	2.80	PRATCO	SBH 416
32	1	GM30-600	GEARBOX DRIVE ASSEMBLY	GM30 - 600	405.38		
33	4	UCLP8mm	8mm U-CLAMP	Purchased	0.08	TBA	TBA
34	11	HNN8M	M8 NYLOC NUT	Purchased	0.01	TBA	TBA
35	1	ENC001	DOCUMENT HOLDER	Purchased	0.64	Bare Co	B1970
36	3	HHB25M8	M8 x 25 HEX BOLT	Purchased	0.02	TBA	TBA
37	3	WF8M	M8 FLAT WASHER	Purchased	0.00	TBA	TBA

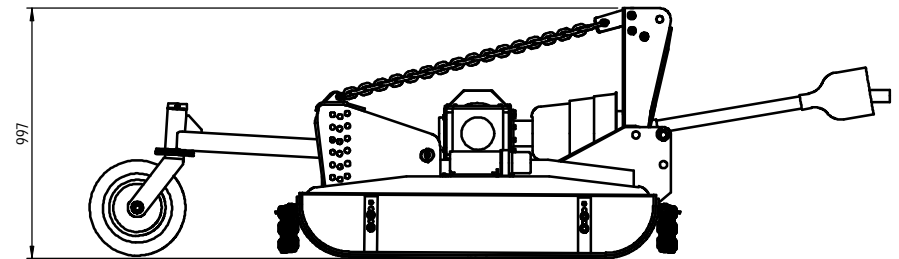
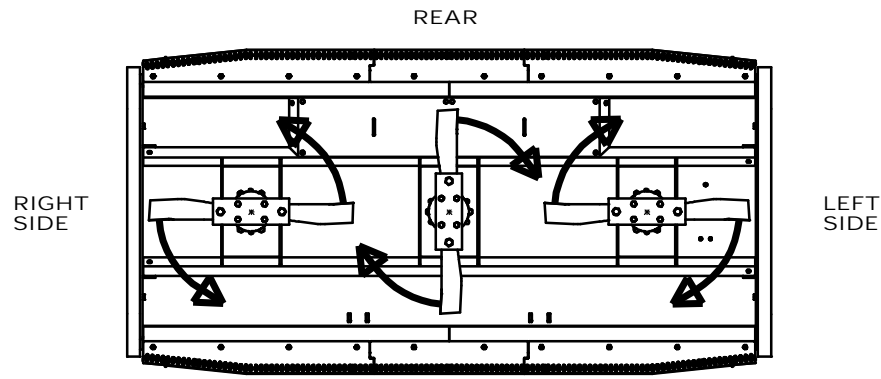
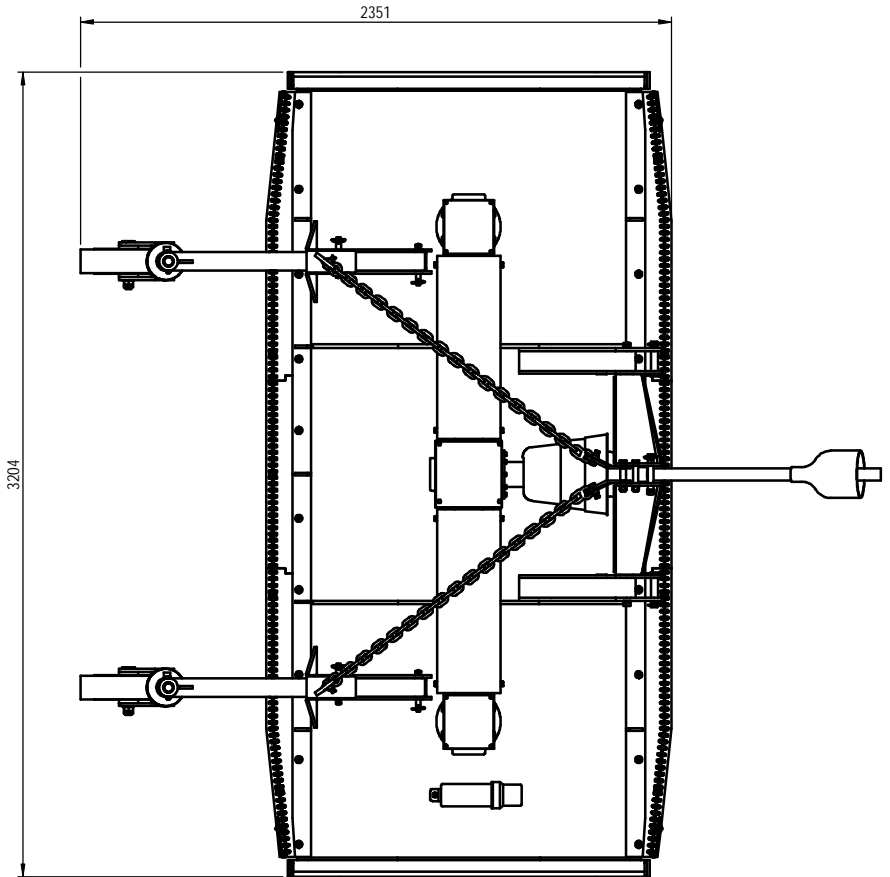

DO NOT SCALE  
IF IN DOUBT - ASK WEIGHT 1364672.3 GMS

FRONT

No.	Description	DWN	CHK	APPD	DATE
P1	PRELIMINARY DRAWING	-	-	-	-
A	APPROVED FOR CONSTRUCTION	-	-	-	-
B	GENERAL REVISION AND TIDY UP	AWP	WP	WP	25.12.16

199 Bridge Street, Oakley, Qld, 4401

THIS DRAWING IS PRIVATE AND CONFIDENTIAL AND REMAINS THE PROPERTY OF FIELDQUIP. RETURNED UPON REQUEST. IT MUST NOT BE COPIED OR LOANED WITHOUT THE CONSENT OF FIELDQUIP.

SCALE	1:20	U.N.O
Design	D.M.	-
Drawn	MG	01.05.15
Check	AWP	01.05.15
Appd.	D.M.	01.05.15

150HP GEARMOWER 300 ASSY

150HP GEARMOWER 300 SERIES

3rd ANGLE PROJECTION U.N.O.		A3
Fieldquip	Drawing Number	REV
GM30 - 900		B

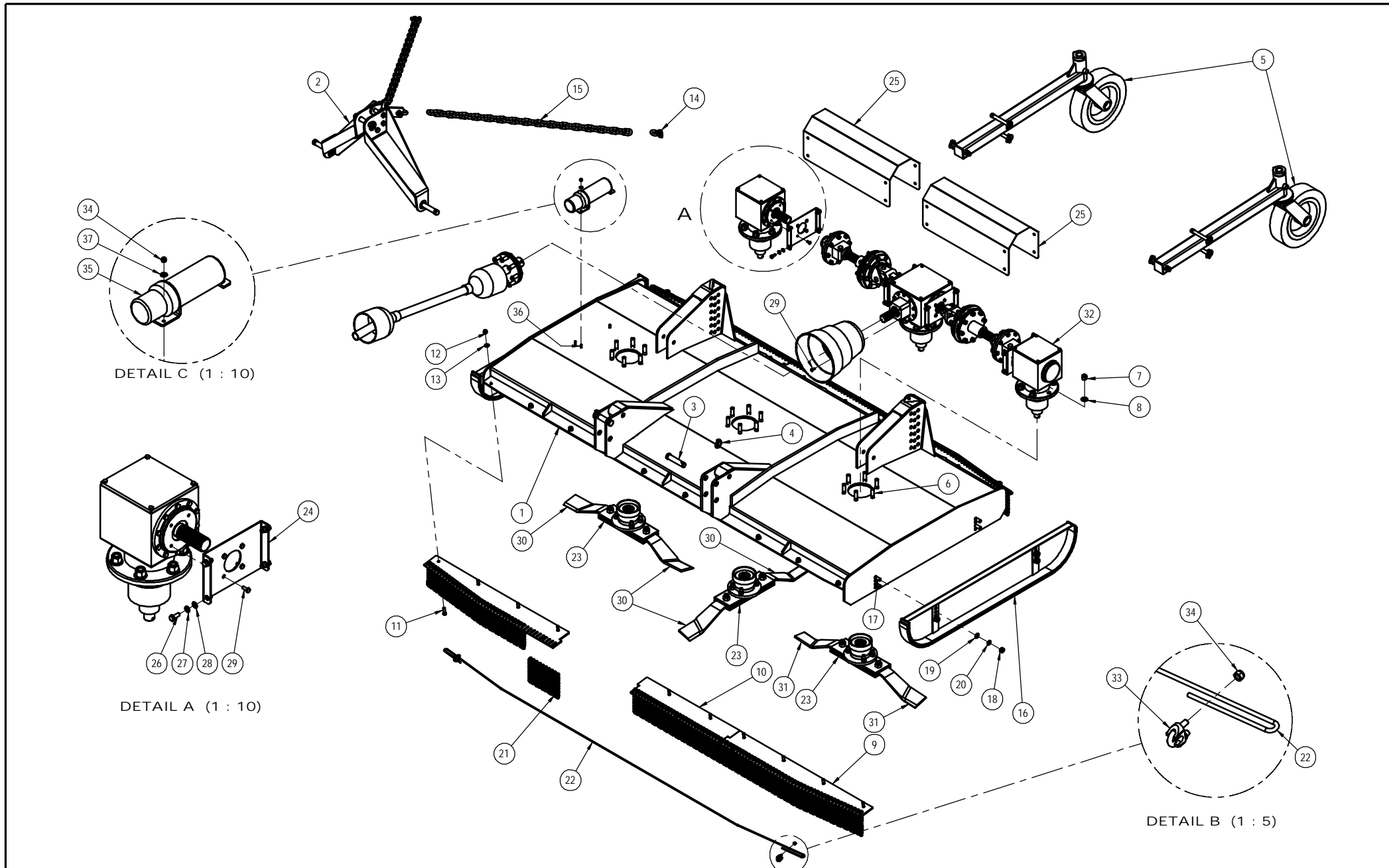

DETAIL C (1 : 10)

DETAIL A (1 : 10)

DETAIL B (1 : 5)

DO NOT SCALE  
IF IN DOUBT - ASK WEIGHT 1364672.3 GMS

199 Bridge Street, Oakley, Qld, 4401

Sheet 2 of 2

No.	Description	DWN	CHK	APPD	DATE
P1	PRELIMINARY DRAWING	-	-	-	-
A	APPROVED FOR CONSTRUCTION	-	-	-	-
B	GENERAL REVISION AND TIDY UP	AWP	WP	WP	25.12.16

THIS DRAWING IS PRIVATE AND CONFIDENTIAL AND REMAINS THE PROPERTY OF FIELDQUIP. RETURNED UPON REQUEST. IT MUST NOT BE COPIED OR LOANED WITHOUT THE CONSENT OF FIELDQUIP.

SCALE	1:20	U.N.O
Design	D.M.	-
Drawn	MG	01.05.15
Check	AWP	01.05.15
Appd.	D.M.	01.05.15

150HP GEARMOWER 300 ASSY  
150HP GEARMOWER 300 SERIES

3rd ANGLE PROJECTION U.N.O.	A3
Fieldquip Drawing Number	REV
GM30 - 900	B

ITEM NO.	QTY	PART No	DESCRIPTION	DRAWING No	WEIGHT kg	VENDOR	VENDOR No
1	1	GC - 30-33	DRIVE KIT (Bare Co - AN 303 C)	GC - 30-33	398.83	Bare Co	AN 303 C
2	2	GM30-002	INTERCONNECTING SHAFT	GM30 - 02	3.27		

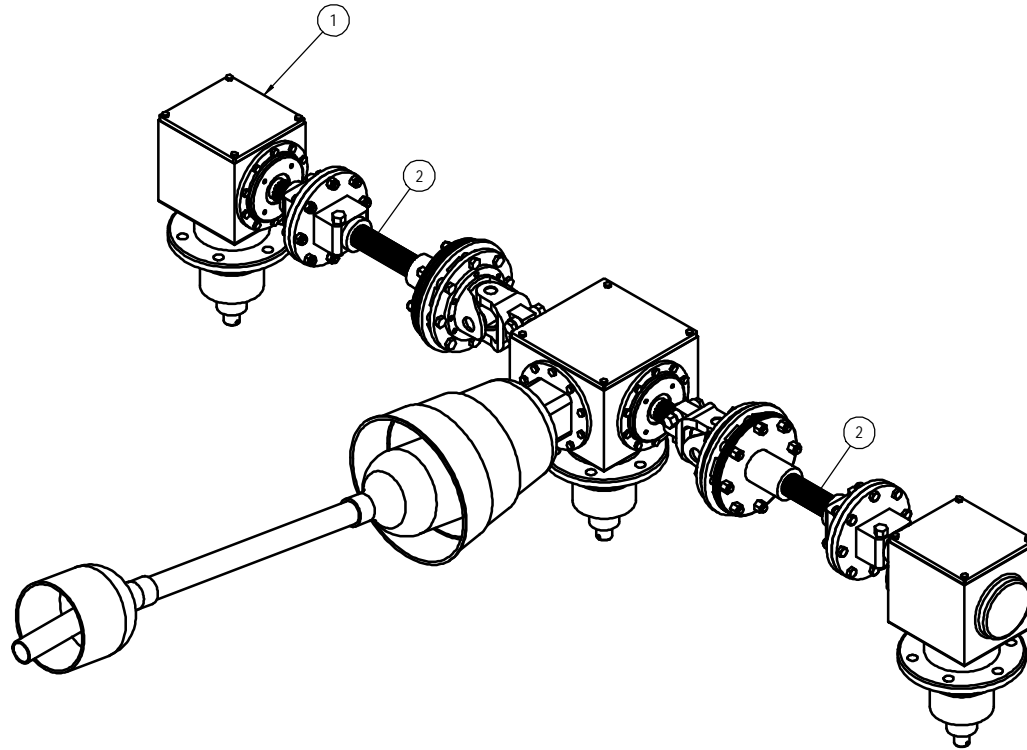

DO NOT SCALE  
IF IN DOUBT - ASK      WEIGHT 405378.3 GMS

199 Bridge Street, Oakay, Qld, 4401

Sheet 1 of 1

No.	Description	DWN	CHK	APPD	DATE
P1	PRELIMINARY DRAWING	-	-	-	-
A	APPROVED FOR CONSTRUCTION	-	-	-	-

**FIELDQUIP**  
Australian owned family business

THIS DRAWING IS PRIVATE AND CONFIDENTIAL AND REMAINS THE PROPERTY OF FIELDQUIP.  
RETURNED UPON REQUEST. IT MUST NOT BE COPIED OR LOANED WITHOUT THE CONSENT OF FIELDQUIP.

SCALE	1:10	U.N.O
Design	D.M.	-
Drawn	AWP	25.12.16
Check	WP	09.01.17
Appd.	WP	09.01.17

**GEARBOX DRIVE ASSEMBLY**

**GEARMOWER 300 SERIES**

3rd ANGLE PROJECTION U.N.O.		A3
Fieldquip	Drawing Number	REV
GM30 - 600		A

ITEM NO.	QTY.	PART NUMBER	DRAWING NUMBER	WEIGHT IN kg	DESCRIPTION
1	1	GM30-001	GM30 - 01	193.2	GM300 CUTTER DECK
2	4	GMC-023	GMC - 23	9.1	OUTER LIFT PLATE
3	2	HSM015	HSM - 15	2.8	LIFT PLATE GUSSET
4	2	GMC-022	GMC - 22	10.6	CASTOR WHEEL BRACKET - LH
5	2	GMC-021	GMC - 21	10.6	CASTOR WHEEL BRACKET - RH
6	2	GMC-012	GMC - 12	1.4	CHAIN MOUNT PLATE
7	2	GMC-013	GMC - 13	26.2	DECK SIDE STIFFENER PLATE
8	2	GM30-005	GM30 - 05	16.8	CHAIN GUARD SUPPORT
9	4	GM30-006	GM30 - 06	12.4	CHAIN GUARD MOUNT PLATE
10	2	GMC-011	GMC - 11	11.1	DECK STIFFENER
11	3	GMC-001	GMC - 01	9.1	DECK GEARBOX STIFFENER
12	2	GM30-008	GM30 - 08	14.0	UNDER DECK SUPPORT
13	2	GMC-010	GMC - 10	0.3	CHAIN ANCHOR POINT
14	3	GMC-017	GMC - 17	1.2	UNDER DECK SPACER
15	1	GMC-008	GMC - 08	7.0	GRASS DEFLECTOR
16	2	GMC-018	GMC - 18	0.5	GRASS PLATE SUPPORT
17	4	GMC-019	GMC - 19	0.8	SKID PLATE GUSSET
18	8	XTR90-006	XTR90 - 06	0.2	GUARD SUPPORT GUSSET - 7°

ALL WELDS 6 CFW UNO

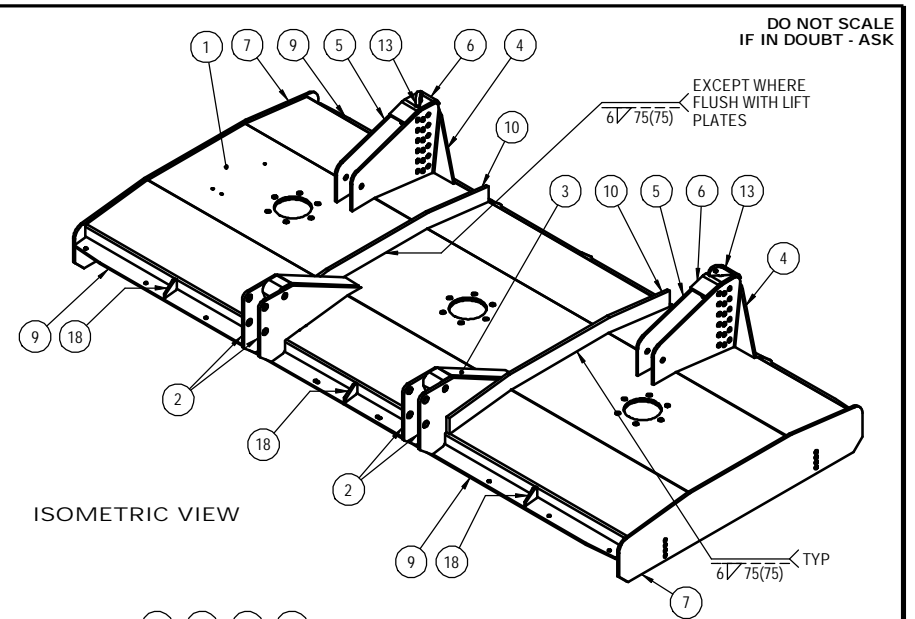
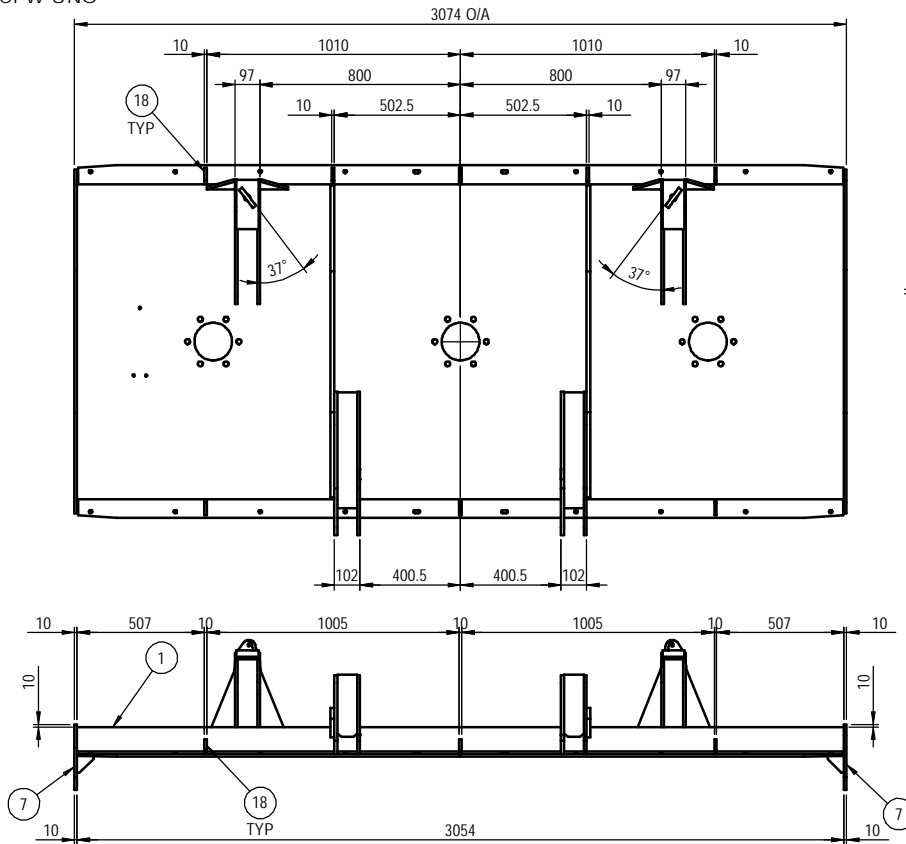

ISOMETRIC VIEW

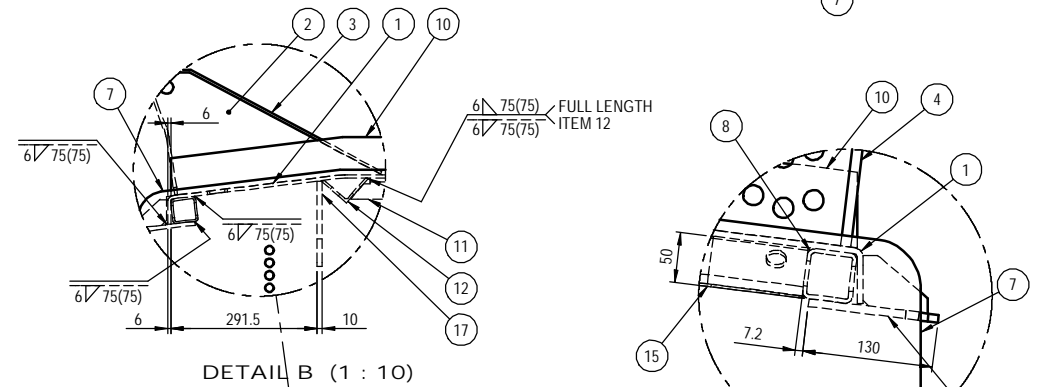

DETAIL B (1 : 10)

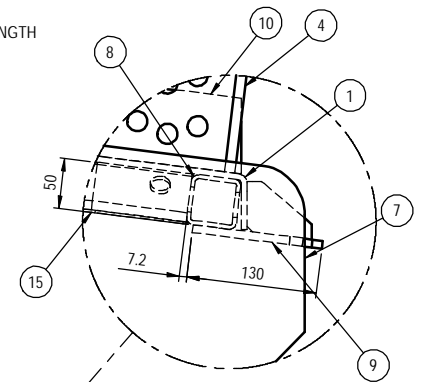

DETAIL A (1 : 5)

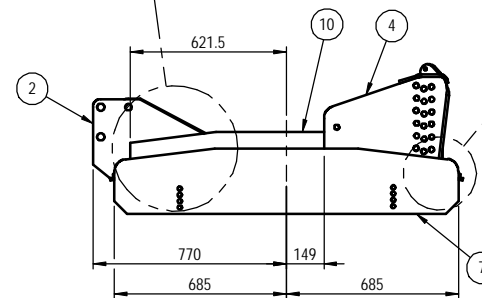

WEIGHT 509950.1 GMS

199 Bridge Street, Oakay, Qld, 4401

No.	Description	DWN	CHK	APPD	DATE
PT	PRELIMINARY DRAWING	-	-	-	-
A	APPROVED FOR CONSTRUCTION	-	-	-	-

**FIELDQUIP**  
Australian owned family business

THIS DRAWING IS PRIVATE AND CONFIDENTIAL AND REMAINS THE PROPERTY OF FIELDQUIP. RETURNED UPON REQUEST. IT MUST NOT BE COPIED OR LOANED WITHOUT THE CONSENT OF FIELDQUIP.

SCALE	1:20	U.N.O
Design	D.M.	-
Drawn	AWP	22.12.16
Check	WP	09.01.17
Appd.	WP	09.01.17

**GEARMOWER 300 DECK FAB.**

**GEARMOWER 300 SERIES**

3rd ANGLE PROJECTION U.N.O.		A3
Fieldquip Drawing Number		REV
GM30 - 500		A

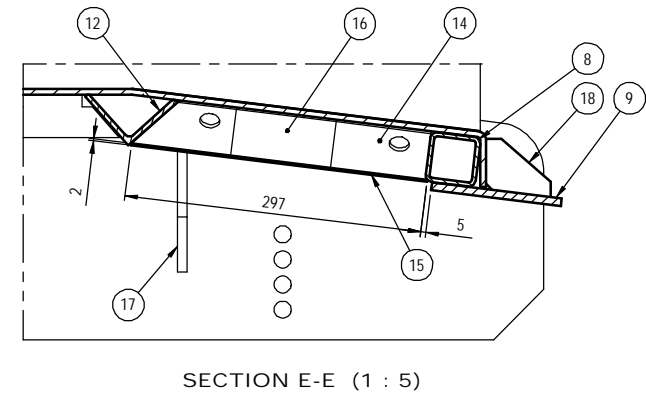
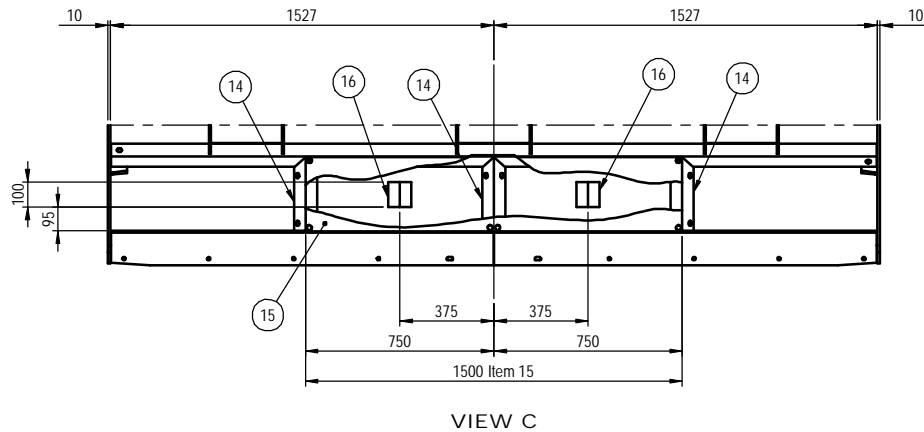
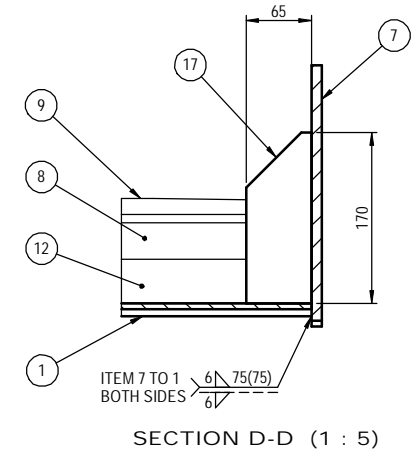
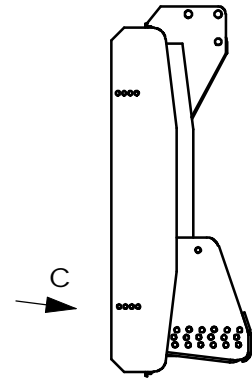
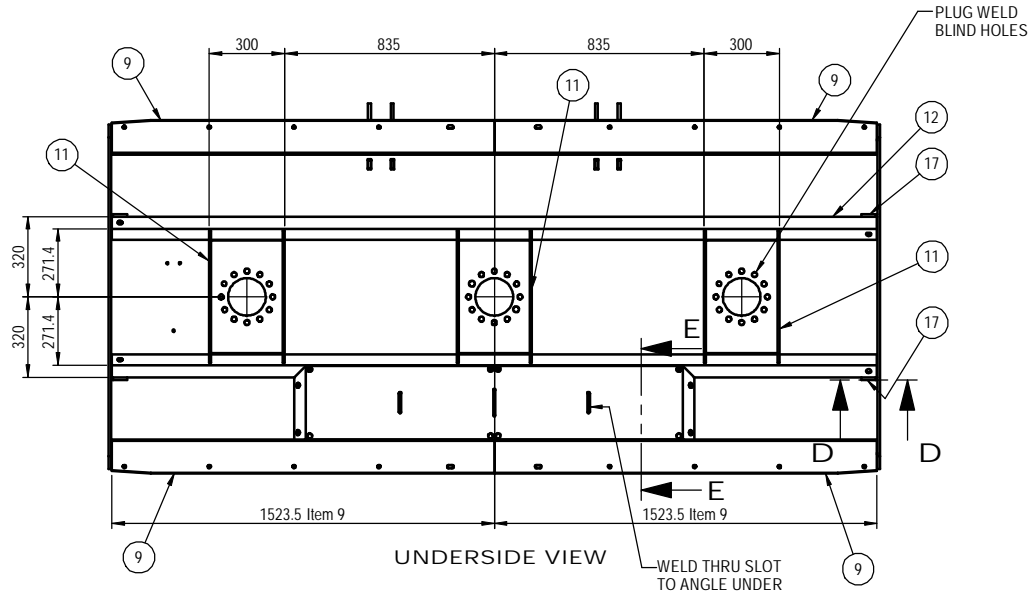

DO NOT SCALE  
IF IN DOUBT - ASK WEIGHT 509950.1 GMS

No.	Description	DWN	CHK	APPD	DATE
P1	PRELIMINARY DRAWING	-	-	-	-
A	APPROVED FOR CONSTRUCTION	-	-	-	-

199 Bridge Street, Oakley, Qld, 4401

**FIELDQUIP**  
Australia's owned family business

THIS DRAWING IS PRIVATE AND CONFIDENTIAL AND REMAINS THE PROPERTY OF FIELDQUIP.  
RETURNED UPON REQUEST. IT MUST NOT BE COPIED OR LOANED WITHOUT THE CONSENT OF FIELDQUIP.

SCALE	1:20	U.N.O
Design	D.M.	-
Drawn	AWP	22.12.16
Check	WP	09.01.17
Appd.	WP	09.01.17

GEARMOWER 300 DECK FAB.  
GEARMOWER 300 SERIES

3rd ANGLE PROJECTION U.N.O.		A3
Fieldquip	Drawing Number	REV
GM30 - 500		A

ITEM NO.	QTY.	PART NUMBER	DRAWING NUMBER	WEIGHT IN kg	DESCRIPTION
1	1	GMC-006	GMC - 06	17.0	SKID BODY
2	2	GMC-007	GMC - 07	8.8	SKID PLATE
3	2	06165-5_11	06165-5 - 11	0.5	SKID ADJUSTER PLATE

NOTE: ALL WELDS 5 CFW UNO

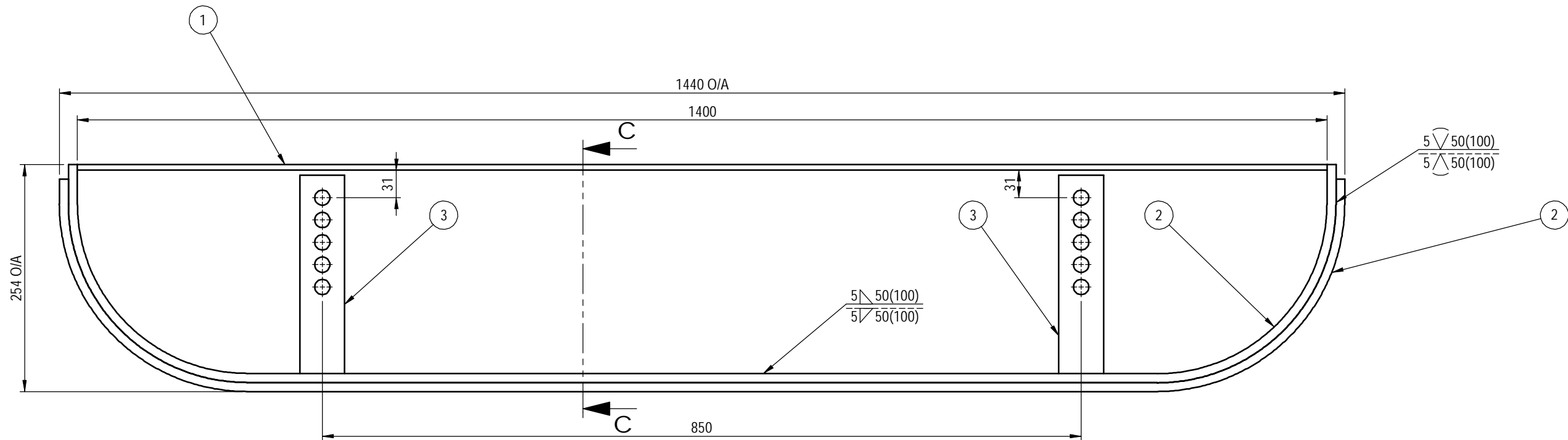
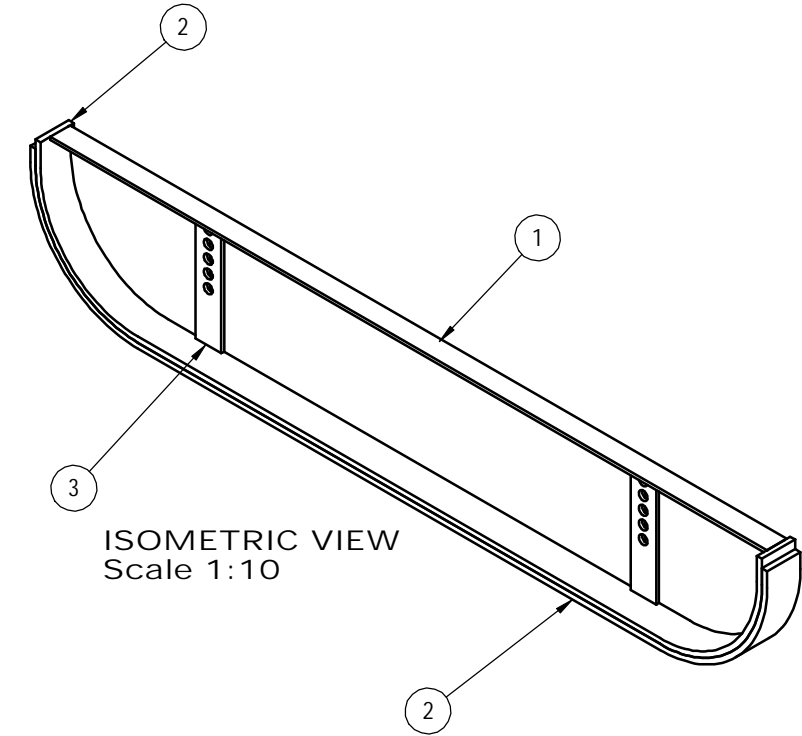
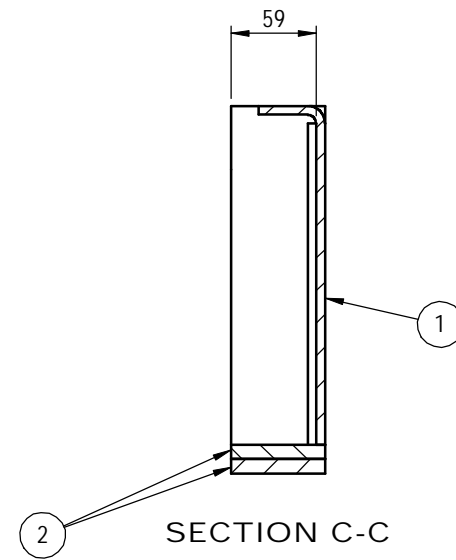

DO NOT SCALE  
IF IN DOUBT - ASK WEIGHT 35576.1 GMS

Sheet 1 of 1

No.	Description	DWN	CHK	APPD	DATE
P1	PRELIMINARY DRAWING	-	-	-	-
A	APPROVED FOR CONSTRUCTION	-	-	-	-

199 Bridge Street, Oakey, Qld, 4401

THIS DRAWING IS PRIVATE AND CONFIDENTIAL AND REMAINS THE PROPERTY OF FIELDQUIP.  
RETURNED UPON REQUEST. IT MUST NOT BE COPIED OR LOANED WITHOUT THE CONSENT OF FIELDQUIP.

SCALE	1:5	U.N.O
Design	D.M.	
Drawn	MG	06.05.15
Check	AWP	06.05.15
Appd.	D.M.	06.05.15

SKID - 850

GEARMOWER COMMON PARTS

3rd ANGLE PROJECTION U.N.O.	A3
Fieldquip Drawing Number	REV
GMC - 501	A

ITEM NO.	QTY.	PART No	DESCRIPTION	DRAWING No	WEIGHT kg	VENDOR	VENDOR No
1	1	XTR100	BLADE HUB ASSY - 200HP	XTR - 100	9.29		
2	1	GMC-418	BLADE BEAM SPACER	GMC - 418	2.15		
3	2	SBH419	BEAM 130x12x380	Purchased	4.50	Pratco	SBH 419
4	2	BSH322211	BLADE BUSH	BSH-322211	0.03		
5	4	HHB5_8UNF-18T3½	5/8UNF x 4.5" HEX BOLT	Purchased	0.18	MAPTCO	TBA
6	2	HHB7_8UNF-14T2¾	7/8" UNF x 2¾" HEX BOLT	Purchased	0.31	MAPTCO	TBA
7	2	HNN7_8UNF	7/8" UNF HEX NYLOC NUT	Purchased	0.11	MAPTCO	TBA
8	4	HNN5_8UNF	5/8" UNF HEX NYLOC NUT	Purchased	0.04	MAPTCO	TBA

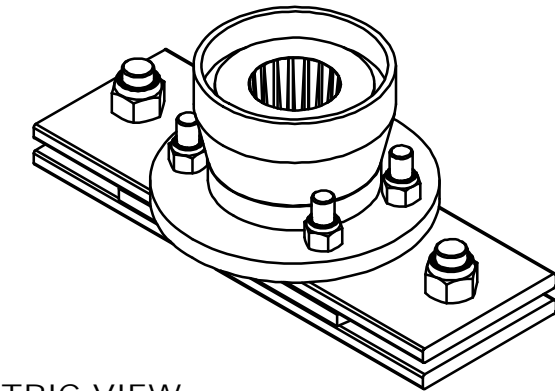
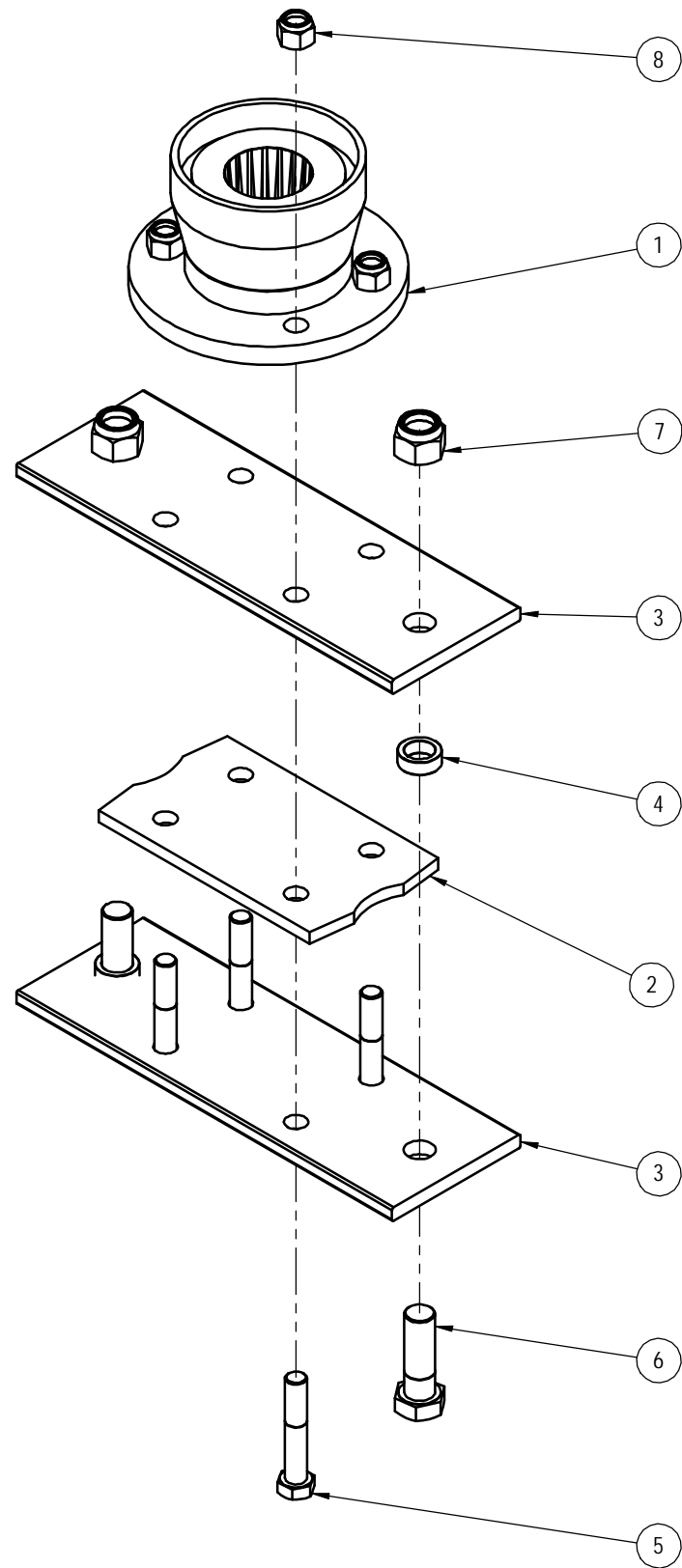

ISOMETRIC VIEW

DO NOT SCALE  
IF IN DOUBT - ASK WEIGHT 22235.1 GMS

Sheet 1 of 1

No.	Description	DWN	CHK	APPD	DATE
P1	PRELIMINARY DRAWING	-	-	-	-
A	APPROVED FOR CONSTRUCTION	-	-	-	-

199 Bridge Street, Oakey, Qld, 4401

THIS DRAWING IS PRIVATE AND CONFIDENTIAL AND REMAINS THE PROPERTY OF FIELDQUIP. RETURNED UPON REQUEST. IT MUST NOT BE COPIED OR LOANED WITHOUT THE CONSENT OF FIELDQUIP.

SCALE	1:5	U.N.O
Design	D.M.	-
Drawn	MG	13.05.15
Check	AWP	13.05.15
Appd.	D.M.	13.05.15

GEARMOWER BLADE ASSEMBLY
GEARMOWER COMMON PARTS

3rd ANGLE PROJECTION U.N.O.	A3
Fieldquip Drawing Number	REV
GMC - 900	A

ITEM NO.	QTY.	PART No	DESCRIPTION	DRAWING No	WEIGHT kg	VENDOR	VENDOR No
1	1	HSM020	XTREME HEADSTOCK ARM RH	HSM - 20	12.13		
2	1	HSM021	XTREME HEADSTOCK ARM LH	HSM - 21	12.13		
3	2	HSM012	HEADSTOCK SPACER	HSM - 12	0.08		
4	1	HSM019	HEADSTOCK SPACER - SHORT	HSM - 19	0.06		
5	2	WF11N	1" FLAT WASHER	Purchased	0.04	TBA	TBA
6	3	LPB81	HEADSTOCK PIVOT PIN	Purchased	0.60	Bare Co	B81
7	3	LP10D	10mm LYNCH PIN	Purchased	0.05	Bare Co	B6
8	3	HHB5_8UNF-18T4½	5/8UNF x 4½" HEX BOLT	Purchased	0.22	MAPTCO	TBA
9	3	WF16M	M16 FLAT WASHER	Purchased	0.01	TBA	TBA
10	3	HNN5_8UNF	5/8" UNF HEX NYLOC NUT	Purchased	0.04	MAPTCO	TBA
11	2	HSM013	CHAIN BRACKET	HSM - 13	0.82		
12	2	DSHC13	13mm D-Shackle	Purchased	0.23	TBA	TBA

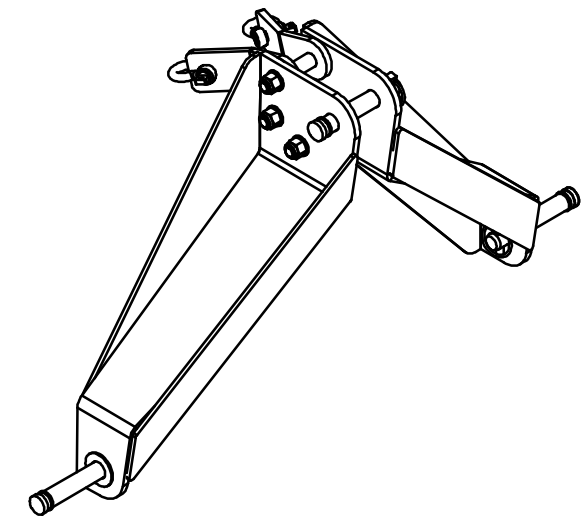
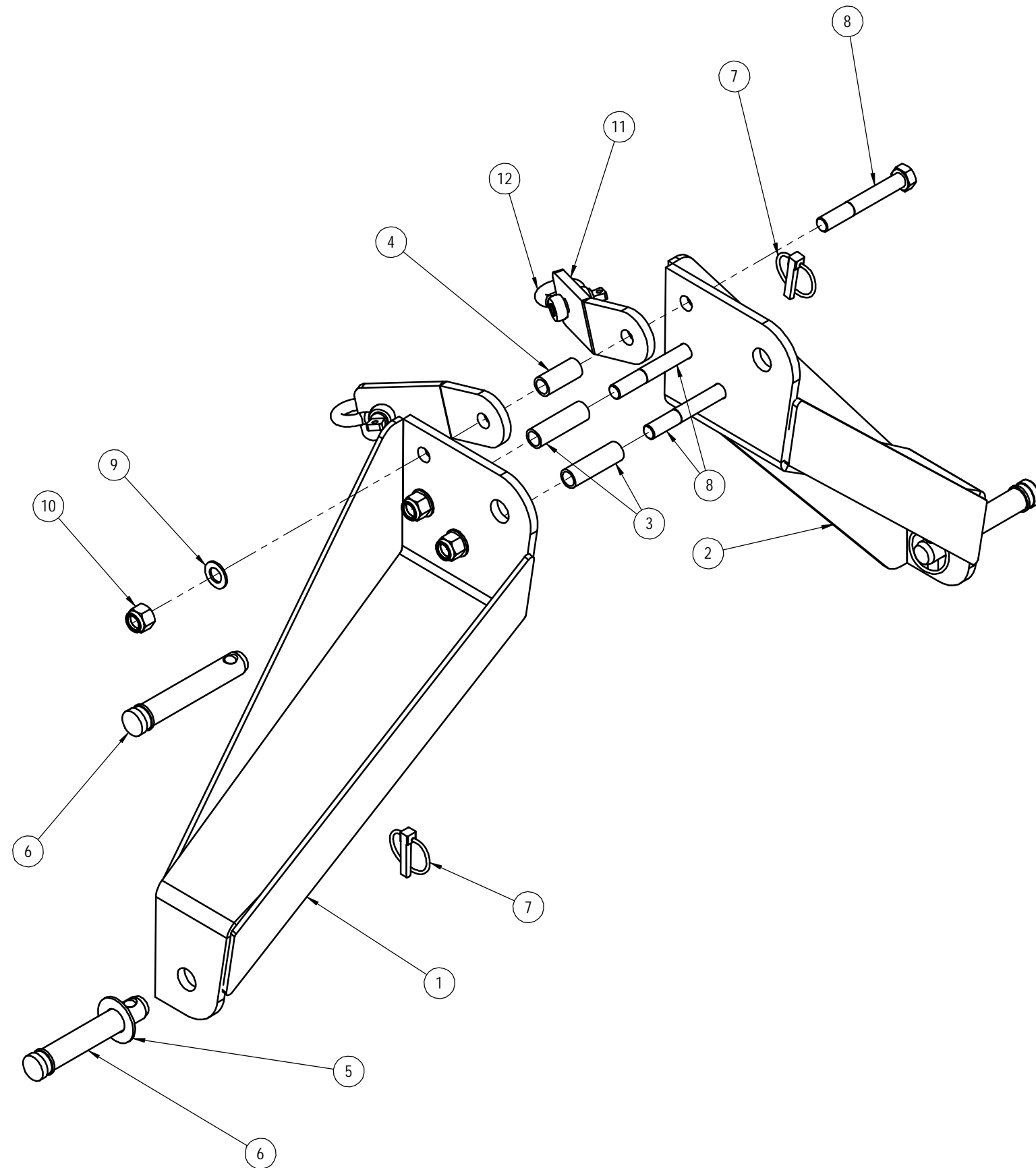

ISOMETRIC VIEW  
SCALE 1:10

DO NOT SCALE  
IF IN DOUBT - ASK WEIGHT 29385.0 GMS

Sheet 1 of 1

No.	Description	DWN	CHK	APPD	DATE
P1	PRELIMINARY DRAWING	-	-	-	-
A	APPROVED FOR CONSTRUCTION	-	-	-	-

199 Bridge Street, Oakey, Qld, 4401

**FIELDQUIP** *...smarter gear ...smarter care*  
Australian owned family business

THIS DRAWING IS PRIVATE AND CONFIDENTIAL AND REMAINS THE PROPERTY OF FIELDQUIP.  
RETURNED UPON REQUEST. IT MUST NOT BE COPIED OR LOANED WITHOUT THE CONSENT OF FIELDQUIP.

SCALE	1:5	U.N.O
Design	D.M.	-
Drawn	MG	13.05.15
Check	AWP	13.05.15
Appd.	D.M.	13.05.15

GEARMOWER HEADSTOCK	3rd ANGLE PROJECTION U.N.O.	A3
GEARMOWER COMMON PARTS	Fieldquip Drawing Number	REV
	GMC - 904	A



ITEM NO.	QTY.	PART No	DESCRIPTION	DRAWING No	WEIGHT kg	VENDOR	VENDOR No
1	1	GMC-500	CASTOR ARM	GMC - 500	16.67		
2	1	CSTW380	Ø380 CASTOR WHEEL	Purchased	41.05	TBA	TBA
3	3	LPB77	PIVOT PIN	Purchased	0.35	Bare Co	B 77
4	3	LP10D	10mm LYNCH PIN	Purchased	0.05	Bare Co	B6

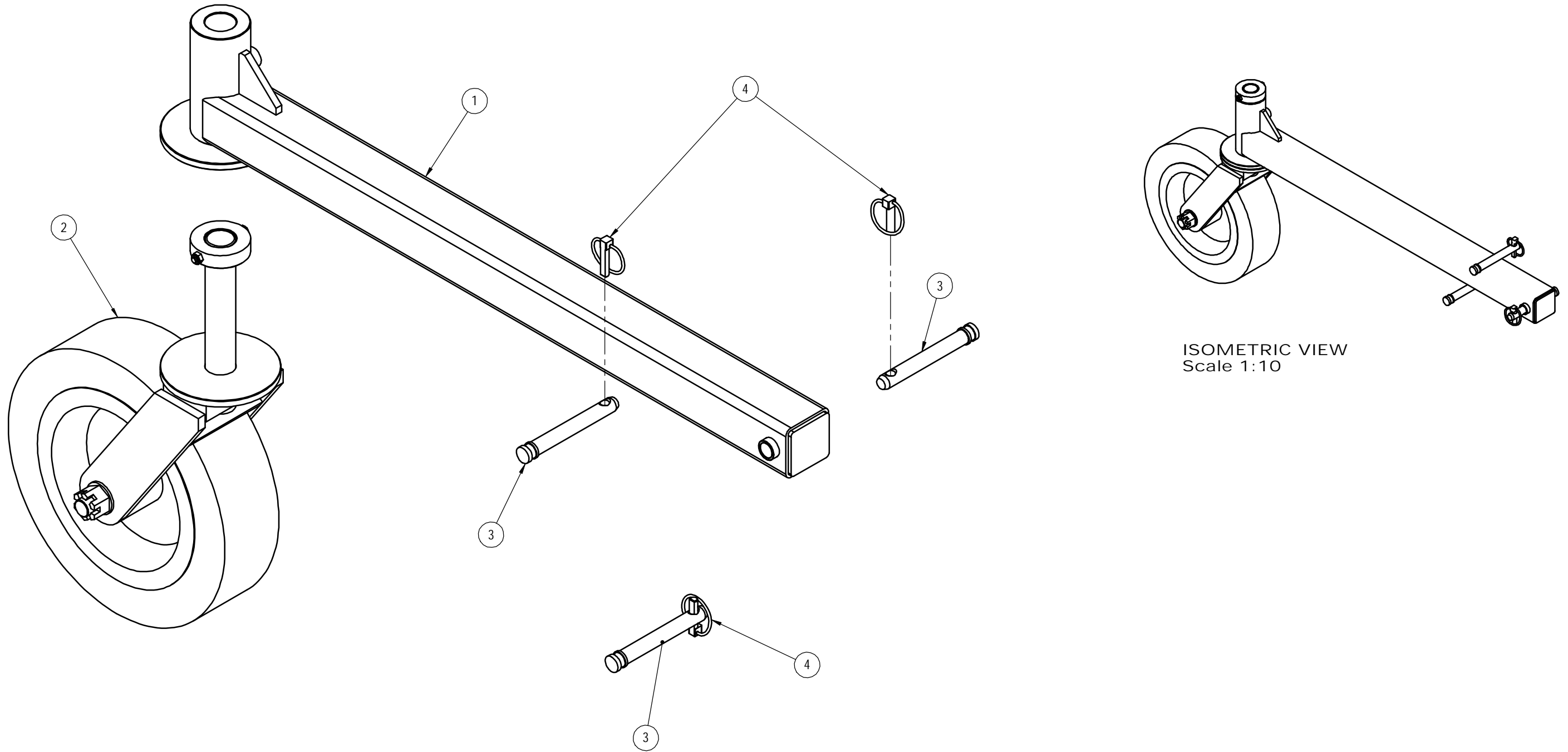

DO NOT SCALE  
IF IN DOUBT - ASK WEIGHT 58893.8 GMS

Sheet 1 of 1

No.	Description	DWN	CHK	APPD	DATE
P1	PRELIMINARY DRAWING	-	-	-	-
A	APPROVED FOR CONSTRUCTION	-	-	-	-

199 Bridge Street, Oakey, Qld, 4401

**FIELDQUIP** *...smarter gear ...smarter care*  
Australian owned family business

THIS DRAWING IS PRIVATE AND CONFIDENTIAL AND REMAINS THE PROPERTY OF FIELDQUIP.  
RETURNED UPON REQUEST. IT MUST NOT BE COPIED OR LOANED WITHOUT THE CONSENT OF FIELDQUIP.

SCALE	1:5	U.N.O
Design	D.M.	-
Drawn	MG	12.12.16
Check	AWP	15.12.16
Appd.	D.M.	15.12.16

GEARMOWER WHEEL & ARM	3rd ANGLE PROJECTION U.N.O.	A3
GEARMOWER COMMON PARTS	Fieldquip Drawing Number	REV
	GMC - 905	A