

ITEM NO.	QTY.	PART No	DESCRIPTION	DRAWING No	WEIGHT kg	VENDOR	VENDOR No
1	1	GM23-501	G.MOWER 230 90HP DECK FAB.	GM23 - 501	418.07		
2	1	GMC-904	GEARMOWER HEADSTOCK	GMC - 904	29.39		
3	2	LPB216	HEAVY DUTY PIN - 105	Purchased	0.70	Bare Co	B216
4	2	LP10D	10mm LYNCH PIN	Purchased	0.05	Bare Co	B6
5	2	GMC-905	GEARMOWER WHEEL & ARM	GMC - 905	58.89		
6	8	HHB3/4UNF-16T3	3/4" UNF x 3" HEX BOLT	Purchased	0.23	MAPTCO	TBA
7	8	HNN3/4UNF	3/4" UNF HEX NYLOC NUT	Purchased	0.06	MAPTCO	TBA
8	8	WF20MHT	M20 HIGH TENSILE FLAT WASHER	Purchased	0.02	TBA	TBA
9	4	GM23-020	GM 230 CHAIN GUARD	GM23 - 20	10.07		
10	16	HHB40M12	M12 x 40 HEX HEAD BOLT	Purchased	0.05	TBA	TBA
11	16	HNN12M	M12 NYLOC NUT	Purchased	0.02	TBA	TBA
12	16	WF12M	M12 FLAT WASHER	Purchased	0.01	TBA	TBA
13	2	DSHC13	13mm D-Shackle	Purchased	0.23	TBA	TBA
14	2	GMC-005	HEADSTOCK CHAIN	GMC - 05	4.66		
15	2	GMC-501	SKID - 850	GMC - 501	35.58		
16	8	HHB50M16	M16 x 50 HEX BOLT	Purchased	0.12	TBA	TBA
17	8	HNN16M	M16 HEX HEAD NUT	Purchased	0.04	TBA	TBA
18	8	WF16M	M16 FLAT WASHER	Purchased	0.01	TBA	TBA
19	8	SW16	M16 SP WASHER ZN PL	Purchased	0.00	TBA	TBA
20	90	LS80_23	CHAIN - GUARD	LS80 - 23	0.44		
21	2	GM23-018	GM 230 CHAIN RETAINER ROPE	GM23 - 18	0.60		
22	2	GMC-900	306mm GM BLADE CARRIER ASSY	GMC - 900	22.24		
23	4	DRV050	HEAVY DUTY COVER MOUNT	DRV - 50	1.52		
24	2	GM23-019	GM230 G.BOX SHAFT CVR 90HP	GM23 - 19	3.01		
25	16	HHB25M10	M10 x 40 HEX HEAD BOLT	Purchased	0.03	TBA	TBA
26	16	SW10	M10 SPRING WASHER ZN PL	Purchased	0.00	TBA	TBA
27	16	WF10M	M10 FLAT WASHER	Purchased	0.00	TBA	TBA
28	20	HHB5_16UNC-18T3/4	5/16UNC x 3/4 HEX BOLT	Purchased	0.01	MAPTCO	TBA
29	2	1070L	LH SLASHER BLADE 453mm	Purchased	3.21	PRATCO	SBH 413
30	2	1070R	RH SLASHER BLADE 453mm	Purchased	3.21	PRATCO	SBH414
31	1	GM23-601	DRIVE ASSEMBLY	GM23 - 601	184.66		
32	4	UCLP8mm	8mm U-CLAMP	Purchased	0.08	TBA	TBA
33	11	HNN8M	M8 NYLOC NUT	Purchased	0.01	TBA	TBA
34	1	ENC001	DOCUMENT HOLDER	Purchased	0.64	Bare Co	B1970
35	3	HHB25M8	M8 x 25 HEX BOLT	Purchased	0.02	TBA	TBA
36	3	WF8M	M8 FLAT WASHER	Purchased	0.00	TBA	TBA
37	4	SW12	M12 SPRING WASHER ZN PL	Purchased	0.01	TBA	TBA
38	4	HHB1/2UNC-13/4	1/2" UNC X 1 3/4 HEX HEAD BOLT	Purchased	0.05	TBA	TBA

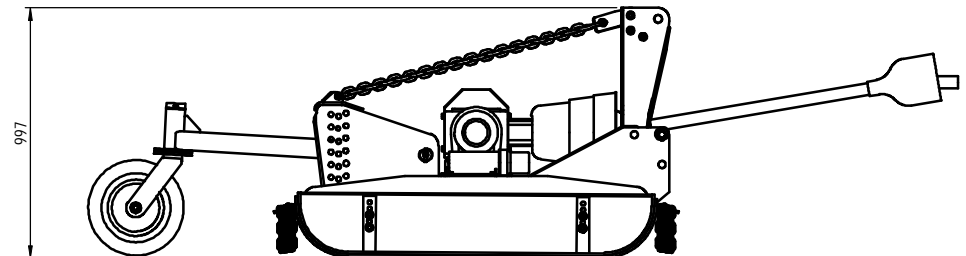
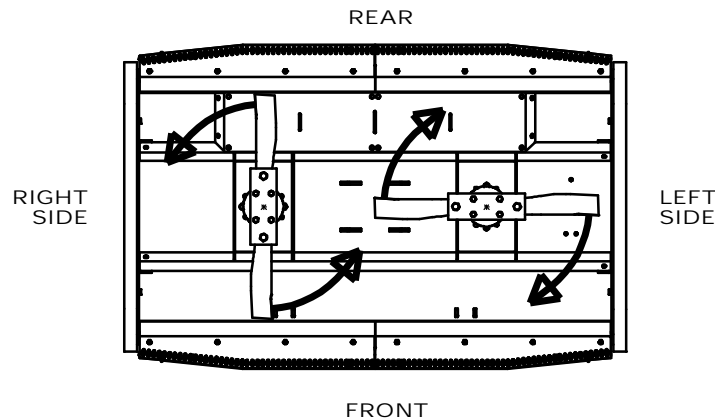
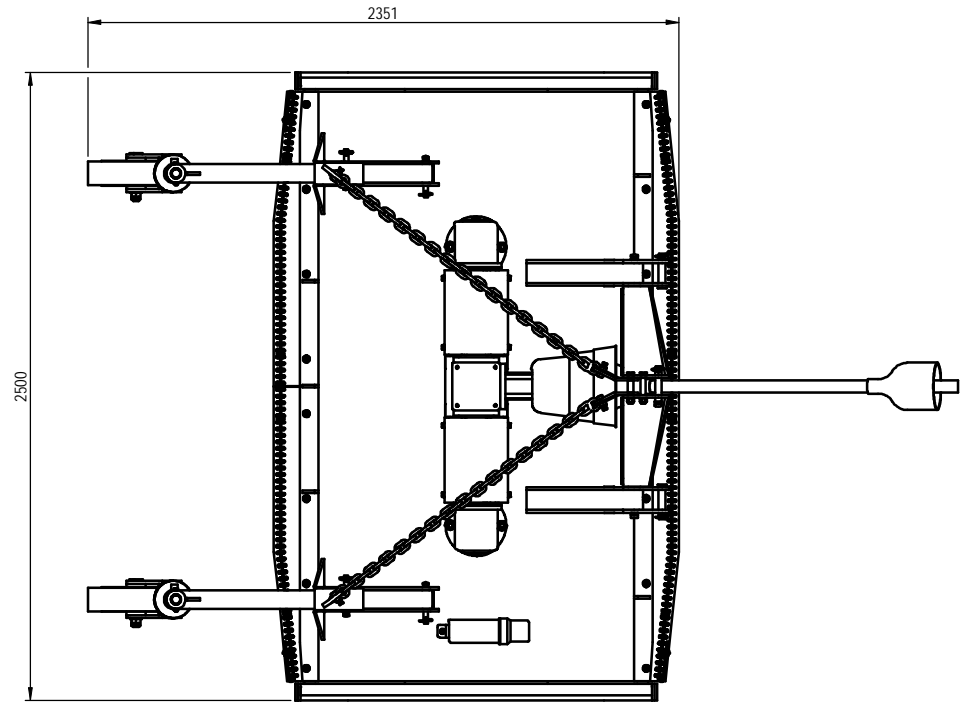

DO NOT SCALE
IF IN DOUBT - ASK WEIGHT 989966.9 GMS

No.	Description	DWN	CHK	APPD	DATE
P1	PRELIMINARY DRAWING	-	-	-	-
A	APPROVED FOR CONSTRUCTION	-	-	-	-
B	GENERAL REVISION AND TIDY UP	AWP	WP	WP	31.12.16

199 Bridge Street, Oakley, Qld, 4401

THIS DRAWING IS PRIVATE AND CONFIDENTIAL AND REMAINS THE PROPERTY OF FIELDQUIP. RETURNED UPON REQUEST. IT MUST NOT BE COPIED OR LOANED WITHOUT THE CONSENT OF FIELDQUIP.

SCALE	1:20	U.N.O
Design	D.M.	-
Drawn	MG	01.05.15
Check	AWP	01.05.15
Appd.	D.M.	01.05.15

90HP GEARMOWER 230 ASSY

90HP GEARMOWER 230 SERIES

Sheet 1 of 2	
3rd ANGLE PROJECTION U.N.O.	A3
Fieldquip Drawing Number	REV
GM23 - 901	B

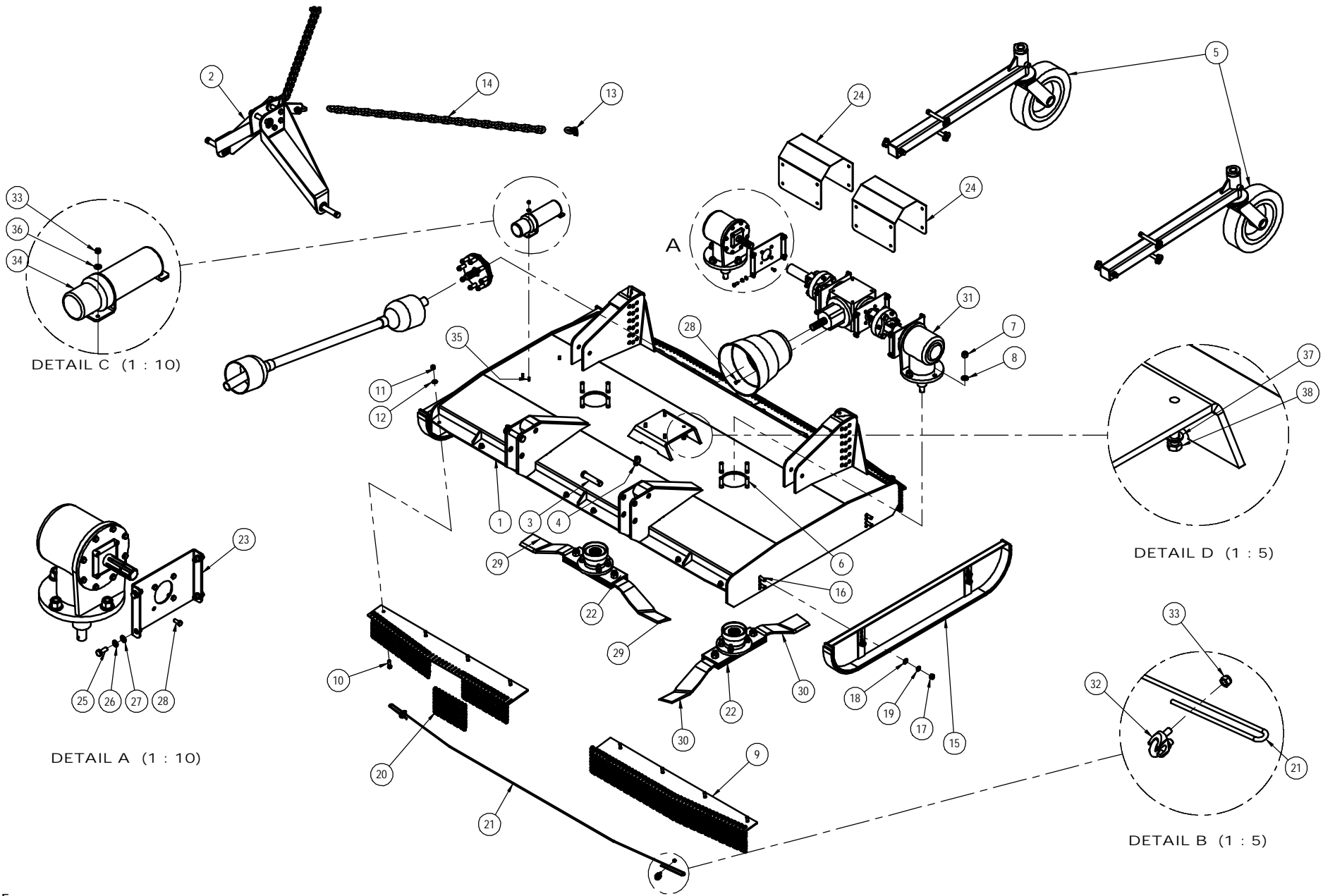

DO NOT SCALE
IF IN DOUBT - ASK WEIGHT 989966.9 GMS

199 Bridge Street, Oakley, Qld, 4401

Sheet 2 of 2

No.	Description	DWN	CHK	APPD	DATE
P1	PRELIMINARY DRAWING	-	-	-	-
A	APPROVED FOR CONSTRUCTION	-	-	-	-
B	GENERAL REVISION AND TIDY UP	AWP	WP	WP	31.12.16

THIS DRAWING IS PRIVATE AND CONFIDENTIAL AND REMAINS THE PROPERTY OF FIELDQUIP. RETURNED UPON REQUEST. IT MUST NOT BE COPIED OR LOANED WITHOUT THE CONSENT OF FIELDQUIP.

SCALE	1:20	U.N.O
Design	D.M.	-
Drawn	MG	01.05.15
Check	AWP	01.05.15
Appd.	D.M.	01.05.15

90HP GEARMOWER 230 ASSY
90HP GEARMOWER 230 SERIES

3rd ANGLE PROJECTION U.N.O.	A3
Fieldquip Drawing Number	REV
GM23 - 901	B

ITEM NO.	QTY.	PART No	DESCRIPTION	DRAWING No	WEIGHT kg	VENDOR	VENDOR No
1	1	GC - 27-23-20-18	DRIVE KIT (Bare Co - TBA)	GC - 27-23-20-18	135.36	Bare Co	TBA
2	2	GM27-502	90HP CONNECT COUPLING ASSY	GM27 - 502			
3	1	COV001	10" COVER	Purchased	0.99	Bare Co	AS8409
4	1	FQB7240	100HP BLUE TORQUE SAFETY CLUTCH	Purchased	6.41	Bare Co	B7240
5	1	PTO002	63" 20 SPLINE PTO SHAFT - 8 SERIES	Purchased	15.51	Bare Co	DB8105

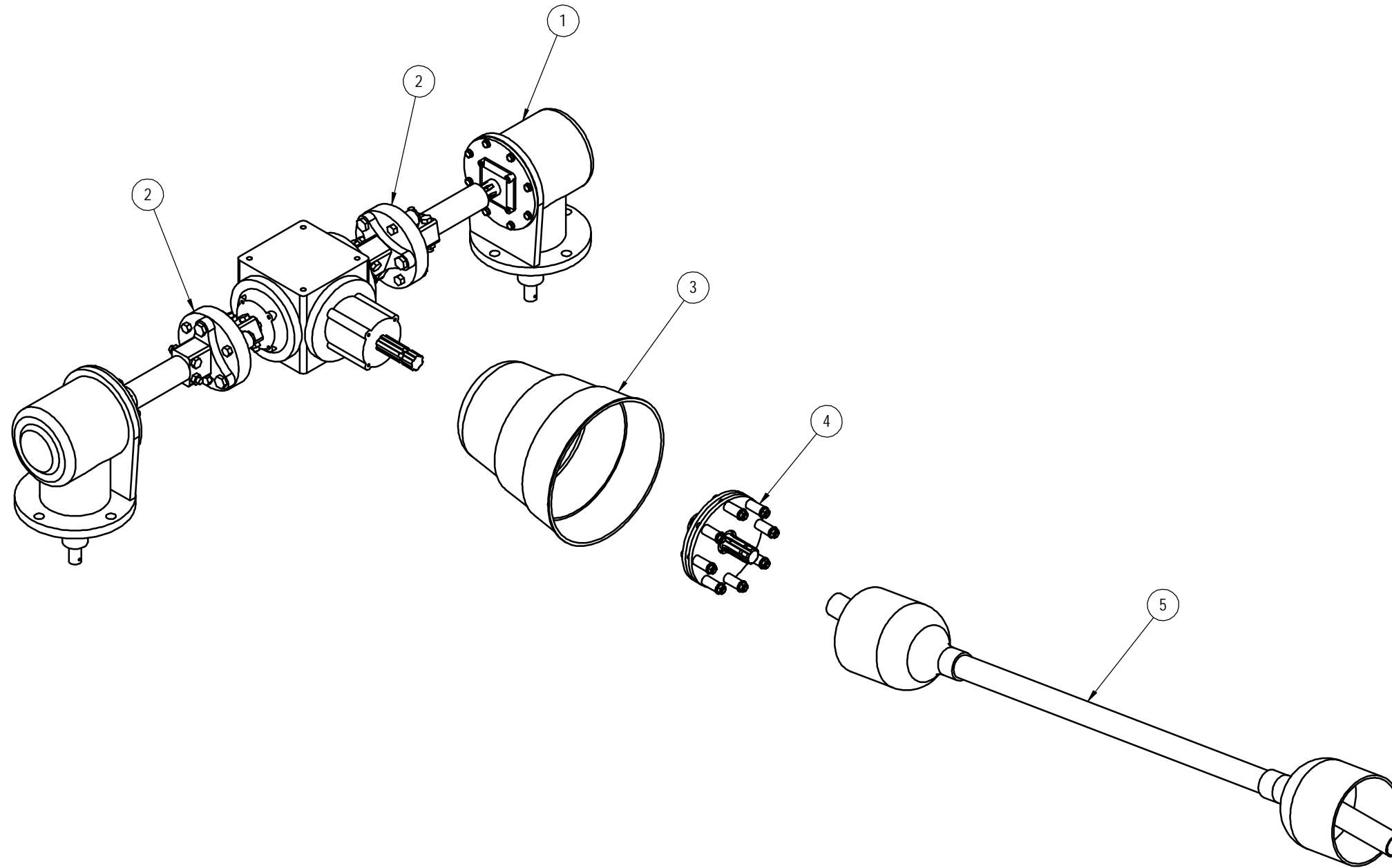

DO NOT SCALE
IF IN DOUBT - ASK WEIGHT 184662.5 GMS

Sheet 1 of 1

No.	Description	DWN	CHK	APPD	DATE
P1	PRELIMINARY DRAWING	-	-	-	-
A	APPROVED FOR CONSTRUCTION	-	-	-	-

199 Bridge Street, Oakey, Qld, 4401



THIS DRAWING IS PRIVATE AND CONFIDENTIAL AND REMAINS THE PROPERTY OF FIELDQUIP.
RETURNED UPON REQUEST. IT MUST NOT BE COPIED OR LOANED WITHOUT THE CONSENT OF FIELDQUIP.

SCALE	1:10	U.N.O
Design	D.M.	-
Drawn	AWP	31.12.16
Check	WP	23.01.17
Appd.	AWP	23.01.17

DRIVE ASSEMBLY

GEARMOWER 230 SERIES

3rd ANGLE PROJECTION U.N.O.	A3
Fieldquip Drawing Number	REV
GM23 - 601	A

ITEM NO.	QTY.	PART NUMBER	DRAWING NUMBER	WEIGHT IN kg	DESCRIPTION
1	1	GM23-017	GM23 - 17	148.7	GM230 90HP CUTTER DECK
2	4	GMC-023	GMC - 23	9.1	OUTER LIFT PLATE
3	2	HSM015	HSM - 15	2.8	LIFT PLATE GUSSET
4	2	GMC-022	GMC - 22	10.6	CASTOR WHEEL BRACKET - LH
5	2	GMC-021	GMC - 21	10.6	CASTOR WHEEL BRACKET - RH
6	2	GMC-012	GMC - 12	1.4	CHAIN MOUNT PLATE
7	2	GMC-013	GMC - 13	26.2	DECK SIDE STIFFENER PLATE
8	2	GM23-005	GM23 - 05	12.9	GM 230 CHAIN GUARD SUPPORT
9	4	GM23-006	GM23 - 06	9.6	CHAIN GUARD MOUNT PLATE
10	2	GMC-001	GMC - 01	9.1	DECK GEARBOX STIFFENER
11	2	GM23-008	GM23 - 08	10.7	UNDER DECK SUPPORT
12	2	GMC-010	GMC - 10	0.3	CHAIN ANCHOR POINT
13	3	GMC-017	GMC - 17	1.2	UNDER DECK SPACER
14	1	GMC-008	GMC - 08	7.0	GRASS DEFLECTOR
15	2	GMC-018	GMC - 18	0.5	GRASS PLATE SUPPORT
16	4	GMC-019	GMC - 19	0.8	SKID PLATE GUSSET
17	8	XTR90-006	XTR90 - 06	0.2	GUARD SUPPORT GUSSET - 7°
18	1	GMC-020	GMC - 20	9.9	GEARBOX MOUNT PLATE

ALL WELDS 6 CFW UNO

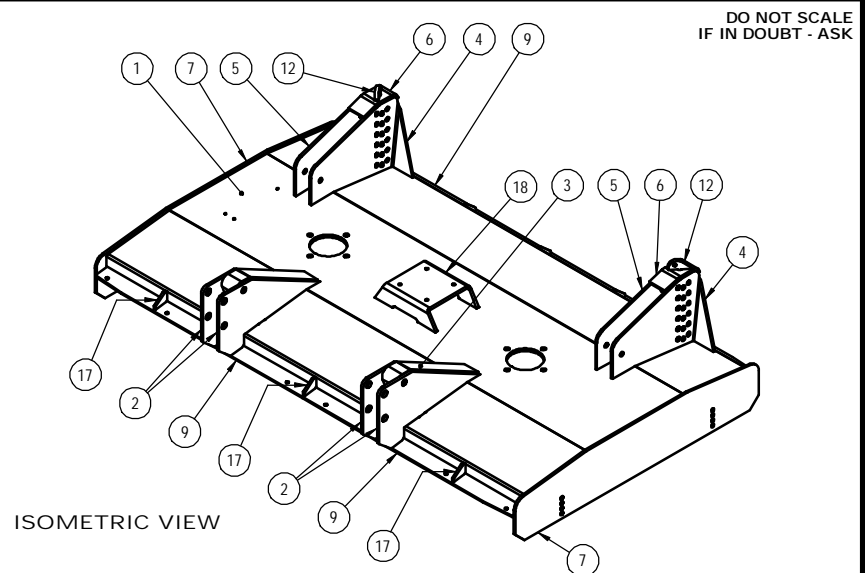
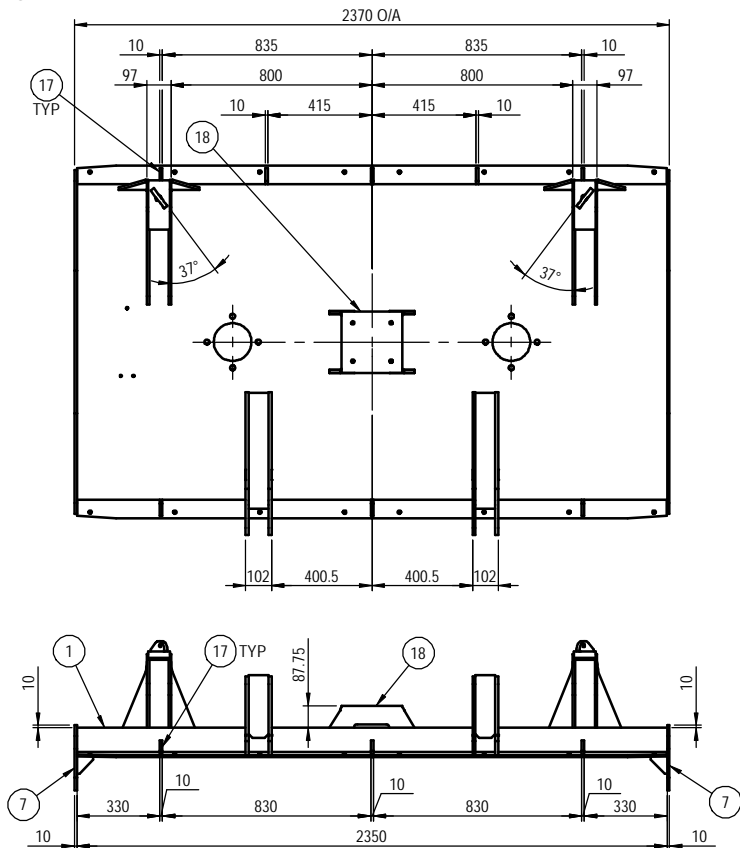

DO NOT SCALE
IF IN DOUBT - ASK

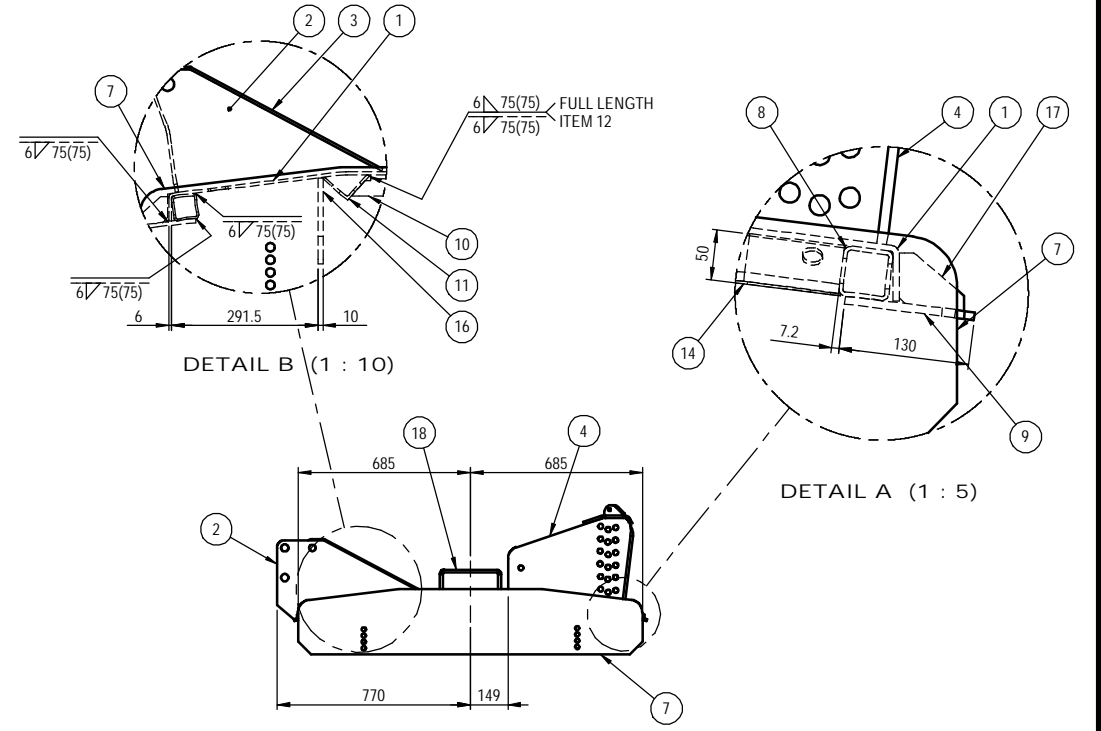

WEIGHT 418071.9 GMS

199 Bridge Street, Oakley, Qls, 4401

Sheet 1 of 2

No.	Description	DWN	CHK	APPD	DATE
PT	PRELIMINARY DRAWING	-	-	-	-
A	APPROVED FOR CONSTRUCTION	-	-	-	-
B	RE-DRAWN WITH MODS AND CORRECTIONS	AWP	WP	WP	31.12.16

FIELDQUIP
Australian owned family business

THIS DRAWING IS PRIVATE AND CONFIDENTIAL AND REMAINS THE PROPERTY OF FIELDQUIP.
RETURNED UPON REQUEST. IT MUST NOT BE COPIED OR LOANED WITHOUT THE CONSENT OF FIELDQUIP.

SCALE	1:20	U.N.O
Design	D.M.	-
Drawn	MG	04.06.15
Check	AWP	04.06.15
Appd.	D.M.	04.06.15

G.MOWER 230 90HP DECK FAB.
90HP GEARMOWER 230 SERIES

3rd ANGLE PROJECTION U.N.O.	A.3
Fieldquip Drawing Number	REV
GM23 - 501	B

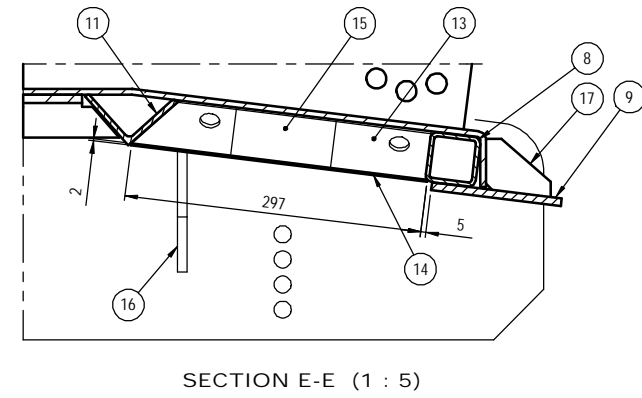
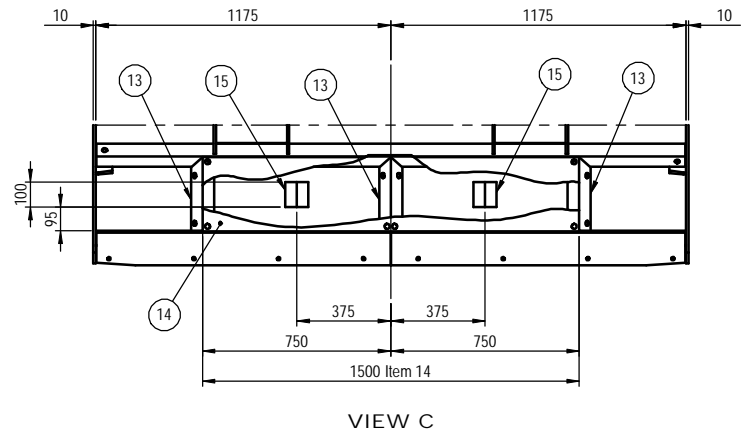
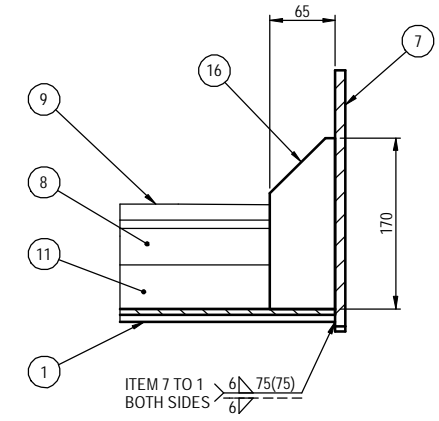
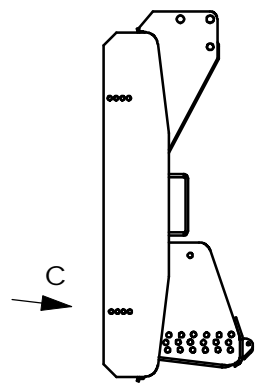
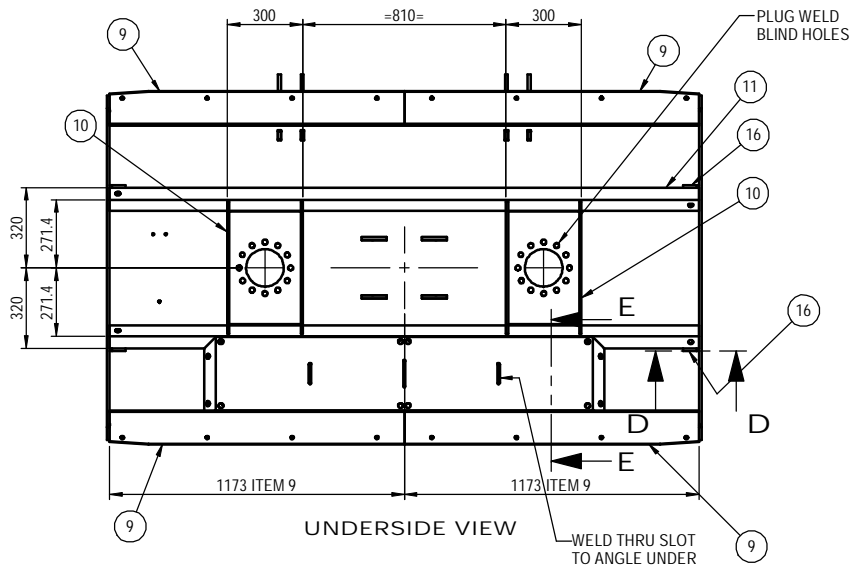

DO NOT SCALE
IF IN DOUBT - ASK WEIGHT 418071.9 GMS

199 Bridge Street, Oakey, Qld, 4401

Sheet 2 of 2

No.	Description	DWN	CHK	APPD	DATE
P1	PRELIMINARY DRAWING	-	-	-	-
A	APPROVED FOR CONSTRUCTION	-	-	-	-
B	RE-DRAWN WITH MODS AND CORRECTIONS	AWP	WP	WP	31.12.16

THIS DRAWING IS PRIVATE AND CONFIDENTIAL AND REMAINS THE PROPERTY OF FIELDQUIP. RETURNED UPON REQUEST. IT MUST NOT BE COPIED OR LOANED WITHOUT THE CONSENT OF FIELDQUIP.

SCALE 1:20 U.N.O
 Design D.M. -
 Drawn MG 04.06.15
 Check AWP 04.06.15
 Appd. D.M. 04.06.15

G.MOWER 230 90HP DECK FAB.

90HP GEARMOWER 230 SERIES

3rd ANGLE PROJECTION U.N.O.	A3
Fieldquip Drawing Number	REV
GM23 - 501	B

ITEM NO.	QTY.	PART No	DESCRIPTION	DRAWING No	WEIGHT kg	VENDOR	VENDOR No
1	1	GMC-500	CASTOR ARM	GMC - 500	16.67		
2	1	CSTW380	Ø380 CASTOR WHEEL	Purchased	41.05	TBA	TBA
3	3	LPB77	PIVOT PIN	Purchased	0.35	Bare Co	B 77
4	3	LP10D	10mm LYNCH PIN	Purchased	0.05	Bare Co	B6

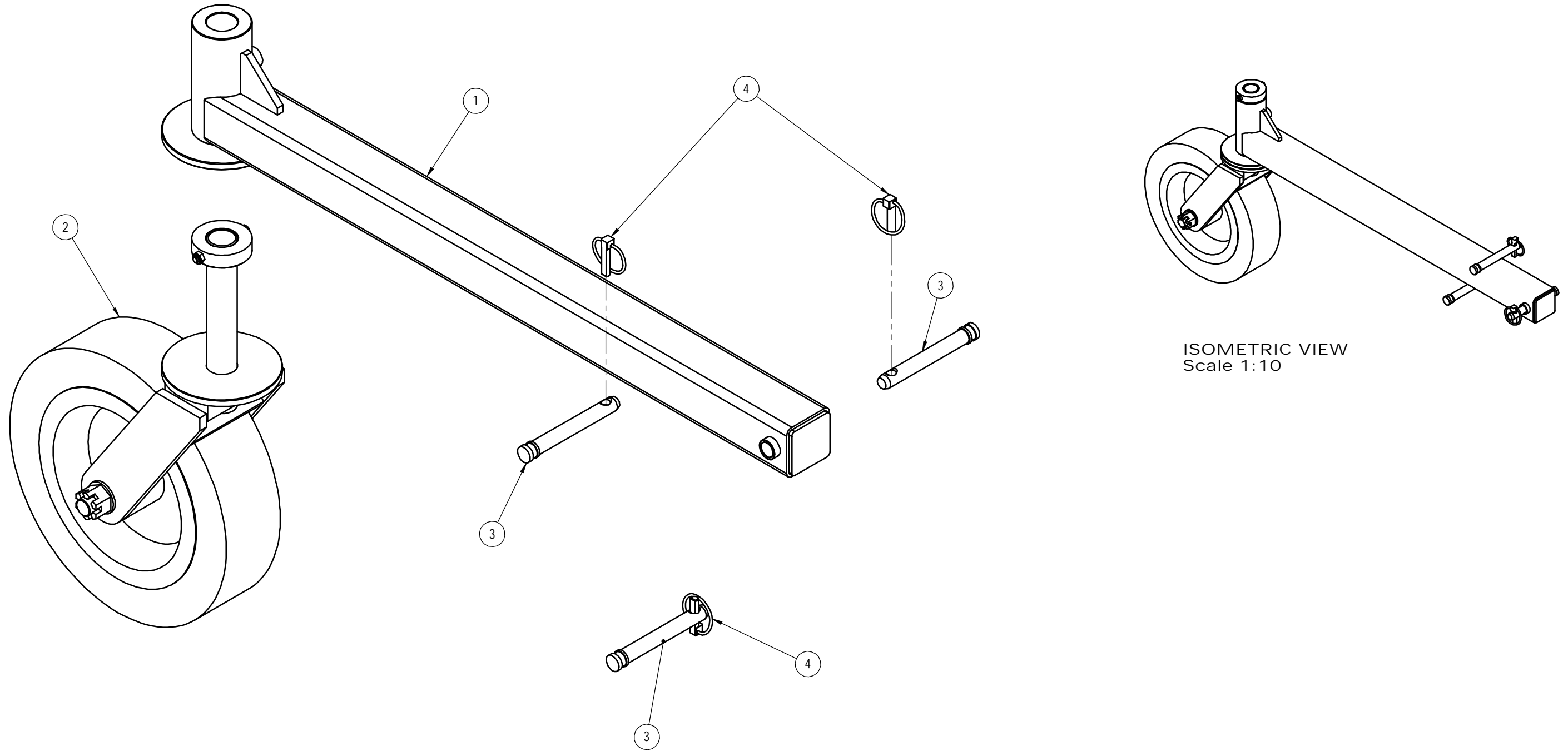

ISOMETRIC VIEW
Scale 1:10

DO NOT SCALE
IF IN DOUBT - ASK WEIGHT 58893.8 GMS

Sheet 1 of 1

No.	Description	DWN	CHK	APPD	DATE
P1	PRELIMINARY DRAWING	-	-	-	-
A	APPROVED FOR CONSTRUCTION	-	-	-	-

199 Bridge Street, Oakey, Qld, 4401



FIELDQUIP

...smarter gear
...smarter care

Australian owned family business

THIS DRAWING IS PRIVATE AND CONFIDENTIAL AND REMAINS THE PROPERTY OF FIELDQUIP.
RETURNED UPON REQUEST. IT MUST NOT BE COPIED OR LOANED WITHOUT THE CONSENT OF FIELDQUIP.

SCALE	1:5	U.N.O
Design	D.M.	-
Drawn	MG	12.12.16
Check	AWP	15.12.16
Appd.	D.M.	15.12.16

GEARMOWER WHEEL & ARM	
GEARMOWER COMMON PARTS	

3rd ANGLE PROJECTION U.N.O.	A3
Fieldquip Drawing Number	REV
GMC - 905	A

ITEM NO.	QTY.	PART No	DESCRIPTION	DRAWING No	WEIGHT kg	VENDOR	VENDOR No
1	1	HSM020	XTREME HEADSTOCK ARM RH	HSM - 20	12.13		
2	1	HSM021	XTREME HEADSTOCK ARM LH	HSM - 21	12.13		
3	2	HSM012	HEADSTOCK SPACER	HSM - 12	0.08		
4	1	HSM019	HEADSTOCK SPACER - SHORT	HSM - 19	0.06		
5	2	WF11N	1" FLAT WASHER	Purchased	0.04	TBA	TBA
6	3	LPB81	HEADSTOCK PIVOT PIN	Purchased	0.60	Bare Co	B81
7	3	LP10D	10mm LYNCH PIN	Purchased	0.05	Bare Co	B6
8	3	HHB5_8UNF-18T4½	5/8UNF x 4½" HEX BOLT	Purchased	0.22	MAPTCO	TBA
9	3	WF16M	M16 FLAT WASHER	Purchased	0.01	TBA	TBA
10	3	HNN5_8UNF	5/8" UNF HEX NYLOC NUT	Purchased	0.04	MAPTCO	TBA
11	2	HSM013	CHAIN BRACKET	HSM - 13	0.82		
12	2	DSHC13	13mm D-Shackle	Purchased	0.23	TBA	TBA

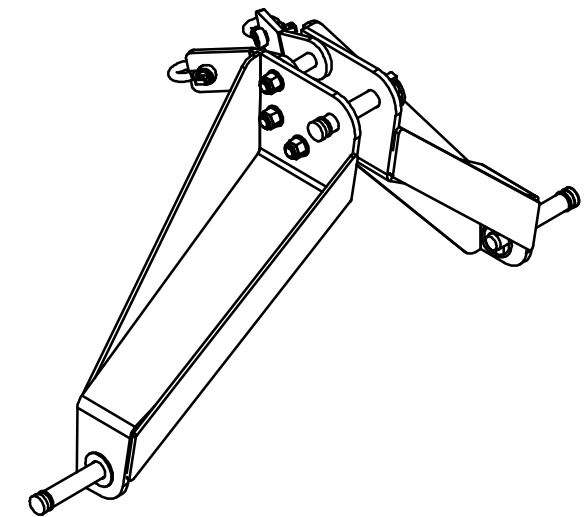
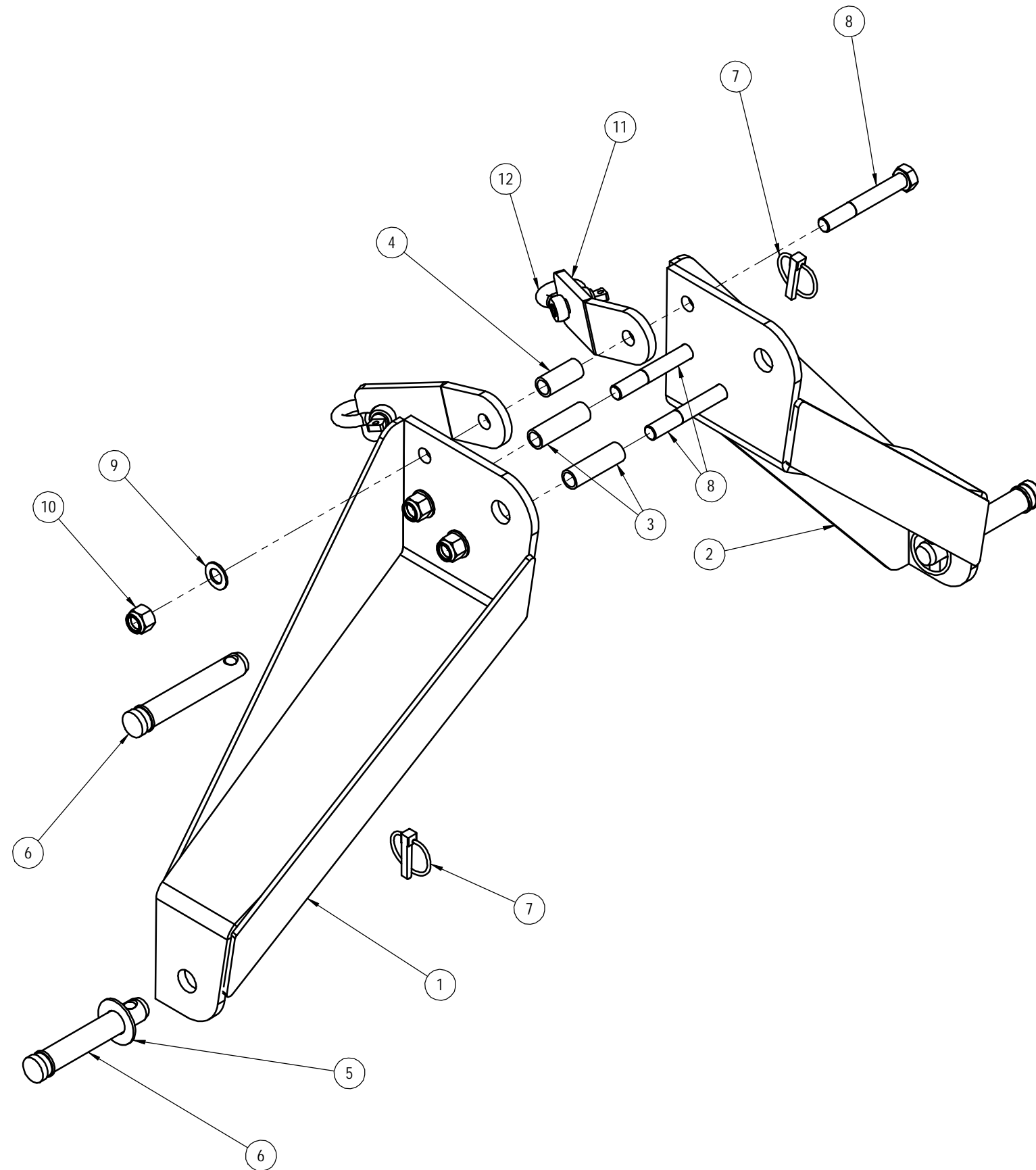

ISOMETRIC VIEW
SCALE 1:10

DO NOT SCALE
IF IN DOUBT - ASK WEIGHT 29385.0 GMS

Sheet 1 of 1

No.	Description	DWN	CHK	APPD	DATE
P1	PRELIMINARY DRAWING	-	-	-	-
A	APPROVED FOR CONSTRUCTION	-	-	-	-

199 Bridge Street, Oakey, Qld, 4401



FIELDQUIP

...smarter gear
...smarter care
Australian owned family business

THIS DRAWING IS PRIVATE AND CONFIDENTIAL AND REMAINS THE PROPERTY OF FIELDQUIP.
RETURNED UPON REQUEST. IT MUST NOT BE COPIED OR LOANED WITHOUT THE CONSENT OF FIELDQUIP.

SCALE	1:5	U.N.O
Design	D.M.	-
Drawn	MG	13.05.15
Check	AWP	13.05.15
Appd.	D.M.	13.05.15

GEARMOWER HEADSTOCK	
GEARMOWER COMMON PARTS	

3rd ANGLE PROJECTION U.N.O.	A3
Fieldquip Drawing Number	REV
GMC - 904	A

ITEM NO.	QTY.	PART No	DESCRIPTION	DRAWING No	WEIGHT kg	VENDOR	VENDOR No
1	1	XTR100	BLADE HUB ASSY - 200HP	XTR - 100	9.29		
2	1	GMC-418	BLADE BEAM SPACER	GMC - 418	2.15		
3	2	SBH419	BEAM 130x12x380	Purchased	4.50	Pratco	SBH 419
4	2	BSH322211	BLADE BUSH	BSH-322211	0.03		
5	4	HHB5_8UNF-18T3½	5/8UNF x 4.5" HEX BOLT	Purchased	0.18	MAPTCO	TBA
6	2	HHB7_8UNF-14T2¾	7/8" UNF x 2¾" HEX BOLT	Purchased	0.31	MAPTCO	TBA
7	2	HNN7_8UNF	7/8" UNF HEX NYLOC NUT	Purchased	0.11	MAPTCO	TBA
8	4	HNN5_8UNF	5/8" UNF HEX NYLOC NUT	Purchased	0.04	MAPTCO	TBA

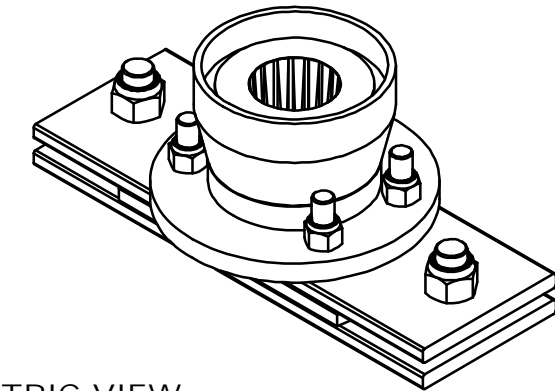
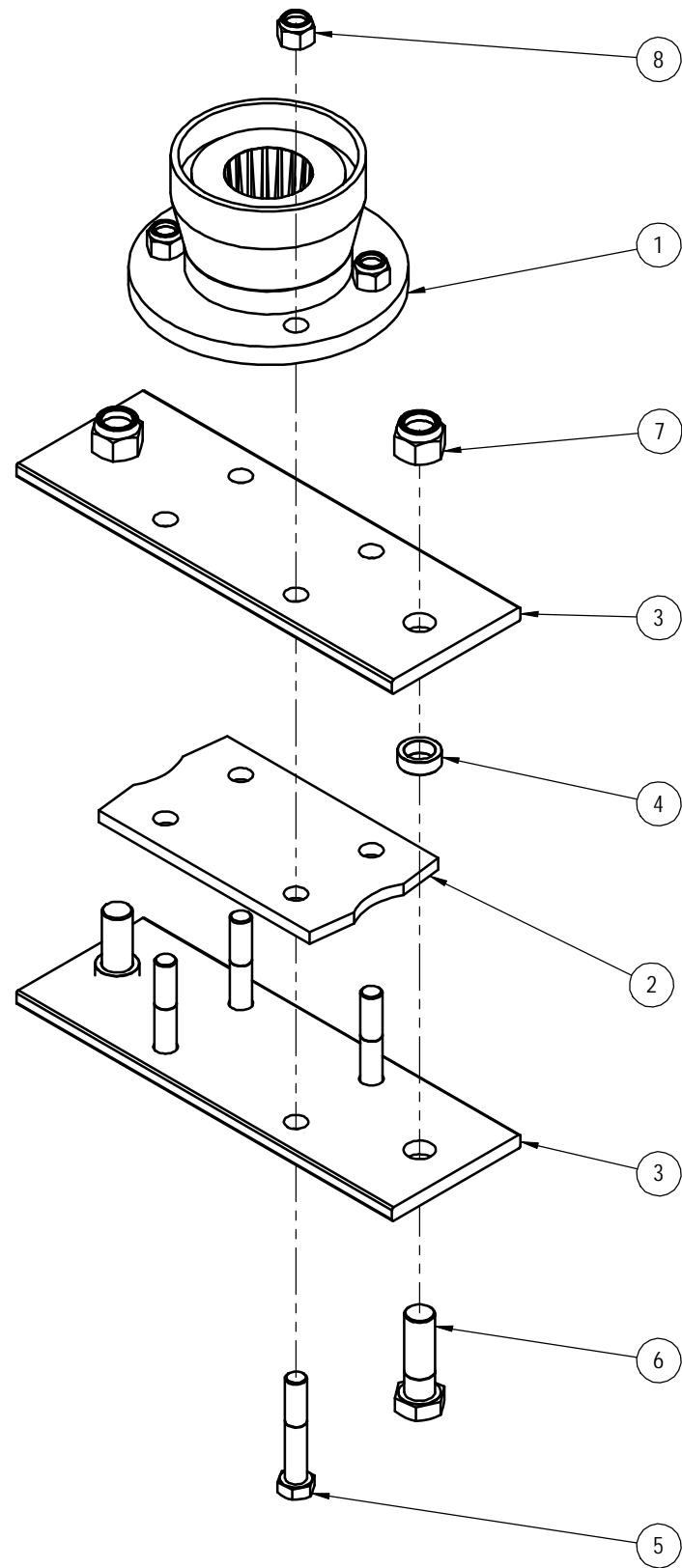

ISOMETRIC VIEW

DO NOT SCALE
IF IN DOUBT - ASK WEIGHT 22235.1 GMS

Sheet 1 of 1

No.	Description	DWN	CHK	APPD	DATE
P1	PRELIMINARY DRAWING	-	-	-	-
A	APPROVED FOR CONSTRUCTION	-	-	-	-

199 Bridge Street, Oakey, Qld, 4401

FIELDQUIP
...smarter gear
...smarter care
AUSTRALIAN OWNED FAMILY BUSINESS

THIS DRAWING IS PRIVATE AND CONFIDENTIAL AND REMAINS THE PROPERTY OF FIELDQUIP.
RETURNED UPON REQUEST. IT MUST NOT BE COPIED OR LOANED WITHOUT THE CONSENT OF FIELDQUIP.

SCALE	1:5	U.N.O
Design	D.M.	-
Drawn	MG	13.05.15
Check	AWP	13.05.15
Appd.	D.M.	13.05.15

GEARMOWER BLADE ASSEMBLY	
GEARMOWER COMMON PARTS	

3rd ANGLE PROJECTION U.N.O.	
Fieldquip Drawing Number	REV
GMC - 900	A

ITEM NO.	QTY.	PART NUMBER	DRAWING NUMBER	WEIGHT IN kg	DESCRIPTION
1	1	GMC-006	GMC - 06	17.0	SKID BODY
2	2	GMC-007	GMC - 07	8.8	SKID PLATE
3	2	06165-5_11	06165-5 - 11	0.5	SKID ADJUSTER PLATE

NOTE: ALL WELDS 5 CFW UNO

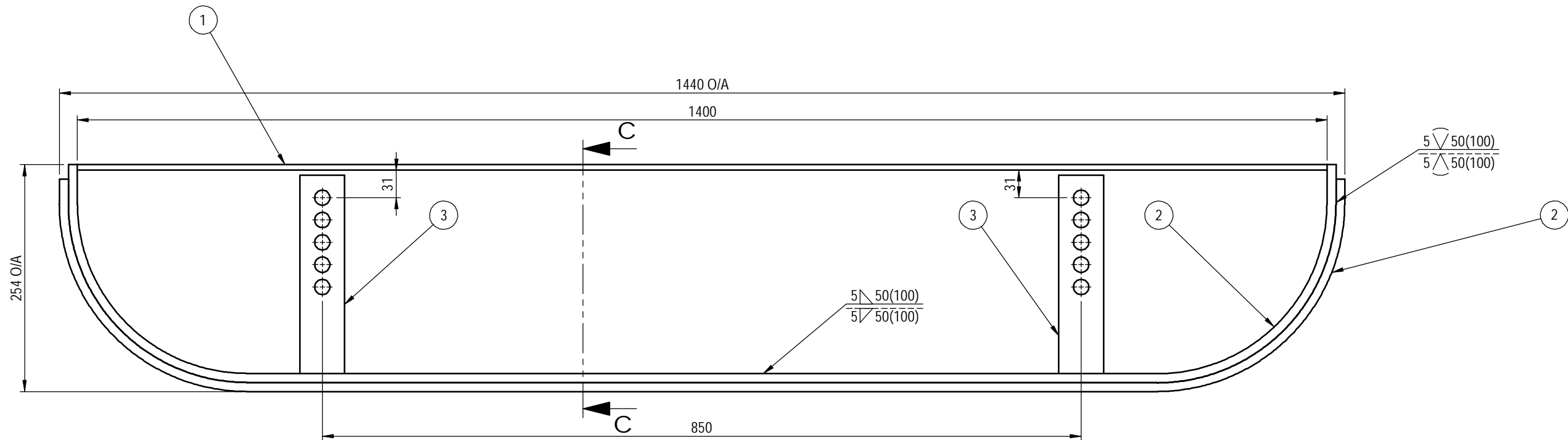
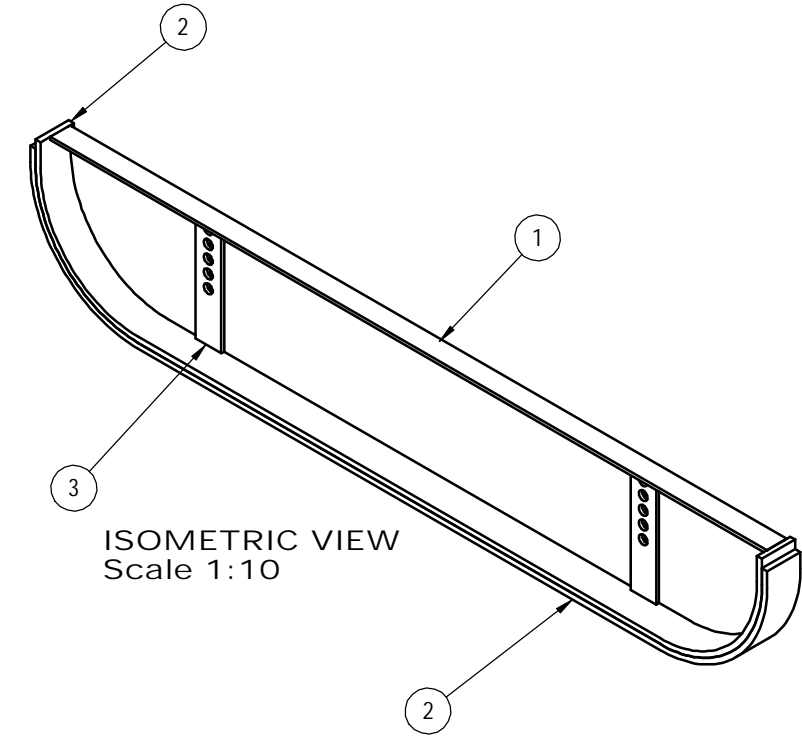
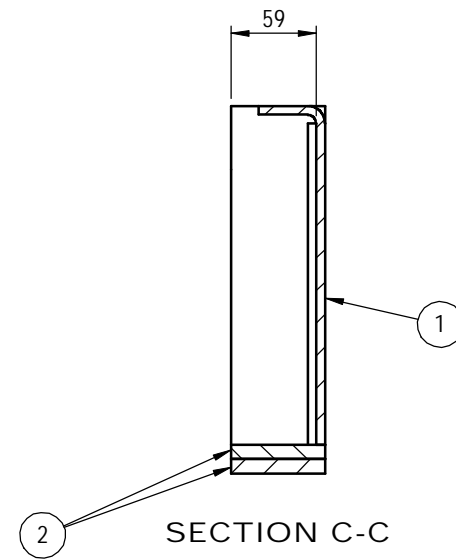

DO NOT SCALE
IF IN DOUBT - ASK WEIGHT 35576.1 GMS

Sheet 1 of 1

No.	Description	DWN	CHK	APPD	DATE
P1	PRELIMINARY DRAWING	-	-	-	-
A	APPROVED FOR CONSTRUCTION	-	-	-	-

199 Bridge Street, Oakey, Qld, 4401

THIS DRAWING IS PRIVATE AND CONFIDENTIAL AND REMAINS THE PROPERTY OF FIELDQUIP.
RETURNED UPON REQUEST. IT MUST NOT BE COPIED OR LOANED WITHOUT THE CONSENT OF FIELDQUIP.

SCALE	1:5	U.N.O
Design	D.M.	
Drawn	MG	06.05.15
Check	AWP	06.05.15
Appd.	D.M.	06.05.15

SKID - 850

GEARMOWER COMMON PARTS

3rd ANGLE PROJECTION U.N.O.		A3
Fieldquip Drawing Number		REV
GMC - 501		A